



**Программа Организации
Объединенных Наций по
окружающей среде**



Distr.
GENERAL

UNEP/OzL.Pro/ExCom/76/56
14 April 2016

RUSSIAN
ORIGINAL: ENGLISH

ИСПОЛНИТЕЛЬНЫЙ КОМИТЕТ
МНОГОСТОРОННЕГО ФОНДА ДЛЯ
ОСУЩЕСТВЛЕНИЯ МОНРЕАЛЬСКОГО ПРОТОКОЛА
Семьдесят шестое совещание
Монреаль, 9 - 13 мая 2016 года

ПРОЕКТНЫЕ ПРЕДЛОЖЕНИЯ: ГЛОБАЛЬНЫЕ

Настоящий документ включает комментарии и рекомендации секретариата Фонда по следующим проектным предложениям:

Технология охлаждения

- Демонстрационный проект для внедрения сверхкритической технологии охлаждения на базе CO₂ для супермаркетов (Аргентина и Тунис) ЮНИДО
- Демонстрационный проект по качеству хладагента, мерам сдерживания и внедрению альтернативных хладагентов с низким потенциалом глобального потепления (ПГП) ЮНИДО / ЮНЕП

ОЦЕНОЧНЫЙ ЛИСТ ПРОЕКТА - НЕ МНОГОЛЕТНИЙ ПРОЕКТ

**Глобальный
НАИМЕНОВАНИЕ ПРОЕКТА ДВУСТОРОННИЙ / УЧРЕЖДЕНИЕ-ИСПОЛНИТЕЛЬ**

а) Демонстрационный проект для внедрения сверхкритической технологии охлаждения на базе CO ₂ для супермаркетов (Аргентина и Тунис)	ЮНИДО
---	-------

НАЦИОНАЛЬНОЕ КООРДИНИРУЮЩЕЕ УЧРЕЖДЕНИЕ	не прим.
---	----------

**ПОСЛЕДНИЕ ПРЕДСТАВЛЕННЫЕ ДАННЫЕ О ПОТРЕБЛЕНИИ ОРВ, УКАЗАННЫХ В ПРОЕКТЕ
А: ДАННЫЕ ПО СТАТЬЕ 7 (В ТОННАХ ОРП, 2014 Г., ПО СОСТОЯНИЮ НА МАРТ 2016 Г.)**

ГХФУ	не прим.
------	----------

В: ДАННЫЕ СТРАНОВОЙ ПРОГРАММЫ ПО СЕКТОРАМ (В ТОННАХ ОРП, 2014 Г., ПО СОСТОЯНИЮ НА МАРТ 2016 Г.)

ГХФУ - 22	не прим.
ГХФУ - 123	не прим.
ГХФУ - 141b	не прим.
ГХФУ - 142b	не прим.
ГХФУ - 141b в импортируемых смесях полиола	не прим.

Потребление ГХФУ, все еще подпадающее под финансирование (в тоннах ОРП)	не прим.
--	----------

АССИГНОВАНИЯ ПО БИЗНЕС-ПЛАНУ ЗА ТЕКУЩИЙ ГОД	а)	Финансирование в долл. США	Поэтапный отказ в тоннах ОРП
		не прим.	не прим.
НАИМЕНОВАНИЕ ПРОЕКТА:			
Использование ОРВ на предприятии (в тоннах ОРП)			не прим.
ОРВ, подлежащие поэтапному отказу (в тоннах ОРП)			не прим.
ОРВ, подлежащие поэтапному внедрению (в тоннах ОРП)			не прим.
Продолжительность проекта (в месяцах)			30
Первоначальная запрашиваемая сумма (долл. США)			968 665
Аргентина			601 620
Тунис			367 045
Окончательные затраты на проект (долл. США)			846 300
Дополнительные капитальные затраты			не прим.
Непредвиденные расходы (10%)			не прим.
Дополнительные эксплуатационные расходы			не прим.
Общая стоимость проекта			846 300
Аргентина			527 169
Тунис			319 131
Местное доленое участие (%)			не прим.
Экспортный компонент (%)			не прим.
Запрашиваемый грант (долл. США)			846 300
Эффективность затрат (долл. США/кг)			не прим.
Вспомогательные расходы учреждения-исполнителя (долл. США)			59 241
Общая стоимость проекта для Многостороннего фонда (долл. США)			905 541
Статус финансирования контрагента (Да / Нет)			Нет
Включены этапы мониторинга проекта (Да / Нет)			Да

РЕКОМЕНДАЦИЯ СЕКРЕТАРИАТА	Индивидуальное рассмотрение
----------------------------------	-----------------------------

ОПИСАНИЕ ПРОЕКТА

Базовая информация

1. От имени правительств Аргентины и Туниса ЮНИДО, назначенная в качестве учреждения-исполнителя, представляет на рассмотрение 76-го совещания просьбу о финансировании глобального демонстрационного проекта по внедрению сверхкритической технологии охлаждения на базе CO₂ (R-744) для супермаркетов на сумму 968 665 долл. США плюс вспомогательные расходы в размере 67 806 долл. США, в соответствии с первоначально представленными данными¹. Проектное предложение содержится в Приложении I к настоящему документу.

Цель проекта

2. Основными препятствиями для внедрения альтернативных хладагентов с низким потенциалом глобального потепления (ПГП), особенно CO₂, в секторе супермаркетов в странах, подпадающих под статью 5, является отсутствие знаний о новых технологиях, ограниченная доступность компонентов оборудования, а также высокая начальная стоимость конверсии. Необходимо продемонстрировать техническую целесообразность конверсии, экологические выгоды, а также энергетическую эффективность использования CO₂ в централизованных холодильных системах супермаркетов, чтобы поощрять использование этой альтернативы и уменьшить зависимость от ГХФУ.

3. Этот проект направлен на внедрение сверхкритической технологии охлаждения на базе CO₂ в двух тщательно отобранных репрезентативных супермаркетах в Аргентине и Тунисе, которые расположены в умеренно теплых климатических зонах на двух континентах. На его основе будут рассматриваться долгосрочная устойчивость альтернативного хладагента и другие технические вопросы, связанные с простотой монтажа и затратами. При успешной реализации проекта предполагается его воспроизведение в странах в обоих регионах, что будет способствовать использованию хладагентов с низким ПГП в секторе сборки.

Реализация проекта

4. Супермаркеты "La Aponima" в городе Линкольн, Аргентина, и "Monoprix" в городе Тунисе, Тунис, были отобраны для перехода на сверхкритические технологии на базе CO₂. В обоих супермаркетах эксплуатируются централизованные системы холодильных установок с низкими и высокими температурами, в которых используется ГХФУ-22. Кроме того, в супермаркете "La Aponima" имеется ряд автономных морозильных установок, работающих на ГФУ-410А, а в супермаркете "Monoprix" работают морозильные островки с ГФУ-404А. Общий годовой объем хладагента для всех систем составляет 685 кг ГХФУ-22 (400 кг для Аргентины и 285 кг для Туниса) и 10,6 кг ГФУ-410А и 10 кг ГФУ-404А.

5. Будут спроектированы и установлены новые системы сверхкритических холодильных компрессоров на базе CO₂, в которых хладагентом на обоих стадиях (при средней и низкой температурах) является CO₂ с подсистемой охлаждения, которая будет работать с использованием ГФУ-410А или ГУ-290. Будут заменены также охлаждаемые морозильники и островные блоки. Будут испытаны общие системы охлаждения, чтобы оценить их производительность и энергоэффективность по сравнению с системой на базе ГХФУ-22. Собранная информация будет использоваться для разработки стандартов и руководящих принципов для проектирования,

¹ Финансирование подготовки этого проекта было утверждено на сумму 60 000 долл. США плюс вспомогательные расходы в 4 200 долл. США для ЮНИДО, при том понимании, что одобрение подготовки проекта не означает утверждение проектного предложения или его уровня финансирования, когда оно будет представлено на рассмотрение Исполнительного комитета (решение 74/33).

монтажа и обслуживания такого оборудования, и будет включена в окончательный отчет по проекту.

6. После успешного завершения проекта предлагается провести региональные семинары-практикумы, чтобы поделиться результатами со странами Латинской Америки, Ближнего Востока и Северной Африки и обеспечить возможность для проведения такой же работы на предприятиях, работающих в аналогичных условиях.

Проектные затраты

7. Общая стоимость проекта, на покрытие которой испрашивается финансирование, оценивается в 968 665 долл. США, в соответствии с первоначально представленными данными, которые приводятся в таблице 1.

Таблица 1. Предлагаемые проектные затраты

Описание	Аргентина	Тунис	Итого (долл. США)
Новое холодильное оборудование	389 867	245 347	635 214
Продуктовые прилавки-витрины	162 302	83 784	246 086
Инженерно-технические работы и транспорт	21 451	13 914	35 365
Семинары для распространения результатов проекта	28 000	24 000	52 000
Всего	601 620	367 045	968 665

КОММЕНТАРИИ И РЕКОМЕНДАЦИЯ СЕКРЕТАРИАТА

КОММЕНТАРИИ

8. ЮНИДО пояснила, что страны-получатели помощи были отобраны на основе их готовности к реализации проекта, обязательств со стороны выявленных супермаркетов, наличия сильных академических или научно-исследовательских институтов, а также поддержки, оказываемой действующим национальным органом по озону (НОО), который будет внимательно следить за осуществлением проекта. Учитывалось также географическое распределение, в том числе потенциал для глобального тиражирования проекта во многих супермаркетах, а также количество филиалов, в которых может быть гарантировано повторение результатов проекта.

9. Выбор технологии был основан на тщательном рассмотрении различных применений CO₂ в холодильной технике, принимая во внимание успех сверхкритических систем в Европе и Северной Америке. Была определена система параллельной компрессии как более выгодная с точки зрения простоты, влияния на климат и потребления энергии по сравнению с каскадными системами. В сочетании с системой бустер-компрессоров это обеспечивает более эффективный вариант и с точки зрения затрат. После этого тщательного анализа была отобрана технология, основанная на сверхкритической системе бустер-компрессоров на базе CO₂ с параллельным сжатием и переохлаждением и использованием R-410A (вариант 1) или HC-290 (вариант 2) и без вторичного хладагента (CO₂ будет циркулировать в охлаждающем контуре).

10. ЮНИДО также пояснила, что аналогичный проект, финансируемый Коалицией по проблемам климата и чистого воздуха (ССАС), рассматривался в одном из супермаркетов в Чили, но никакие его уроки не могут быть использованы, так как его реализация продолжается до сих пор. Предлагаемый проект предполагает рассмотреть более современные сверхкритические технологии, чем технологии, используемые в Чили, что позволит внести новый вклад во взаимодействие между аналогичными проектами в регионе.

11. Что касается дальнейшей оптимизации проектных затрат², то ЮНИДО скорректировала стоимость проекта за счет сокращения расходов на оборудование, связанное с прилавками-витринами, а также расходов на инженерно-технические работы и проведение семинаров. Окончательные расходы по проекту, запрашиваемые у Фонда, составляют 846 300 долл. США плюс вспомогательные расходы учреждения (таблица 2).

Таблица 2. Окончательные предлагаемые затраты

Описание	Аргентина	Тунис	Всего
Новое холодильное оборудование	389 866	245 347	635 213
Продуктовые прилавки-витрины	102 303	43 784	146 087
Инженерно-технические работы и транспорт	15 000	10 000	25 000
Семинары для распространения результатов проекта	20 000	20 000	40 000
Всего	527 169	319 131	846 300

Вывод

12. Если данный проект окажется успешным, то он обеспечит жизнеспособные технологии с низким ПГП для замены ГХФУ-22, используемые в супермаркетах и для хранения в условиях холода, с потенциалом для повышения энергетической эффективности новой системы охлаждения. Были получены письма от правительств как Аргентины, так и Туниса, в которых выражается поддержка этому проекту.

РЕКОМЕНДАЦИЯ

13. Исполнительный комитет, возможно, пожелает рассмотреть следующие положения:

- a) Демонстрационный проект по внедрению сверхкритической технологии охлаждения на базе CO₂ в супермаркетах Аргентины и Туниса, описание которого содержится в настоящем документе, а также обзор проблем, выявленных в ходе рассмотрения проекта (UNEP/ozl.Pro/excom/76/12);
- b) Утверждение демонстрационного проекта по внедрению сверхкритической технологии охлаждения на базе CO₂ в супермаркетах Аргентины и Туниса на сумму в 846 300 долл. США плюс вспомогательные расходы на сумму 59 241 для ЮНИДО, в соответствии с решением 72/40; и
- c) Призвать правительства Аргентины и Туниса, а также ЮНИДО завершить осуществление проекта в соответствии с планом в течение 30 месяцев, и представить всеобъемлющий окончательный доклад вскоре после завершения проекта.

² В соответствии с решением 74/21 с), двусторонним исполнителям и учреждениям-исполнителям было предложено оптимизировать расходы на демонстрационные проекты, чтобы можно было утвердить больше демонстрационных проектов в рамках имеющихся финансовых средств в размере 10 миллионов долл. США, в соответствии с решением 72/40, а также продолжить изучение других источников дополнительного финансирования.

ОЦЕНОЧНЫЙ ЛИСТ ПРОЕКТА - НЕ МНОГОЛЕТНИЙ ПРОЕКТ
Глобальный

НАИМЕНОВАНИЕ ПРОЕКТА **ДВУСТОРОННИЙ / УЧРЕЖДЕНИЕ-ИСПОЛНИТЕЛЬ**

а) Демонстрационный проект по качеству хладагента, мерам сдерживания и внедрению хладагентов с низким потенциалом глобального потепления (ПГП)	ЮНИДО, ведущее учреждение-исполнитель ЮНЕП, сотрудничающее учреждение
--	--

Национальное координирующее учреждение	Национальные органы по озону
---	------------------------------

ПОСЛЕДНИЕ ПРЕДСТАВЛЕННЫЕ ДАННЫЕ О ПОТРЕБЛЕНИИ ОРВ, УКАЗАННЫХ В ПРОЕКТЕ

А: ДАННЫЕ ПО СТАТЬЕ 7

ГХФУ	не прим.
------	----------

В: ДАННЫЕ СТРАНОВОЙ ПРОГРАММЫ ПО СЕКТОРАМ: не прим.

Потребление ГХФУ, все еще подпадающее под финансирование (в тоннах ОРП)	не прим.
--	----------

ВЫДЕЛЕНИЕ СРЕДСТВ ПО БИЗНЕС-ПЛАНУ НА ТЕКУЩИЙ ГОД	Финансирование в долл. США	Поэтапный отказ в тоннах ОРП
а)	не прим.	не прим.

НАИМЕНОВАНИЕ ПРОЕКТА:	
Использование ОРВ на предприятии (в тоннах ОРП)	не прим.
Поэтапный отказ от ОРВ (в тоннах ОРП)	не прим.
ОРВ, подлежащие поэтапному внедрению (в тоннах ОРП)	не прим.
Продолжительность проекта (в месяцах)	24 месяца
Первоначальная запрашиваемая сумма (долл. США)	1 105 100
Окончательные затраты на проект (долл. США)	
Подпроект 1: бывшая югославская Республика Македония	280 000
Подпроект 2: Египет	130 000
Подпроект 3: Мексика	150 100
Подпроект 4: Карибский регион	220 000
Подпроект 5: регион Восточной Африки	175 000
Общая стоимость проекта	955 100
Местное доленое участие (%)	100%
Экспортный компонент (%)	не прим.
Выделение средств ЮНИДО (долл. США)	870 100
Вспомогательные расходы учреждения-исполнителя (долл. США)	60 907
Выделение средств ЮНЕП (долл. США)	85 000
Вспомогательные расходы учреждения-исполнителя (долл. США)	11 050
Общая стоимость проекта для Многостороннего фонда (долл. США)	1 027 057
Статус финансирования контрагента (Да / Нет)	Да
Включены этапы мониторинга проекта (Да / Нет)	Да

РЕКОМЕНДАЦИЯ СЕКРЕТАРИАТА	Для индивидуального рассмотрения
----------------------------------	----------------------------------

ОПИСАНИЕ ПРОЕКТА

Базовая информация

14. ЮНИДО в качестве ведущего учреждения-исполнителя представила на рассмотрение 76-го совещания просьбу о финансировании демонстрационного проекта по качеству хладагента, мерам сдерживания и внедрению альтернативных хладагентов с низким потенциалом глобального потепления (ПГП) от имени правительств стран, участвующих в проекте и подпадающих под положения статьи 5³. Общая стоимость проекта составляет 1 188 157 долл. США, которая включает затраты на уровне 1 010 100 долл. США плюс вспомогательные расходы учреждения-исполнителя в размере 70 707 долл. США для ЮНИДО, а также затраты 95 000 долл. США плюс вспомогательный расходы в размере 12 350 долл. США для ЮНЕП⁴. Проектное предложение содержится в Приложении II к настоящему документу.

15. Во время подготовки этого проектного предложения ЮНЕП и ЮНИДО определили следующие три основные проблемы в секторе обслуживания холодильного оборудования, которые в значительной степени способствует выбросу хладагентов ОРВ и их воздействию на климат с учетом их ПГП:

- a) Нестабильный характер и ненадежное качество хладагентов. Использование смесей хладагентов, неправильная маркировка хладагентов (из-за недостатков нормативной правовой базы) и/или ограниченные технические знания среди технических специалистов, которые в частности становятся причиной нарушения безопасности, неэффективного обслуживания и неправильной эксплуатации холодильного и морозильного оборудования, что приводит к увеличению случаев утечек, снижению сроков службы оборудования и увеличению воздействия на окружающую среду;
- b) Высокий уровень утечки хладагентов. Утечка и выбросы в атмосферу хладагентов при техническом обслуживании и эксплуатации холодильного оборудования имеют высокий уровень из-за отсутствия профилактики и обеспечения герметичности хладагента, неадекватного уровня технических знаний и практических навыков технических специалистов, отсутствия средств обслуживания, включая оборудование по обнаружению утечки, а также из-за недостаточного уровня информированности о воздействии на окружающую среду плохой герметизации хладагентов; и
- c) Барьеры для внедрения альтернативных хладагентов с низким ПГП. Значительная часть оборудования, имеющегося в продаже сегодня в секторе холодильных установок и систем кондиционирования воздуха, эксплуатируется с применением ГХФУ-22 и/или хладагентов ГФУ с высоким уровнем ПГП. Внедрение альтернативных хладагентов с низким ПГП и использование холодильного оборудования, эксплуатируемого на основе хладагентов с низким ПГП (таких как HC-600A, HC-290, CO₂, NH₃, ГФО-1234yf, ГФУ-32, смеси ГФО/ГФУ), требует повышения квалификации для монтажа, эксплуатации и технического обслуживания оборудования, работающего с такими хладагентами, принимая во внимание, что некоторые из этих хладагентов являются воспламеняющимися (или слабо воспламеняющимися) и/или токсичными веществами.

³ Глобальный: Египет, Гренада в качестве ведущей страны для отдельных стран Карибского бассейна (Багамские острова, Сент-Люсия, Сент-Винсент и Гренадины, Суринам), бывшая югославская Республика Македония, Мексика, Объединенная Республика Танзания в качестве ведущей страны для отдельных стран Восточной Африки (Эритрея, Кения, Уганда, Замбия).

⁴ Финансирование подготовки этого проекта было утверждено в размере 150 000 долл. США плюс вспомогательные расходы на сумму 10 500 долл. США при том понимании, что его утверждение не означает утверждения проекта или его уровня финансирования при представлении (решение 74/33).

Цели проекта

16. Для того чтобы лучше понимать вышеупомянутые проблемы и предложить меры для успешного их решения, в рамках этого глобального демонстрационного проекта предлагается осуществить следующие пять подпроектов в ряде стран, подпадающих под положения статьи 5, каждый из которых будет преследовать конкретные цели:

- a) Подпроект 1: Целостный подход к повышению уровня обслуживания в секторе холодильного оборудования, который будет осуществляться в бывшей югославской Республике Македонии;
- b) Подпроект 2: Меры сдерживания хладагентов и предотвращение утечки хладагентов исходя из инициативы достижения реального нулевого уровня утечки⁵, который будет осуществляться в Египте;
- c) Подпроект 3: Инновационные меры для минимизации отходов хладагентов и меры безопасности при работе с извлекаемыми хладагентами, который будет осуществляться в Мексике;
- d) Подпроект 4: Меры безопасности при работе с воспламеняющимися хладагентами с низким ПГП, который будет осуществляться в пяти странах Карибского региона (Багамские острова, Гренада, Сент-Люсия, Сент-Винсент и Гренадины, Суринам); и
- e) Подпроект 5: Стандарты и наличие на рынке качественных хладагентов, который будет осуществляться в пяти странах Восточной Африки (Эритрея, Кения, Уганда, Объединенная Республика Танзания и Замбия).

Реализация проекта

17. Ниже приводится краткое описание конкретных мероприятий и стоимость каждого из пяти подпроектов.

Подпроект 1: Целостный подход к повышению уровня обслуживания в секторе холодильного оборудования, который будет осуществляться в бывшей югославской Республике Македонии (ЮНИДО) (24 месяца)

18. Подпроект предполагает целостный подход в секторе обслуживания холодильного оборудования на основе одновременного решения трех выявленных проблем, следующим образом:

- a) Повышение качества хладагентов, а также сокращение утечки и выбросов хладагентов и их компонентов предусматривает оказание помощи по вопросам политики; формирование "мобильной службы тестирования хладагентов", предоставление инструментов для обслуживания и обучение технического персонала; и укрепление системы регистрации и маркировки;

⁵ Инициатива реального нулевого уровня выбросов и утечки хладагентов (Real Zero) содержит рекомендации о сокращении утечек хладагентов, инструменты для распространения среди клиентов информации о важности уменьшения утечки, шаблоны для проведения обследований на местах и отчетов о расходах, связанных с утечкой, учебные материалы для повышения уровня знаний технических специалистов и операторов, а также план факультативной сертификации и оценки.

- b) Создание системы регенерации хладагентов будет базироваться на разработке бизнес-модели для обеспечения долгосрочного и устойчивого характера системы регенерации, а также будет включать базовое оборудование, обучение технического персонала и мониторинг; и
- c) Продвижение альтернативных хладагентов с низким ПГП обеспечит демонстрационные блоки, работающие на природных хладагентах, и инструменты для двух демонстрационных учебных центров, разработку учебной программы, обучение и сертификацию технических специалистов, повышение уровня информированности и проведение регионального совещания группы экспертов.

19. Общая стоимость подпроекта 1 оценивается в 300 000 долл. США, как указано в таблице 2.

Таблица 2: Ориентировочные затраты на подпроект 1 в бывшей югославской Республике Македонии

Описание	Затраты (долл. США)
Национальные эксперты (консультирование по вопросам политики, разработка системы маркировки хладагентов, оценка потребностей для центров регенерации, проектирование мобильной службы тестирования хладагентов, организация подготовки технических специалистов, участие в мероприятиях по повышению осведомленности, оценка результатов)	20 000
Международный эксперт (разработка и мониторинг плана действий по предотвращению утечки, формирование мобильной службы тестирования хладагентов, а также бизнес-модель регенерации)	35 000
Оборудование (одна демонстрационная установка с низким ПГП, инструменты и три машины для регенерации)	152 500
Обучение (инспекторы охраны окружающей среды, технические специалисты, сотрудники центра регенерации)	30 000
Качество и утечка хладагента (разработка, создание и мониторинг мобильной службы тестирования хладагентов, создание системы маркировки и разработка плана действий по предотвращению утечки)	42 500
Повышение осведомленности	20 000
Итого затраты	300 000

Подпроект 2: Меры сдерживания хладагентов и предотвращение утечки хладагентов исходя из инициативы достижения реального нулевого уровня утечки, который будет осуществляться в Египте (ЮНЕП, ЮНИДО) (18 месяцев)

20. Подпроект предполагает поощрять меры сдерживания хладагентов и снижение утечки за счет применения передового опыта в обслуживании/технической профилактике холодильного оборудования и систем кондиционирования воздуха (РАС), обучения и повышения осведомленности об эффективности и рентабельности подходов, основанных на мерах сдерживания и снижении утечек хладагентов. Он будет опираться на систему единой сертификации Европейского союза и инициативу реального нулевого уровня утечек, реальные квалификационные навыки Европы будут служить в качестве инструмента по обеспечению соблюдения национального кодекса Египта для холодильного оборудования и систем кондиционирования воздуха. Мероприятия, которые будут реализованы в рамках подпроекта, приведены в таблице 3 ниже.

21. Общие затраты на подпроект 2 оцениваются на уровне 150 000 долл. США, как указано в таблице 3.

Таблица 3: Ориентировочные затраты на подпроект 2 в Египте

Описание	Затраты (долл. США)		
	ЮНИДО	ЮНЕП	Итого
Обследование и определение целевого сектора	30 000		30 000
Оценка национального потенциала		10 000	10 000
Разработка и осуществление программы обучения	60 000		60 000
Разработка и осуществление программы сертификации		20 000	20 000
Оценка и распространение результатов	20 000	10 000	30 000
Итого затраты	110 000	40 000	150 000

Подпроект 3: Инновационные меры для минимизации отходов хладагентов и меры безопасности при работе с извлекаемыми хладагентами, который будет осуществляться в Мексике (ЮНИДО) (18 месяцев)

22. Подпроект предполагает усовершенствовать меры сдерживания хладагентов путем продления срока полезной жизни хладагентов и разработать экономически жизнеспособную систему мер безопасности при работе с хладагентами и их утилизации. Такой подход обеспечит снижение потерь хладагентов из-за потерь и/или выбросов в атмосферу, повышение осведомленности об экологических и экономических выгодах, связанных с мерами сдерживания хладагентов; разработку и внедрение политики поддержки мер сдерживания хладагентов; определение технических и экономических условий для работы с хладагентами с высоким ПГП; повышение устойчивости существующих систем обработки хладагентов.

23. Общие затраты на подпроект 3 оцениваются на уровне 225 100 долл. США, как указано в таблице 4.

Таблица 4: Ориентировочные затраты на подпроект 3 в Мексике

Описание	Затраты (долл. США)
Переклассификация хладагентов в качестве опасных отходов	30 000
Всеобъемлющая стратегия управления минимизацией отходов хладагентов	30 000
Программы профессиональной подготовки и повышения осведомленности	40 000
Распространение опыта	45 000
Повышение технического потенциала отобранных центров по сбору и утилизации	80 100
Итого затраты	225 100

Подпроект 4: Меры безопасности при работе с воспламеняющимися хладагентами с низким ПГП, который будет осуществляться в пяти странах Карибского региона (Багамские острова, Гренада, Сент-Люсия, Сент-Винсент и Гренадины, Суринам) (ЮНИДО) (18 месяцев)

24. Подпроект предполагает содействовать безопасному внедрению хладагентов с низким ПГП путем повышения опыта и знаний технических специалистов; модернизацию учебных программ в профессионально-технических центрах; предоставление оборудования для регионального учебного центра; и демонстрацию для заинтересованных сторон существующего на рынке новейшего оборудования и его компонентов на базе углеводорода. Планируемые мероприятия в рамках проекта будут осуществляться в рамках планов деятельности по поэтапному отказу от ГХФУ (ПОДПО) стран-участниц (Гренада была выбрана в качестве ведущей пилотной страны).

25. Общие затраты на подпроект 4 оцениваются на уровне 220 000 долл. США, как указано в таблице 5.

Таблица 5: Ориентировочные затраты на подпроект 4 в Карибском регионе

Описание	Затраты (долл. США)
Разработка учебной программы и мониторинг программ подготовки	30 000
Модернизация учебных центров	66 000
Проведение регионального семинара по подготовке инструкторов	39 000
Семинар и выставка	5 000
Учебные занятия для специалистов по техническому обслуживанию	45 000
Региональное совещание экспертов и распространение результатов	35 000
Итого затраты	220 000

Подпроект 5: Стандарты и наличие на рынке качественных хладагентов, который будет осуществляться в шести странах Восточной Африки (Эритрея, Кения, Уганда, Объединенная Республика Танзания и Замбия) (ЮНИДО и ЮНЕП) (18 месяцев)

26. Подпроект направлен на содействие более безопасной и эффективной эксплуатации оборудования в секторе РАС за счет повышения доступности качественных хладагентов, укрепления системы сертификации и механизмов контроля, а также повышения осведомленности среди ключевых заинтересованных сторон (Объединенная Республика Танзания была выбрана в качестве ведущей пилотной страны).

27. Общие затраты на подпроект 5 оцениваются на уровне 210 000 долл. США, как указано в таблице 6.

Таблица 6: Ориентировочные затраты на подпроект 5 в регионе Восточной Африки

Описание	Затраты (долл. США)		
	ЮНИДО	ЮНЕП	Итого
Компонент политики			
Оценка текущих рамок национальной политики в Эритрее, Кении, Уганде и Замбии	20 000		20 000
Анализ национального отставания в области оценки, координация деятельности, монтаж, служба тестирования и система маркировки в Объединенной Республике Танзании	10 000		10 000
Техническая консультативная группа во всех шести странах	35 000		35 000
Компонент технической помощи			
Оснащение и обучение заинтересованных сторон во всех шести странах	65 000		65 000
Мобильная служба тестирования хладагентов, система маркировки, включая введение стандартов и руководящих принципов, касающихся контейнеров для хладагентов, в Объединенной Республике Танзании	25 000	35 000	60 000
Компонент осведомленности			
Повышение осведомленности в целях содействия системам маркировки во всех шести странах		20 000	20 000
Итого затраты	175 000	55 000	210 000

Бюджет проекта

28. Общие затраты на глобальный демонстрационный проект оцениваются в 1 105 100 долл. США, как указано в таблице 7.

Таблица 7. Предлагаемые глобальные затраты на проект

Описание	Затраты (долл. США)
Бывшая югославская Республика Македония	300 000
Мексика	225 100
Египет	150 000
Карибский регион	220 000
Регион Восточной Африки	210 000
Общая сумма	1 105 100

КОММЕНТАРИИ И РЕКОМЕНДАЦИЯ СЕКРЕТАРИАТА

КОММЕНТАРИИ

Оптимизация затрат на проект

29. На 74-м совещании ЮНИДО представила заявки на финансирование (150 000 долл. США) подготовки трех демонстрационных проектов в секторе обслуживания холодильного оборудования в Египте, Восточной Африке (Кения, Объединенная Республика Танзания, Уганда и Замбия), а также в Карибском регионе (Багамские острова, Гренада, Сент-Люсия, Сент-Винсент и Гренадины, Суринам). Учитывая аналогичный характер этих проектов, Исполнительный комитет просил ЮНИДО объединить предложения в рамках одной глобальной концепции, нацеленной на меры сдерживания хладагентов и внедрение альтернативных хладагентов с низким ПГП в секторе холодильного оборудования и систем кондиционирования воздуха в отдельных странах, подпадающих под положения статьи 5 (решение 74/33).

30. Секретариат с удовлетворением отметил, что в соответствии с решением 74/21 с), ЮНИДО оптимизировала общие затраты на глобальный проект, представленный на 76-м совещании (на уровне 1 105 100 долл. США), от общих затрат на уровне 1 846 610 долл. США на три демонстрационных проекта, которые изначально планировались ЮНИДО. В ходе обсуждений при рассмотрении проекта ЮНИДО согласилась снизить затраты на демонстрационный проект до 955 100 долл. США. Кроме того, предложение, представленное на 76-м совещании, включает в себя более значительный объем деятельности и больше стран.

Добавленная стоимость предлагаемых демонстрационных мероприятий

31. Секретариат отметил, что некоторые из мероприятий, включенных в демонстрационный проект, как представляется, уже реализованы в странах, подпадающих под положения статьи 5, на основе их ПОДПО, что ставит под сомнение демонстрационную ценность проекта. ЮНИДО пояснила, что многие из предложенных мероприятий не были реализованы в прошлом (например, создание мобильной службы тестирования хладагентов, применение подхода к уменьшению утечек на основе инициативы нулевого уровня, сертификация зданий и помещений, а не физических лиц), в то время как другие мероприятия, осуществляемые в соответствии с прежними или текущими планами поэтапного отказа от ОРВ, не в полной мере достигли своих целей (например, повторное использование или хранение собранных или утилизированных хладагентов для использования в будущем). Для устранения этих недостатков были приняты во внимание опасения, высказанные странами, подпадающими под положения статьи 5, и передовая практика, применяемая в странах, не подпадающих под положения статьи 5. Мероприятия, предлагаемые в демонстрационном проекте, являются дополнительными видами деятельности по отношению к ПОДПО и направлены на то, чтобы сделать их результаты устойчивыми. ЮНИДО также указала на необходимость системного подхода к внедрению альтернативных хладагентов с низким ПГП в странах, подпадающих под положения статьи 5.

32. В то время как некоторые из мероприятий, предложенных в рамках демонстрационного проекта, потенциально могут способствовать внедрению хладагентов с низким ПГП (например, компоненты в Карибском бассейне и регионе Восточной Африки), в деятельности, связанной со сдерживанием и снижением утечки хладагентов, основное внимание сосредоточено на сохранении ГХФУ-22. Уроки, извлеченные из этих мероприятий, едва ли можно тиражировать, так как они будут в значительной степени зависеть от местных условий, о чем свидетельствуют большинство осуществленных до настоящего времени проектов по обслуживанию холодильных установок и по утилизации ОРВ. ЮНИДО пояснила, что подход, основанный на достижении реального нулевого уровня утечек, используемый в ряде стран, не подпадающих под положения статьи 5, легко повторить, но он не был внедрен в странах, подпадающих под положения статьи 5. Укрепление мер сдерживания хладагента позволит снизить риски, связанные с использованием воспламеняющихся хладагентов с низким ПГП.

Подпроект в бывшей югославской Республике Македонии

33. Секретариат поставил под сомнение необходимость повторять в этом подпроекте мероприятия, включенные в остальные четыре подпроекта. ЮНИДО указала, что выбор бывшей югославской Республики Македонии в качестве ведущей пилотной страны был основан на том, что стратегия, которая будет осуществляться, требует хорошо развитой и стабильной основы с точки зрения в частности политики, технологии, сбора и утилизации, а также инфраструктуры профессиональной подготовки. Страна была выбрана для проверки всех мероприятий, предлагаемых в рамках демонстрационного проекта, на основе комплексного подхода, учитывая существующую надежную нормативную правовую базу и успехи в осуществлении деятельности в секторе обслуживания хладагентов.

Подпроект в Египте

34. При обосновании подпроекта в Египте, учитывая, что подобные мероприятия уже успешно проводились в рамках многих ПОДПО, ЮНИДО пояснила, что проект направлен на рассмотрение мер сдерживания хладагентов за счет более надежного и всеобъемлющего подхода (реальный нулевой уровень утечки), который не был включен на этапе I осуществления ПОДПО для Египта и который можно было бы повторить, по крайней мере, в странах Северной Африки. Этот подпроект также предполагает выдачу сертификатов для зданий, помещений и объектов, которые соответствуют требованиям национального кодекса по вопросам охлаждения и мер сдерживания хладагентов, что предусматривает дополнительную ответственность конечных пользователей за выполнение обязательств по мерам сдерживания по сравнению с подготовкой отдельных лиц в соответствии с положениями ПОДПО.

Подпроект в Мексике

35. При обосновании подпроекта в Мексике вне рамок существующего ПОДПО, ЮНИДО указала, что в то время как на этапе II ПОДПО предусматривается модернизация двух крупных центров по сбору и утилизации хладагентов, настоящий подпроект направлен на то, чтобы продемонстрировать, каким образом классификация использованных хладагентов в качестве опасных отходов позволит более мелким центрам по сбору и утилизации хладагентов проводить такую же работу, так как в настоящее время в связи с отсутствием каких-либо правовых мер нет никаких финансовых стимулов для их сбора и утилизации. Финансирование, запрашиваемое для проведения лабораторных анализов собранных хладагентов, предусматривает укрепление доверия клиентов, готовых использовать бывшие в употреблении хладагенты, поступающие из малых и средних центров восстановления, которые не очень хорошо оборудованы. Создание благоприятных условий для работы более мелких и средних восстановительных центров позволит повысить эффективность затрат, связанных со сбором хладагентов, так как это приведет также к снижению транспортных расходов.

Подпроект в Карибском регионе

36. При предоставлении дополнительной информации о подпроекте для Карибского региона, ЮНИДО пояснила, что были проблемы в прошлом, когда поставщики оборудования для кондиционирования воздуха, работающего на базе углеводородных хладагентов, отказывались взаимодействовать с той или иной страной, поскольку их волновали вопросы ответственности, так как они считают, что в стране отсутствуют подготовленные технические специалисты, способные работать на таком оборудовании. Этот демонстрационный проект будет направлен на преодоление этой озабоченности путем разработки учебной программы для работы с воспламеняющимися хладагентами в профессионально-технических центрах и организации обучения и технической сертификации по использованию воспламеняющихся хладагентов. Будет проводиться политика, требующая сертификации для работы с воспламеняющимися хладагентами. Бюджеты для финансирования ПОДПО в соответствующих странах не смогли бы охватить все эти мероприятия без демонстрационных проектов, но мероприятия в рамках демонстрационного проекта могут быть интегрированы посредством ПОДПО.

Подпроект в регионе Восточной Африки

37. Освещая вопрос о демонстрации ценности стандартов и доступности на рынке качественных хладагентов в регионе Восточной Африки, ЮНИДО пояснила, что содействие более безопасной и эффективной эксплуатации оборудования имеет большое значение для внедрения хладагентов с низким ПГП. В рамках ПОДПО частично рассматриваются стандарты качества, но до настоящего времени этому вопросу не уделялось должное внимание в любом из проектов в Восточной Африке. Кроме того, идентификация и ориентирование дилеров и предприятий розничной торговли представляют собой деятельность, которая никогда не проводилась в рамках проектов, финансируемых за счет Многостороннего фонда. В обоснование необходимости в идентификаторах хладагентов, которые, как правило, финансируются в рамках ПОДПО, ЮНИДО пояснила, что включенные в проект идентификаторы хладагентов предназначены для инспекторов охраны окружающей среды (мобильной службы тестирования хладагентов в Объединенной Республике Танзании). Новые идентификаторы охватывают более широкий диапазон газов, в том числе смеси ГФУ, углеводороды и ГФО.

Письма в поддержку

38. Секретариат отметил, что представление включает письма, в которых выражается поддержка осуществлению подпроектов в бывшей югославской Республике Македонии и Мексике. Остальные подпроекты содержат те же письма с поддержкой, которые были представлены на 74-м совещании в рамках просьбы о финансировании подготовительной работы для этого демонстрационного проекта. ЮНИДО отметила, что были запрошены новые письма с поддержкой из этих стран, но не все из них были получены к моменту выпуска настоящего документа.

Вывод

39. Секретариат отметил, что сектор обслуживания холодильного оборудования не является одним из приоритетных секторов для обеспечения финансирования демонстрационного проекта; тем не менее, некоторые из компонентов, как представляется, имеют значение для демонстрации надлежащего внедрения альтернативных хладагентов с низким ПГП в странах, подпадающих под положения статьи 5. Хотя и была проделана большая работа в рамках ПОДПО с точки зрения контроля за утечкой хладагентов и мер сдерживания хладагентов, применение систем, направленных на сведение к минимуму отходов хладагентов, и подход, обеспечивающий реальный нулевой уровень утечки хладагентов, могут оказаться весьма полезными. Проект будет осуществляться в ряде стран, а предлагаемые мероприятия связаны с их ПОДПО. Учитывая, что

сектор обслуживания холодильного оборудования не был определен в качестве приоритетного, утверждение настоящего предложения будет зависеть от обсуждения в Исполнительном комитете всех демонстрационных проектов.

РЕКОМЕНДАЦИЯ

40. Исполнительный комитет, возможно, пожелает рассмотреть следующие положения:
- a) Демонстрационный проект по качеству хладагентов, мерам сдерживания и внедрению альтернативных хладагентов с низким потенциалом глобального потепления (ПГП) в контексте обсуждения предложений, касающихся демонстрационных проектов по хладагентам с низким ПГП, которые служили бы альтернативой ГХФУ, как это описано в документе по обзору проблем, выявленных в ходе рассмотрения проекта (UNEP/ozl.Pro/excom/76/12);
 - b) Следует ли утвердить демонстрационный проект по качеству хладагентов, мерам сдерживания и внедрению альтернативных хладагентов с низким потенциалом глобального потепления (ПГП).

Annex I



DEMONSTRATION PROJECT IN THE REFRIGERATION ASSEMBLY SECTOR

PROJECT COVER SHEET

PROJECT TYPE TITLE	DEMONSTRATION PROJECT: DEMONSTRATION PROJECT IN THE REFRIGERATION ASSEMBLY SECTOR	
COUNTRY NAME	Argentina Tunisia	
LEAD IMPLEMENTING AGENCY	UNIDO	
COOPERATING IMPLEMENTING AGENCY	None	
NATIONAL COUNTERPART	National Ozone Units of Argentina and Tunisia	
SECTOR	Refrigeration	
SUB-SECTOR	Commercial refrigeration	
PROJECT STAKEHOLDERS	Supermarket La Anonima, Lincoln, Argentina Supermarket Monoprix, Tunis, Tunisia	
HCFC PHASED-OUT (ANNUAL AVERAGE)	Argentina: 367 kg of R-22 and 34kg of HFC-404A Tunisia: 238 kg of R-22 and approximately 20kg of HFC-404A	
PROJECT COSTS [USD]	Argentina	527,169
	Tunisia	319,131
	Total	846,300
MLF REQUESTED FUNDING [USD]	846,300	
UNIDO FUNDING ALLOCATION [USD]	846,300	
UNIDO SUPPORT COSTS 7% [USD]	59,241	
TOTAL PROJECT COSTS	905,541	
PROJECT DURATION	30 Months	

PROJECT SUMMARY

Annex I



DEMONSTRATION PROJECT IN THE REFRIGERATION ASSEMBLY SECTOR

Significant amount of R-22 is used in commercial refrigeration systems and introduction of alternative refrigerants would significantly contribute to the country's compliance. The objective of the project is to phase out HCFCs and leapfrog the HFC conversion step through

1. Introduction of trans-critical CO₂ in two carefully selected representative supermarkets, both located in moderately warm climatic conditions on two continents.
2. Address long-term sustainability and reduce TEWI of the refrigeration system through enhancement of its electrical energy efficiency.
3. Widen the impact of this demonstration project and open avenues for replication on country level, regionally and globally.

The demonstration project will be implemented concurrently in two different countries namely Tunisia and Argentina in order to generate more lessons learned

It should be noted that in Tunisia, a research team in an academic institution is currently conducting research work on CO₂-based systems for commercial and industrial applications. The project will benefit from their work and will help them have an application to it.

After completion of the project it is planned to share the know-how and experience learned with other interested domestic and foreign enterprises in both regions (Latin America and MENA countries) and enable replication by enterprises working in similar conditions.

DEMONSTRATION PROJECT

INTRODUCTION OF CO₂ REFRIGERATION TECHNOLOGY FOR SUPERMARKETS

IMPLEMENTING AGENCY: UNIDO



PROJECT MANAGER: MR. MANUEL CABALLERO ALARCON

PREPARED BY UNIDO: MR. TAMAS GROF, INTERNATIONAL CONSULTANT
MR. RICARDO BARROSO CELA, INTERNATIONAL
CONSULTANT
MS. MARTA COMTE, NATIONAL CONSULTANT
IN COOPERATION WITH: OZONE OFFICE OF ARGENTINA AND TUNISIA

14 March 2016

TABLE OF CONTENTS

CONTEXT	5
OBJECTIVES AND OUTPUTS	6
STRATEGY OF IMPLEMENTATION	6
PROPOSED TECHNOLOGY	7
CO ₂ (R-744) TECHNOLOGY.....	7
TECHNICAL PROPERTIES OF R-744	9
TECHNOLOGICAL OPTIONS FOR CO ₂ SYSTEMS.....	16
A. <i>Transcritical systems</i>	16
B. <i>Cascade systems</i>	18
C. <i>Secondary systems</i>	19
D. <i>Latest technological developments</i>	21
TECHNOLOGY SELECTION	24
PROJECT BUDGET	25
IMPLEMENTATION SCHEDULE	27
SUB-PROJECT 1: ARGENTINA	28
RECIPIENT COMPANY BACKGROUND.....	28
A. <i>Location of the Supermarket</i>	28
B. <i>GENERAL INFORMATION OF THE STORE</i>	30
C. <i>Overall description of baseline equipment</i>	32
D. <i>Description of the refrigeration machinery:</i>	35
E. <i>STORAGE AREA</i>	37
F. <i>SALES AREA</i>	42
INCREMENTAL INVESTMENT COST	48
GENERAL CRITERIA OF EQUIPMENT SELECTION	48



NEW EQUIPMENT.....	49
A. Main compressor.....	49
B. Condenser.....	49
C. Evaporators.....	49
D. Refrigeration circuits.....	49
REFRIGERATION REQUIRMENTS.....	49
E. Refrigeration plant.....	51
F. Compressors for fresh food cabinets and cold rooms (medium temperature).....	51
G. Compressors for deep frozen food (low temperature).....	51
MAIN CHARACTERISTICS AND DIMENSIONS OF THE REFRIGERATION PLANT.....	51
H. Parallel compressor.....	53
I. Evaporators.....	53
J. Condensers.....	54
K. Subcooler.....	55
L. Instrumentation and controls.....	57
M. Remote display.....	57
N. Leak detector and alarm.....	58
INCREMENTAL INVESTMENT COST	60
A. Refrigeration equipment.....	60
B. Refrigeration appliances.....	61
ENVIRONMENT IMPACT	62
IMPACT ON THE OZONE LAYER	62
TEWI - CLIMATE IMPACT CALCULATION	63
REFRIGERATED DISPLAY CABINETS FOR CO ₂ TECHNOLOGY.....	73
SUB-PROJECT 2: TUNISIA.....	80
RECIPIENT COMPANY BACKGROUND.....	80
LOCATION OF THE SUPERMARKET.....	81
GENERAL INFORMATION ON THE STORE.....	82
C. Compressors for fresh food cabinets and cold rooms (medium temperature).....	95
D. Compressors for deep frozen food (low temperature).....	95
E. Main characteristics and dimensions of the refrigeration plant.....	96
F. Parallel compressor.....	97
INCREMENTAL INVESTMENT COST	102
REFRIGERATION EQUIPMENT	102
REFRIGERATION APPLIANCES.....	102
ENVIRONMENT IMPACT	104
IMPACT ON THE OZONE LAYER	104
TEWI - CLIMATE IMPACT CALCULATION	104
IMPLEMENTATION SCHEDULE.....	112
REFRIGERATED DISPLAY CABINETS FOR CO₂ TECHNOLOGY	113



CONTEXT

In Article 5 countries a substantial amount of HCFC-22 is used in systems charged on-site, such as supermarkets and condensing units.

In recent years, in view of the growing concern of climate change, new technologies with very low GWP alternatives were developed, matured, came on the market and spreading fast in many A2 countries. Among them CO₂ is gaining popularity and is considered the refrigerant of the future in commercial refrigeration.

Currently the main barrier for introducing low-GWP alternatives, especially CO₂ in the supermarket sector of Article 5 countries is the lack of knowledge and experience as well as the limited availability of equipment components and know-how related to the new technology as well as the still elevated initial cost of conversion. For this reason, even when end-users decide to phase-out HCFC-22 from their installations, the likelihood that they would opt for HFC's (mainly HFC-404A) is rather high as HFC-404A technology has been well-known and in use e.g. in Argentina since 2008. Conversion to HFC-404A technology requires the least modification, so it is associated with the lowest investment cost. As a result, while phase-out of HCFC-22 will be achieved, it is highly unlikely to gain any additional climate and environment benefit (direct and indirect) to the actual HCFC phase-out.

Therefore, it is timely and highly desirable to prepare and implement a pilot project that would demonstrate the

- i. Technical viability,
- ii. Cost implications,
- iii. Environmental benefits,
- iv. Impact on the energy consumption,
- v. Incremental operating costs/savings and
- vi. Other advantages and disadvantages

of introduction of CO₂ in the refrigeration systems in developing countries with above moderate and warm climatic conditions.

The application of CO₂ refrigerants in centralized supermarket refrigeration systems in countries with warm climatic conditions has only started in some A2 countries. Thus, the demonstration value of this project is very high for A5 countries. The case is similar to the early introduction of hydrocarbons in MP projects, which demonstrated how to narrow the technological gap between A2 and A5 countries and leapfrog the HCFC conversion step.



OBJECTIVES AND OUTPUTS

The objective of the project is to phase out HCFCs and leapfrog the HFC conversion step through:

- i. Introduction of trans-critical CO₂ in the commercial refrigeration system in moderately warm countries in two different continents.
- ii. Address long-term sustainability and reduce TEWI of the refrigeration system through enhancement of its electrical energy efficiency.
- iii. Widen the impact of this demonstration project and open avenues for replication on country level, regionally and globally.

In order for these objectives to be achieved, the following outputs are expected to be accomplished:

1. Demonstration of the design, installation and operation of a refrigeration system based on trans-critical CO₂ technology in two supermarkets which would support an increased national capacity in both countries to use trans-critical CO₂ refrigeration systems.
2. Strengthened capacity for training refrigeration technicians on the efficient and safe handling of the demonstrated technology.
3. Assessment of the energy efficiency of the trans-critical CO₂ system installed as compared to an HCFC-22 system.
5. Dissemination of information about the technology among end users, cooling systems designers and refrigeration technicians to promote its adoption as a low-GWP alternative to new applications and systems as a replacement for HCFCs.

STRATEGY OF IMPLEMENTATION

The demonstration project will be implemented concurrently in two different countries namely Tunisia and Argentina in order to generate more lessons learned.

It is known, that CO₂ technology for supermarket applications has not yet been tried in most A5 countries. The reason is the elevated ambient temperature in most of the A5 countries. To encourage introduction and wide scale use of this innovative very low GWP technology UNIDO was identifying countries interested in this demonstration exercise.

The criteria of selection of an appropriate counterpart were:

1. Country where the Ozone unit is monitoring closely the implementation of MP activities and projects,
2. Country with relatively large and strong supermarket sector,
3. Country where institutional (academic) support is readily available,
4. Supermarkets operating in moderately hot area, where such technologies are not frequently used as yet (even in A2 countries),
5. Supermarkets with strong technical support team at least on corporate level (they are part of a larger chain of supermarkets),



6. Supermarkets which are ready to implement and support conversion to the novel and less known CO₂ technology and share the result of conversion with other domestic and foreign supermarkets,
7. A5 ownership is a fundamental criterion, thus branches of international supermarket chains could not apply.

Both Argentina and Tunisia qualify to the said criteria. They have well established and experienced Ozone units closely monitoring implementation. In both countries there are university scientists and engineering companies working in the field and in Tunisia there is an ongoing research project on CO₂ technology.

Both supermarkets are part of a local supermarket chain (in Tunisia and Argentina respectively) each operating large number of supermarkets domestically. The corporate level technical support staff is strong. The companies agreed to implement the project, provide technical and in kind support and are committed to phase out HCFC-22 upon successful completion of their project. They are willing to demonstrate the results and share the experience and lesson learnt with other supermarkets in both regions (Latin America and MENA countries) and enable replication by enterprises working in similar conditions.

PROPOSED TECHNOLOGY

CO₂ (R-744) Technology^{1,2}

CO₂ (R-744) is classified as “Natural Refrigerant” because it exists in the natural environment. Release to the atmosphere from refrigeration systems has a negligible effect compared to other CO₂ sources. In addition, the manufacturing process of CO₂ refrigerant can be based on CO₂ waste, which further minimizes the global warming impact of CO₂ refrigeration equipment through leaks.

As a refrigerant, CO₂ is a manufactured product that conforms to strict purity specifications. Its physical properties require special handling. The system pressures are much higher than in conventional systems, and all the components are designed accordingly.

High-pressure CO₂ systems were already developed end of the 19th century and used in many refrigeration applications. Starting from 1931, the entry into the market of the synthesized halogenated refrigerants marked the rapid and relentless decline in the use of carbon dioxide as a refrigerant. The reasons for this rapid decline lay in the comparative advantages of synthetic working fluids, like low energy efficiency and high cost of earlier CO₂ equipment, and also in the drastic reduction in refrigerating capacity of CO₂ equipment when ambient temperature increases.

¹ <http://www.centrogalileo.it/nuovaPA/Articoli%20tecnici/INGLESE%20CONVEGNO/CO2/Cavallini%20-%20Milano04CO2.pdf>

² http://www.emersonclimate.com/en-us/Market_Solutions/By_Solutions/CO2_solutions/ Documents/Commercial-CO2-Refrigeration-Systems-Guide-to-Subcritical-and-Transcritical-CO2-Applications.pdf



In the last 15 years, as environmental considerations gradually came to the forefront, CO₂ technology was “reinvented” as an environmental friendly solution in commercial refrigeration based on the low Global Warming Potential (GWP) of CO₂ and resulting in lower Total Equivalent Warming Impact (TEWI) compared with HFC Refrigerants. High investment costs were characteristic of early CO₂ projects, but these costs are now on a downward trend. Today, in A2 countries with moderate temperatures there is no difficulty in sourcing all the necessary equipment for CO₂ technology. However, in A5 countries this technology is still new, rarely used and the equipment and components are locally not readily available, and/or very expensive.

The first transcritical (TC) CO₂ supermarket refrigeration system was installed in Italy in 2005. By 2012, nearly 1,500 supermarkets in Europe have successfully implemented this system architecture. Denmark has completely phased out HFCs, and the United Kingdom and Germany are on track to do so in the next decade in this subsector. Since 2012, TC CO₂ systems have also been gaining popularity in Canada, with regional government organizations offering subsidies and incentives to supermarkets for projects replacing existing refrigeration systems with TC CO₂ systems. In the United States, the Hannaford Supermarket in Turner, was the first in the country to install a TC CO₂ system in July 2013. With the aim to raise awareness of this new technology, the U.S. Department of Energy commissioned a study, which has also proved not only the viability but also the superiority of transcritical systems³.

Quote: “The study shows relative parity between the energy consumption of the baseline and TC CO₂ stores, a reduction in climate impact, and potential additional operating cost benefits attributable to the use of a TC CO₂ system. This suggests that TC CO₂ supermarket refrigeration systems is a viable alternative to HFC-refrigerant-based systems on a case by case basis when considering climate impacts... Additionally, the system showed no issues with reliability or utility when compared to legacy HFC systems. The study also explored other considerations – such as the difficulty of retrofitting this technology and the limited availability of components and installation professionals.” Unquote

The cost of refrigerant itself is a fraction of the one of some specialty HFCs.

Different system concepts for cold and warm climates like indirect secondary systems; cascade or booster systems were developed.

Especially in cold climates the CO₂ systems can show better energy efficiency compared with HFC systems, because the temperature profile allow the subcritical operation with very high coefficient of performance.

In warm climates cascade systems using CO₂ in the low temperature stage and a low GWP refrigerant for the medium temperature could be a high efficient solution.

³ Case Study: Transcritical Carbon Dioxide Refrigeration Systems, January 2015, (http://energy.gov/sites/prod/files/2015/02/f19/Hannaford%20Study%20Report%201-22-2015_CLEAN.pdf)



Lately the parallel compressor system using single refrigerant shows a number of advantages and competes well in simplicity, climate impact and energy consumption with the cascade systems.

Furthermore, CO₂ is ideal for heat recovery and combine heating and cooling at the same time, which results in a significant reduction of the CO₂ emissions of the building.

The physical properties of CO₂ cause it to behave in a different way under the conditions needed to deal with the medium and low temperature refrigeration requirements. In particular, the pressure, and phase change behavior are very different to fluids previously chosen for vapor compression systems. These properties can offer significant advantages over traditional technologies, but in order to take advantage of this it is necessary to come to terms with those properties.

Tools like the “Right Balance Calculator” of Emerson Company can help to identify the best solution for the environment impact (TEWI), investment and energy cost.

Technical properties of R-744

Various criteria should be considered when selecting properties, safety, environmental impact, ease of use, and availability of components and expertise. R-744 meets the demand for a natural refrigerant with a low global warming impact, but presents challenges in both its application and handling.

TABLE 1. CHARACTERISTIC PROPERTIES OF CARBON DIOXIDE AND SOME OTHER TRADITIONAL REFRIGERANTS

Fluid	Critical Temperature [°C]	Critical Pressure [bar]	Saturation Pressure at -20°C, at +30°C [bar]		Volumetric Latent Heat at -20 °C [kJ/m ³]	Molecular Mass [kg/kmol]
CO ₂ (R-744)	31.06	73.84	19.67	72.05	14,592	44.01
R-22	96.15	49.90	2.453	11.92	2,371	86.47
R-134a	101.06	40.59	1.327	7.702	1,444	102.03
R-410A	71.36	49.03	4.007	18.89	3,756	72.59
NH ₃	132.25	113.33	1.901	11.672	2,131	17.03

Table 1 shows the physical properties of CO₂ when used as a working fluid in the traditional refrigeration processes. The main difference, as compared to traditional refrigerants such as R-22, is the very low value of the critical temperature, 31 °C for R-744. This temperature is around the maximum summer ambient temperature in countries with temperate climate. As a consequence, in the traditional vapor compression refrigerating cycle, the process of heat rejection to the environment does not usually imply condensation of the carbon dioxide working fluid, but a dense gas progressive cooling at a constant pressure higher than the critical pressure. At design conditions a CO₂ refrigerating machine therefore does not usually work with a condenser, but rather with a high-pressure gas cooler. The corresponding refrigerating cycle is called **transcritical**, as it takes place between two isobars, the former at



a pressure value lower than the critical one (evaporator), and the latter at a pressure above the critical one (gas cooler).

The **triple point** is the condition at which solid, liquid and gas co-exist.

The triple point occurs at 75.1 psia (5.18 bar) and -69.8°F (-56.6°C), below this point there is no liquid phase. At atmospheric pressure (14.7 psi or 1 bar), solid R-744 sublimates directly to a gas. Solid R-744 will have a surface temperature of -109.3°F (-78.5°C). If R-744 is at a pressure higher than the triple point and it reduces to a pressure below the triple point (for example to atmospheric pressure), it will deposit directly to solid. This can occur when charging an evacuated refrigeration system with liquid R-744 for example. Solid R-744 is also known as dry ice.

The **critical point** is the condition at which the liquid and gas densities are the same. Above this point distinct liquid and gas phases do not exist. The critical point occurs at 87.8°F (31.06°C), which is below typical system condensing temperatures for part or all of the year, depending on the climate. Above the critical point the refrigerant is a supercritical fluid. There is no phase change when heat is removed from a supercritical fluid while it is above the critical pressure and temperature.

The chart in Figure 1 shows the triple point and the critical point on a simplified phase diagram.

Figure 1. Phase Diagram of R-744

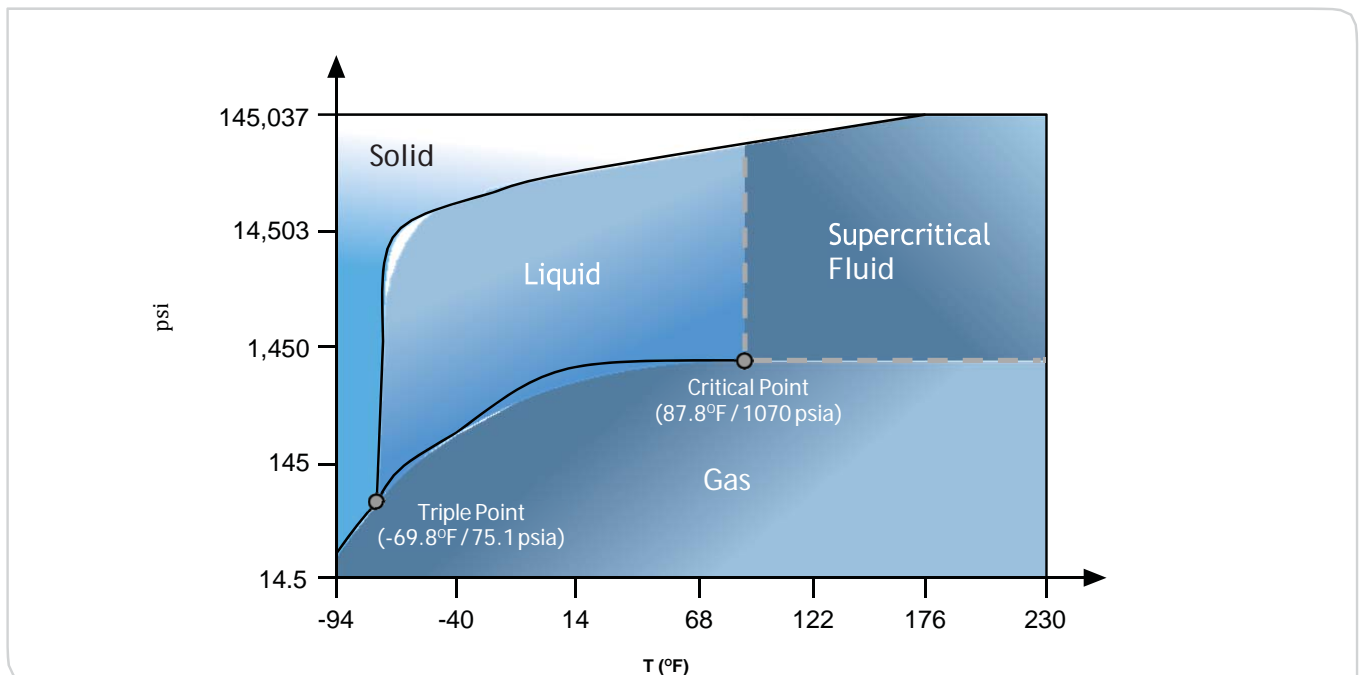



In a refrigeration system supercritical R-744 will not condense until the pressure has dropped below the critical pressure. No other commonly used refrigerant has such a low critical temperature so they always condense as heat is removed on the high side of the system.

The triple point of carbon dioxide is high and the critical point is low compared to other refrigerants.

TABLE 2. TECHNOLOGICAL PROPERTIES OF CO₂ AS REFRIGERANT

Criteria	How well does R744 meet the criteria?
Cooling capacity	Significantly higher volumetric capacity than conventional refrigerants
Efficiency	Efficiency depends on system type and ambient temperature
Operating conditions	Operating and standstill pressures significantly higher than for all other common retail refrigeration refrigerants
Environmental properties	Global Warming Potential (GWP) = 1, significantly lower than for commonly used HFCs
Availability of refrigerant	Varies globally but generally available
Availability of system components	Many components are different to those used on HFC retail systems, but these are now generally available
Availability of competent engineers and technicians	Varies globally but generally low; engineers must have a good understanding of basic refrigeration and good refrigeration practice and will require further training for R744
Cost	Refrigerant cost is lower than for HFCs, but system costs are generally higher
Safety	Low toxicity and non-flammable: high-pressures and associated hazards present additional challenges
Ease of use	High-pressure and low critical point drive the need for more complex systems
Availability of appropriate standards	Safety Standards ASHRAE 15 & 34 and ISO 5149 include R744
Composition	Single molecule, no temperature glide in subcritical operations
Suitability as a retrofit refrigerant	Not suitable due to higher pressures

A significant challenge with the application of CO₂ as refrigerant is the higher operating pressures compared to other commercial refrigerants.

- a. The chart in Figure 2 compares the pressure of R-744 with R-404A and R-134a. The saturation curve for R-744 does not extend beyond 87.8°F (31°C) because this is the critical point - above this condition there is no distinction between liquid and gas. Operation above this pressure is current practice in transcritical systems.
- b. R-744 systems operate subcritically when the condensing temperature is below 87.8°F (31 °C)

Annex I



DEMONSTRATION PROJECT IN THE REFRIGERATION ASSEMBLY SECTOR

- c. R-744 systems operate transcritically when the “gas cooler exit temperature” is above 87.8°F (31 °C) and the evaporating temperature is below 87.8°F (31 °C).

HFC systems always operate subcritically because the condensing temperature never exceeds the critical temperature (e.g., 214°F or 101 °C) in the case of R134a).



Figure 2. Pressure-Temperature Diagrams of Various Refrigerants

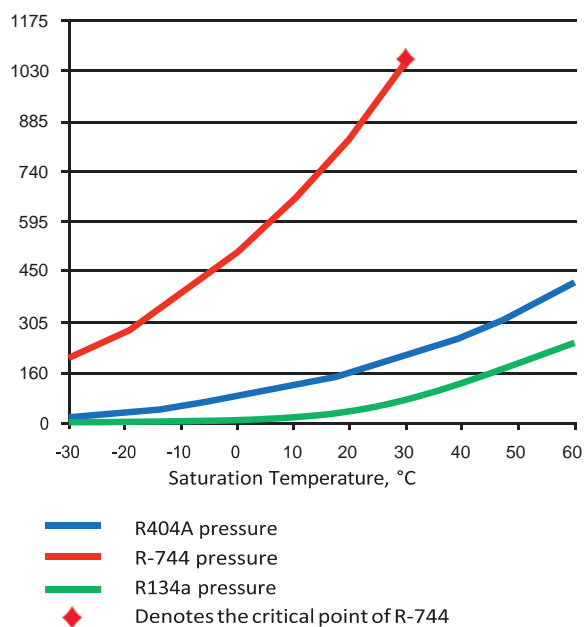

The high density of R-744 compared to HFCs results in the requirement for less compressor displacement. However the motor size would be similar since the work done is approximately the same.

Smaller pipe diameters are also a result of the higher density, especially on the suction side of the system.

The higher pressures of R-744 result in the need for all components to have a higher maximum pressure rating; the use of specialized high-pressure expansion valves made of high-grade steel, tested to upwards of 2,000 psi. Much of the system is to be built to more robust specifications than normally required, with stainless steel replacing copper for most rack components. These higher-grade specifications come with a high associated upfront cost premium, but also may reduce the operating and maintenance costs on a life-cycle basis due to decreased component failure.

The high discharge temperatures of R-744 (because of the high index of compression) result in the need for two-stage compression for LT systems that reject heat to ambient air. Transcritical CO₂ systems enable better use of heat recovery to augment space or water heating. A heat-reclaim system – a secondary loop mated to the compressor discharge line or gas cooler – is a feature installed in many TC CO₂ systems.

The low critical temperature of R-744 results in differences in system design and control.

Table 3 below shows the technical properties of CO₂ refrigerant.



TABLE 3. ADVANTAGES AND DISADVANTAGES OF R-744

Advantages	Disadvantages
------------	---------------



High refrigeration capacity due to high volumetric cooling capacity (e.g., it is approx. up to 5 times that of R-404A). This has a positive impact on compressor displacement and the sizing of heat exchangers and pipe work.

Lower pressure drops in pipe work and heat exchangers. Thus, the impact of long suction and liquid lines is less.

High heat transfer in evaporators and condensers due to the high- pressure and density. This will either allow lower temperature differences between the refrigerant and the air; therefore improving efficiency, or allow the use of smaller evaporators and condensers.

Tubing wall thickness may need to be increased to handle the higher pressures, so careful design is required to take advantage of the R-744 properties.

The pressure drop across an expansion valve is greater than with other refrigerants, so the minimum setting for head pressure control can be lower. This improves efficiency.

Lower compression ratios leading to higher compressor isentropic efficiency.

Non-corrosive with most materials. There are very few differences to the materials used in HFC systems.

Good miscibility with compressor lubricants for oil return. Polyolester type lubricants can continue to be used as with HFCs.

Low toxicity and non-flammable.

Negligible GWP so that, in the event of a leak, the direct impact on climate change is very low.

Inexpensive to produce and widely available, although the purity of the R-744 should be 99.99% for use in a refrigeration system with hermetic and semi-hermetic compressors, i.e., refrigerant grade.

High discharge temperatures due to the high index of compression. This provides good potential for heat reclaim. Note – the discharge temperature is excessively high in transcritical systems with a large difference between evaporating and heat rejection temperatures.

Stable molecule leading to a low potential for decomposition within the refrigeration system.

There is no impending legislation phasing down or phasing out R-744 so it can be viewed as a long-term refrigerant.

High operating and standstill pressures are more hazardous and increase the leak potential. Specially designed components are required.

Special compressors are required because of the higher refrigeration capacity (different motor / displacement combination).

R-744 systems are more complex – either cascade or transcritical. This leads to higher costs in components and installation.

Pipe working on-site potentially includes steel or stainless steel, the need for specially licensed welders, and different jointing techniques due to higher pressure and different materials.

The greater complexity also increases the probability of poor performance and reliability, particularly if commissioning is not done well.

For transcritical systems two-stage compression is required for frozen food applications because of the high discharge temperature of R-744.

R-744 transcritical systems are less suited for high ambient areas (e.g., Southeast Asia), where the system will always operate above the critical point, because of the inefficiency of transcritical operation.

R-744 is not controlled by any regulation such as the European Fluorinated Gas Regulation, so its use is not as carefully monitored as HFCs and leak detection is not as rigorous. However, the high- pressures make the system leak prone, and performance will suffer if the leak rate is high.

R-744 systems are very sensitive to water contamination and can form unusual compounds when there is a leak in a cascade heat exchanger.



Technological options for CO₂ Systems

In the retail sector R-744 being used mainly in the following types of system:

A. Transcritical systems

Systems are called transcritical when heat rejection takes place above the critical point of the refrigerant (for CO₂ ambient temperatures from 68°F to 77°F).

Figure 3. Single-stage Transcritical System

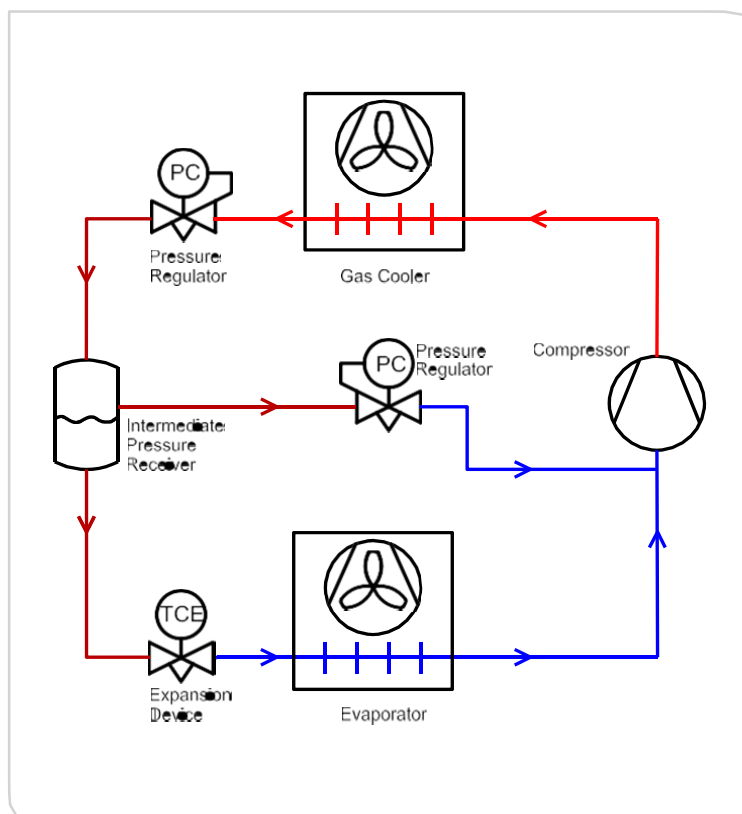

The diagram in Figure 3 is a **simple, single stage transcritical system**. The refrigerant discharged from the compressor flows into the gas cooler where heat is removed and the refrigerant temperature becomes cooler. The refrigerant is above the critical point, so it does not condense in this part of the system. The refrigerant then passes through the expansion device. The refrigerant condenses when its pressure drops below the critical point. Vapor then forms as the pressure reduces further to the evaporating pressure. The saturated refrigerant then flows into the evaporator where it evaporates and superheats. The superheated gas is drawn back into the compressor.

In this simple system:

- The temperature of the refrigerant at the exit of the gas cooler depends on the size of the gas cooler,



- The pressure of the refrigerant in the gas cooler depends on the quantity of refrigerant in the system and the ambient temperature.

The disadvantage of this type of system is that its capacity and efficiency vary significantly with ambient (air in) temperature and with the quantity of refrigerant in the system.

Booster systems: Systems with two temperature levels (e.g., -31°F and -4°F evaporating temperature) and with low-stage and medium stage compressors (see figure 4).

Two-stage compression is used for transcritical low temperature applications because the discharge temperature of R-744 is high and will potentially result in lubricant break down. The diagram in Figure 4 shows a simple two - stage booster or externally compounded system.

The refrigerant from the low temperature loads is drawn into the low-stage compressors. The discharge from these compressors goes into the suction of the high-stage compressors.

The refrigerant from the medium temperature (MT) loads is drawn into the suction of the high-stage compressors. The refrigerant from the receiver pressure-regulating valve is also drawn into the suction of the high-stage compressors. The flash gas from the receiver pressure-regulating valve, and the suction gas from the medium temperature loads provide some inter-stage cooling.



Figure 4. Transcritical Booster System

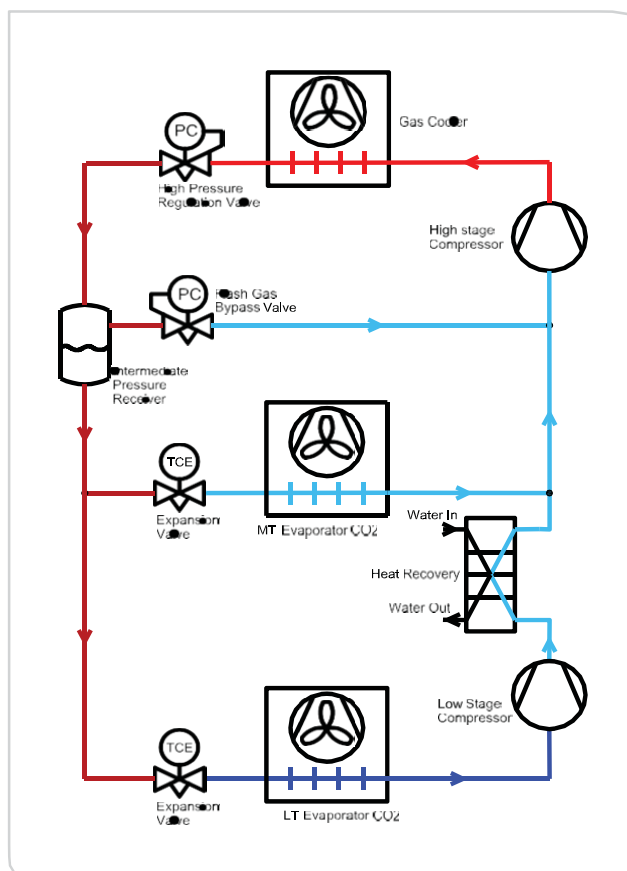

B. Cascade systems

R-744 is the low-stage refrigerant in a cascade system in which the R-744 is always subcritical. The heat rejected by the condensing R-744 is absorbed by the evaporating high-stage refrigerant. The high-stage system is usually a conventional system using HFC or HC, in which case this is termed hybrid cascade. In some systems R-744 is used in the high-stage as well as the low-stage. The R-744 in the low-stage is always subcritical, but in the high-stage will be transcritical at high ambient conditions.

In this case, as shown on Figure 5 the high-stage provides cooling for the medium temperature load as well as removing the heat from the condensing R-744 in the low-stage at the cascade heat exchanger. The high-stage refrigerant is usually an HFC or HC, in which case the cascade is a hybrid system. In some systems R-744 is used in the high-stage. It will be transcritical at ambient temperatures above 68°F to 77°F (20-25 °C).



Figure 5. Cascade System

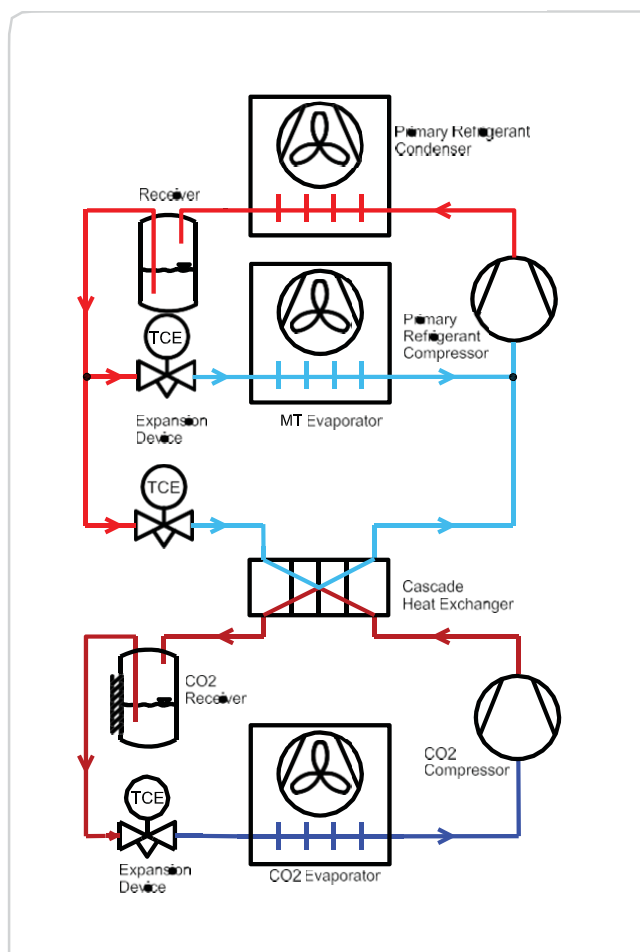

C. Secondary systems

R-744 is used as a secondary volatile fluid and is pumped through the heat exchangers (cooling load). The CO₂ is not completely evaporated, the gas is condensed by a chiller.

The diagram in figure 6 shows a simple secondary system. The high-stage system cools the liquid R-744 in the secondary circuit.

The R-744 is pumped around the load. It is volatile, so unlike a conventional secondary fluid such as glycol it does not remain as a liquid, instead it partially evaporates. It therefore has a significantly greater cooling capacity than other secondary fluids. This reduces the pump power required and the temperature difference needed at the heat exchanger. The R-744 would typically be cooled to 26.6°F (-3 °C) for the MT load, and to -13°F (-25 °C) for the LT load.



The high-stage system is a simple chiller type system, typically running on an HFC or HC refrigerant.

Figure 6. Secondary System

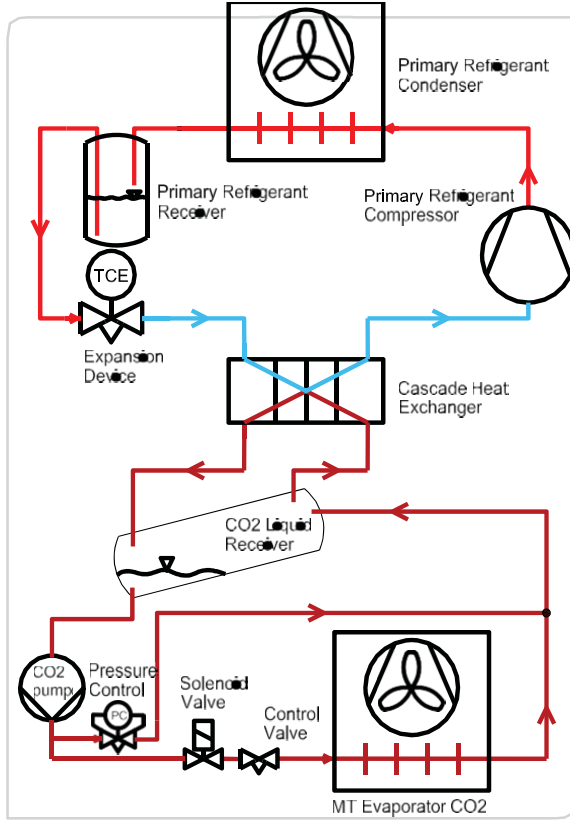



Table 4 below contains a comparison of the various transcritical R-744 systems.

TABLE 4. ADVANTAGES AND DISADVANTAGES OF THE VARIOUS SYSTEMS

System	Advantages	Disadvantages
Transcritical Booster	<ul style="list-style-type: none"> • One refrigerant • One system, lowest system costs • Better efficiency than HFC systems in mild climates 	<ul style="list-style-type: none"> • LT applications require two-stage compression • System faults in coupled systems affect MT and LT • High operation pressures • Lower efficiency as HFC systems in warm climates
Cascade	<ul style="list-style-type: none"> • Two simple systems • LT with low R744, the MT with a low GWP HFC refrigerant • Standard HFC components for medium and low temperature cycles • Better efficiency in warm climates 	<ul style="list-style-type: none"> • Two refrigerants although R-744 can be used in the high stage • Temperature difference in the cascade heat exchanger reduce the efficiency slightly for the LT cycle • System faults in coupled systems affect MT and LT
Secondary	<ul style="list-style-type: none"> • Using R-744 as a secondary fluid using the latent heat, very low pump power required • Simple chiller system for the high - stage with readily available components (separate chiller for LT and MT) • System works at constant pressure without any pressure pulsation • Option to combine LT and MT, pump circulation system for the MT using R-744 combined with a LT booster system • Chiller could use low GWP HFCs or HCs 	<ul style="list-style-type: none"> • Additional heat exchange and temperature difference slightly reduce the efficiency • R-744 pumps required • Pumps in this size are not readily available and are unfamiliar to many refrigeration engineers

D. Latest technological developments⁴

Booster systems have been the preferred option due to their relative simplicity and lower initial cost compared to cascade systems. There are already some 4,000 systems, mainly in supermarkets, which use the traditional booster system shown below. According to Danfoss there is a 100% market growth on year on year basis for these systems and it seems that in

⁴ Food Retail –Future Trends Natural Refrigerants, Danfoss



moderate climate countries booster system is now the market standard. The trend is now to move the market towards warmer regions.

However, at higher ambient temperatures the inherent properties of R-744 lead to loss of efficiency and elevated equipment costs. The efficiency of systems with CO₂ depends more on the application and the climate than with other refrigerants. For all refrigerants there is a decline in system efficiency with increasing condensing temperatures, and CO₂ is among the refrigerants with the steepest drop. The good thermo-physical properties of CO₂ can compensate to some extent, but there is a limit.

The problem with transcritical CO₂ systems in warm climate is not that they will not work, but more that there is a significant loss of capacity and efficiency.

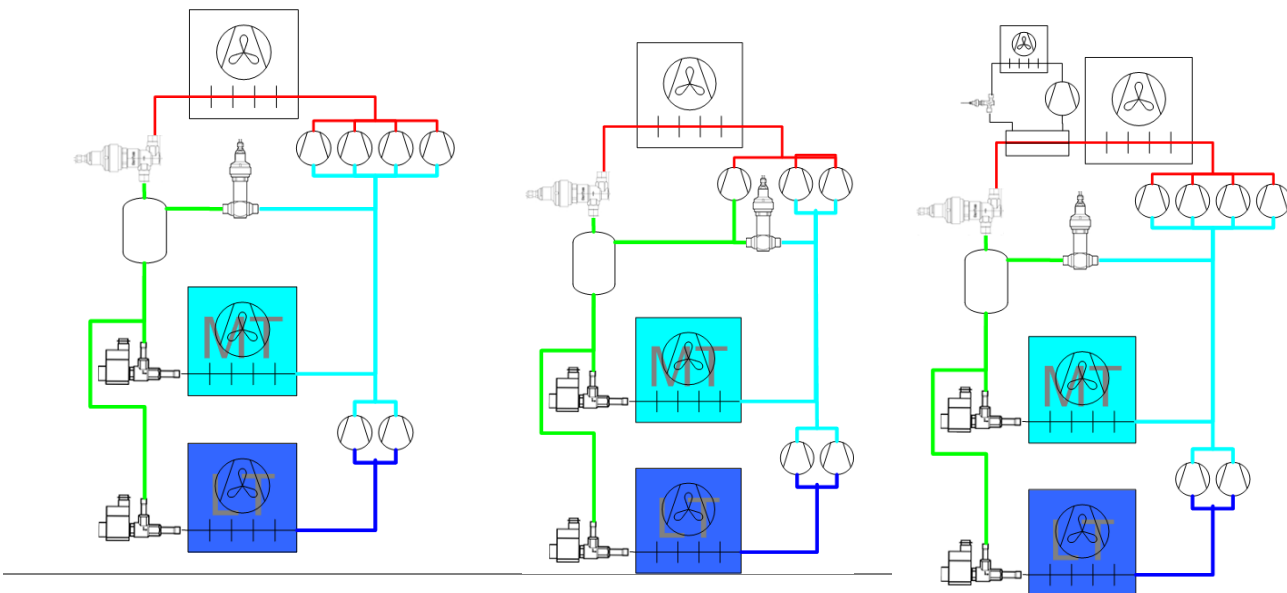

Figure 7 Traditional Booster System; Booster System with Parallel, and Booster System with Parallel Compression and Subcooling Compression.

In cold climates like the Nordic climate we see 10% lower energy consumption, but going to warm climates like Asia, South Europe, Southern part of North America, Latin America and Africa is a challenge for CO₂ systems. The extra cost of compressors and loss of efficiency could make the technology less attractive.

Lately new innovations to the traditional booster system came to fruition.

- i. The second system in Figure 7 shows that the traditional booster system is complemented with a compressor, which compresses the flash gas from the refrigerant valve that regulates the pressure in the liquid receiver (flash tank) and



associated pipe work. The advantages of this solution are:

- a. Solution is mature and well proven,
 - b. 5-10% energy improvement in warm climates,
 - c. Approximately 25% saving on installed capacity,
 - d. Can be combined with other features to enhance the system.
- ii. The third system shown on Figure 7 includes an additional heat exchanger – so called subcooler. The advantages of this solution are:
- a. Solution is ready
 - b. 5-10% energy improvement in warm climates
 - c. Up to 50% saving on compressor capacity, but the capacity is needed on the auxiliary cooling unit.

In warm climates, when the system works in transcritical cycle the amount of flash gas inside the liquid receiver increases.

In a transcritical system the receiver pressure is controlled by expanding the vapor released through connection of a by-pass Flash Valve to the medium temperature suction header.

The parallel compressor in the system the result is a better performance due to a reduction in the compression work between the intermediate pressure in the receiver and the common discharge pressure.

For example under external temperature of 40 °C, the system develops increased amount of flash gas. Medium temperature compressors will work with a COP of 1.34 and the parallel compressor will have a COP=2. Without parallel compressor all the flash gas will pass through the medium temperature compressors.

Other component added to the system to save energy is an external subcooler installed before the transcritical valve. It is a plate heat exchanger, which works with a dedicated chiller. This subcooler reduces the gas's enthalpy, and reduces the amount of flash gas.

- iii. The latest development is the so-called Ejector Compression System. This idea is under development and has not yet come out on the market.
- iv. Further energy savings can be achieved by utilization of waste heat developed in the refrigeration system. Such integrated systems combining the energy requirements of cooling, heating and air-conditioning are extremely attractive under cool or moderate climate condition, but could bring benefits also in warmer countries e.g. to produce hot water. The applicability is to be evaluated based on the cost-benefit ratio.



Figure 7 Integrated System for Heat Recovery

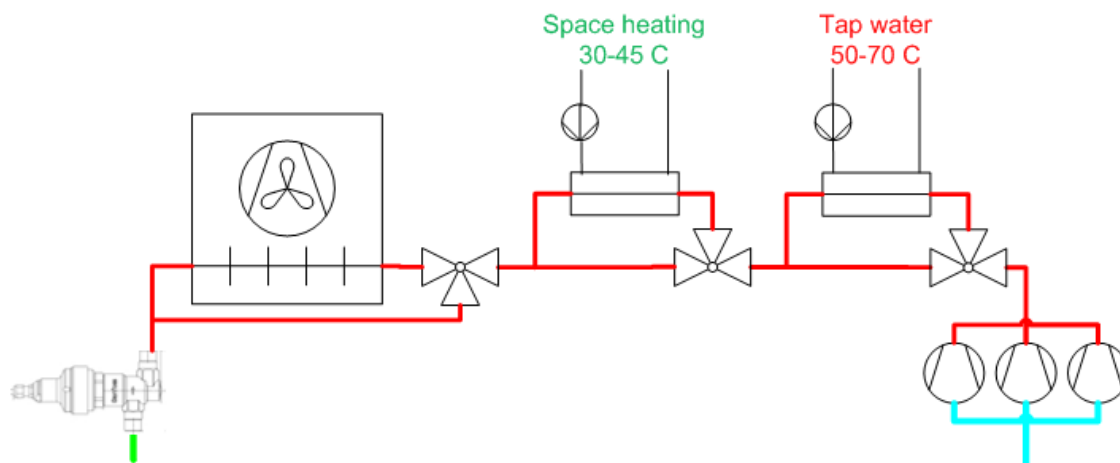

Whichever transcritical R-744 configuration is selected, the transition from a synthetic working fluid to carbon dioxide requires replacement of effectively all system components, including specialized compressors (designed for the thermo-physical properties of CO₂), a gas cooler that works differently from conventional heat exchangers, and compatible display cases and piping.

Therefore, implementation of this technology is only practical for a new installation or a major renovation. It does not lend itself to a low-downtime retrofit in a store that is already fitted with a HCFC-based system.

Technology selection

After thorough review of the available technological options suitable for the warm climate conditions at the beneficiary supermarkets the project counterparts in cooperation with the government and UNIDO experts decided to introduce:

Transcritical CO₂ Booster System with Parallel Compression where the refrigerant in both stages (medium and low temperature or lower and high pressure circuits) is CO₂ (no secondary fluid) and Sub-cooling with R-410A (Option 1) or HC-290 (Option 2). However, the charge in the sub-cooling is quite small compared to the charge of CO₂ (210 kg): HC-290 amounts to 3.5 kg; R-410A amounts to 5.8 kg.

In the subproject for Argentina HC-290 is proposed, since the allocation of the machine room is such that it can accommodate equipment using flammable refrigerant. In the case of Tunisia there is no room for a dedicated safe area for this chiller. So, instead of hydrocarbon refrigerant HFC-410A is proposed. The climate impact of the HFC refrigerant of this sub-cooler is accounted for in the corresponding calculations.

The new equipment will have built-in energy monitoring apparatus, so the post-project data can be compared with the pre-project ones. Regarding the latter, once the project is approved counterparts will discuss on how to monitor and record the current energy consumption of the refrigeration equipment.



There are several companies producing the required equipment for the conversion e.g. EPTA, Carrier etc. In the case of Argentina, EPTA has local facilities which can supply some and service all the equipment. Nevertheless, in line with UNIDO's financial rules and regulations there will be an international bidding process. Necessity for local technical support by the supplier will be strongly emphasized in the bidding process.

Any technology developments during implementation may be taken into account; e.g. ejectors.

PROJECT BUDGET

The itemized budgets of cost of both sub-projects are shown in the respective Sub-Project Documents. The overall project budget is shown in the following table:

**TABLE 5. TOTAL BUDGET**

Item	[USD]
TOTAL COST OF SUB-PROJECT 1: Argentina	527,169
TOTAL COST OF SUB-PROJECT 2: Tunisia	319,131
PROJECT TOTAL	846,300
Support cost, 7%	59,241
GRAND-TOTAL	905,541

Co-funding

The counterparts already agreed to bear substantial cost related to the following items:

1. construction work,
2. decommissioning and destruction of the HCFC-22 equipment,
3. rearrangement of the supermarket,
4. closure of the supermarket for the time of conversion,
5. training of staff,
6. replacement work in the cold rooms, where only the evaporators are budgeted to the project,
7. in the initial period after start up, there will be various technical difficulties, which will have to be solved by extra support from the technical centre of the chain or by the supplier's service engineers,
8. and cost sharing for the replacement of refrigeration cabinets.



IMPLEMENTATION SCHEDULE

The two projects will be implemented concurrently. The schedule of implementation of both projects is shown below.

TABLE 6. IMPLEMENTATION SCHEDULE

Activity	Timeframe after approval									
	Year 1				Year 2				Year 3	
	I	II	III	IV	I	II	III	IV	I	II
Agreement with project beneficiaries signed										
TOR prepared, bidding started										
Contract for equipment signed										
Equipment manufactured and delivered to project site										
Equipment installed, commissioned, started up										
Dissemination of information, Demonstration workshop										
Project closure										



SUB-PROJECT 1: ARGENTINA

Recipient Company background

For the implementation of the demonstration project the Government in close cooperation with La Anonima selected a supermarket in the town of Lincoln.

La Anonima (Sociedad Anonima Importadora y Exportadora de la Patagonia in short La Anonima) was founded more than 100 years ago by two pioneers to populate Patagonia.

In 1908 Mr. Jose Mendez and his son-in-law Mauricio Braun merged their companies and open a general store, huge sheep farms (estancias). They also set out to import various goods and export domestic produce like wool and leather. Thus, they established a marine shipping company in order to be able to ship goods from and to US and Europe,

During 1942 they brought their company on the stock exchange. During the middle of 1960s, due to the difficult financial situation the company decided to close the shipping business of the company and sold some of the large estates. They concentrated more and more on consumer goods trade and converted the general stores into supermarket format.

In 1979 the Braun Family bought up all the stocks and started to expand their supermarket business.

In 1997, 57 new branches and the first hypermarket were opened in Neuquén state.

Today La Anonima is branch leader in Patagonia, the fourth in Argentina and second largest supermarket in Argentina among the chains owned by domestic capital.

La Anonima also established regional distribution centres to warrant constant availability of stable variety of goods in all their supermarkets all over the country and to avoid problems related to the long distances from Buenos Aires.

Today, the company owns 161 branches, 10 distribution centres plus 2 slaughterhouses and meat processing plants

La Anonima supermarkets aim to serve a wide spectrum of clients offering from standard to sophisticated goods.

La Anonima has high reputation due to the quality and selection of goods and services as well as very competitive prices.

The company is also focused also to promote communal activities.

A. Location of the Supermarket⁵

The supermarket selected for the project is located in Lincoln. Lincoln is a city in the province of Buenos Aires in Argentina. It is the capital of the district of Lincoln (Partido de Lincoln). The town was founded in 1865 and named as a tribute to the 16th U.S. president Abraham Lincoln who was assassinated in the same year.

Lincoln's economy is dominated by agriculture. The main crops are wheat, maize, soy and sunflowers. The district is home to around 500,000 cows and is responsible for 10% of Argentina's honey production.

⁵ https://es.wikipedia.org/wiki/Lincoln_%28Argentina%29



The population of District of Lincoln, Argentina is 41,808 according to the GeoNames geographical database (2015) has approx. 28,500 inhabitants. Lincoln is located at -34.8665 [latitude in decimal degrees], -61.5302 [longitude in decimal degrees] at an altitude of 76 meters.

The average elevation of Lincoln, Argentina is 92 meters.

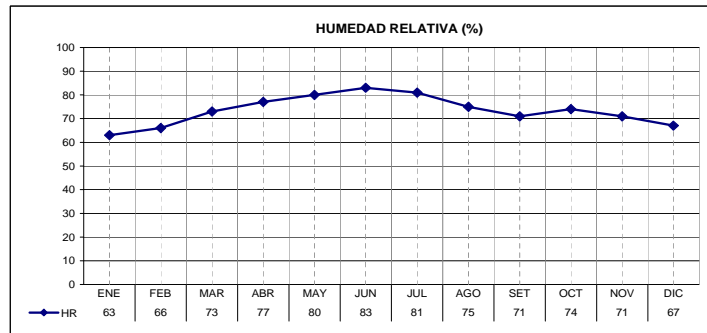
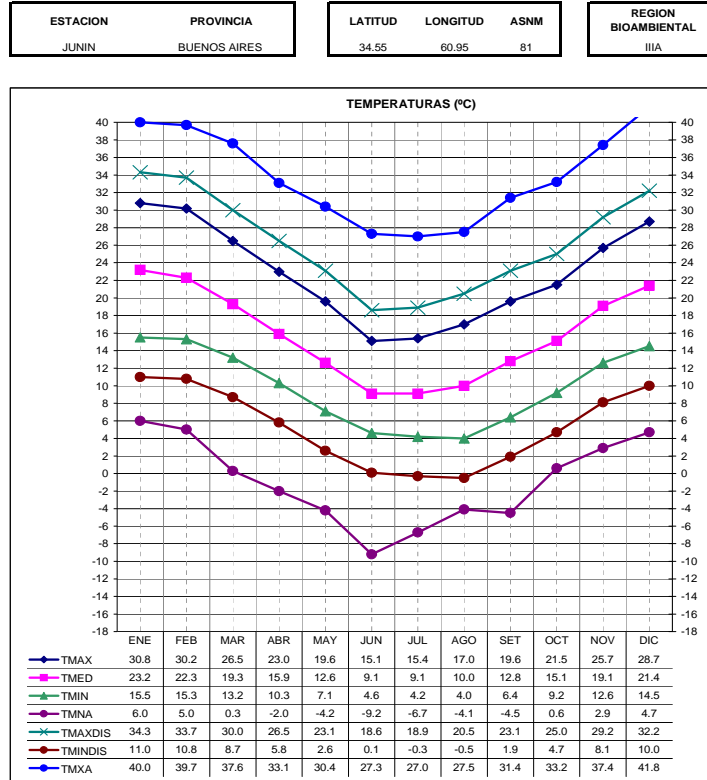

Figure 8 Temperature and humidity in Junin (Lincoln)

**B. GENERAL INFORMATION OF THE STORE****TABLE 7. GENERAL INFORMATION OF THE SUPERMARKET IN LINCOLN**

Address	Calle Ituzainó 146, Lincoln, Provincia B.A.
GPS coordinates	Latitude: -34.8637778 (34° 51' 49.6" S) Longitude: -61.528350 (61° 31' 42.062" W)
Type of store	Supermarket
Sales area	1,100 m ²
Start-up	Opened in August 2000 in an existing building of a former sport centre

Picture 10 depicts the layout of the supermarket with the location of the refrigerated and frozen food sections and the roof with the machine room.

DX system with R-22 refrigerant is used for the central refrigeration system.

For the refrigeration system power consumption the monthly invoices of the power supplier for the year 2015 are available and could be presented, if required.

Photographs of all the machinery (condensers, refrigeration systems, cold storages, walk-in freezers, cabinets, display cases and aisles) and its nameplates were taken wherever possible. The most representative ones are included in this project document.

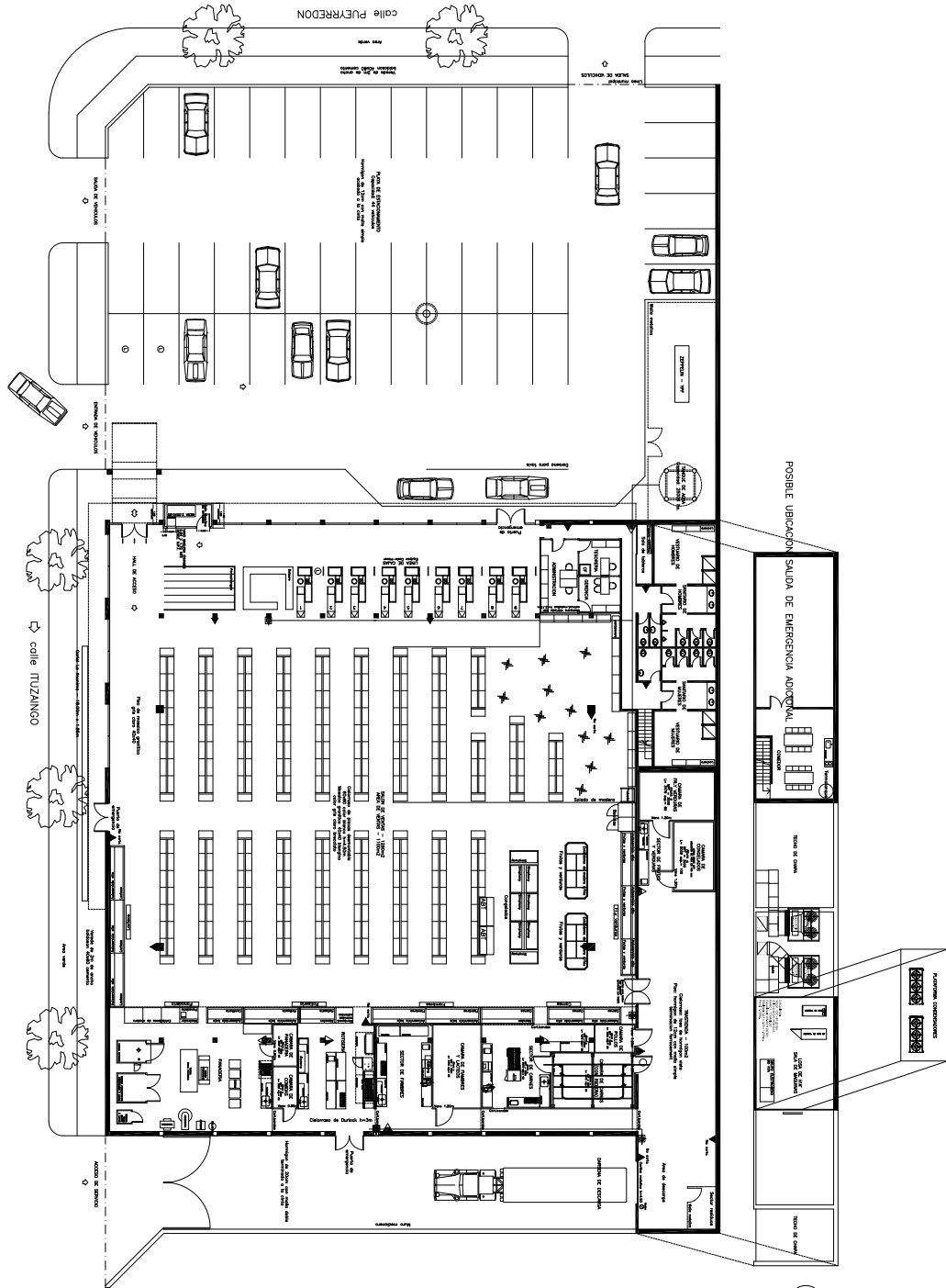

Figure 10 Layout of La Anonima, Lincoln

C. Overall description of baseline equipment



Figure 11 La Anonima Lincoln entrance

The supermarket has two central refrigeration systems:

1. Low temperature
2. Medium temperature

The refrigerant used in the central systems is **HCFC-22**.

Furthermore there are a number of self-contained freezer units (islands and upright reach-in cabinets). These work with **R-404A**.

The machine room.



Figure 12 Machine room

It has a total area of 20 m². It is located on the roof of the supermarket. The area occupied by refrigeration facilities is approx. 8 m².

The machine room contains:

1. **Low temperature circuit (BT#3):** compressor (one), oil separator, accumulator, controls and condenser for the central system
2. **Medium temperature circuit:** 1 pack of three compressors together with the oil separator, accumulator and controls.
3. Emergency generator



Figure 13 Medium temperature compressor pack (3 compressors)



Figure 14 Low temperature compressor, condenser, receiver, oil separator



Annex II

PROJECT COVER SHEET

PROJECT TYPE TITLE	Demonstration Project on Refrigerant Quality, Containment and Introduction of Low GWP Alternatives	
COUNTRY NAME	Global: Macedonia, Egypt, Mexico, Tanzania as lead country for selected East African countries (Eritrea, Kenya, Uganda, Zambia), and Grenada as lead country for selected Caribbean countries (Bahamas, St. Lucia, St. Vincent and the Grenadines, Suriname)	
LEAD IMPLEMENTING AGENCY	UNIDO	
COOPERATING IMPLEMENTING AGENCY	UNEP (Egypt and East Africa)	
NATIONAL COUNTERPART	National Ozone Units	
SECTOR	Refrigeration Service Sector	
SUB-SECTOR	Refrigeration and air-conditioning	
PROJECT STAKEHOLDERS	The Ozone Units, RAC sector and refrigeration servicing sector enterprises and technicians, local authorities and decision makers, industrial associations, training institutions etc. of the respective countries	
PROJECT COSTS [USD]	Macedonia	300,000
	Egypt	150,000
	Mexico	225,100
	Caribbean region	220,000
	East African region	210,000
	Total	1,105,100
MLF REQUESTED FUNDING [USD]	1,105,100	
UNIDO FUNDING ALLOCATION [USD]	1,010,100	
UNIDO SUPPORT COSTS @ 7% [USD]	70,707	
UNEP FUNDING ALLOCATION [USD]	95,000	
UNEP SUPPORT COSTS @ 13% [USD]	12,350	
TOTAL PROJECT COSTS [USD]	1,188,157	
PROJECT DURATION	18 & 24 Months	

PROJECT SUMMARY

The Executive Committee authorized UNIDO to prepare a global concept for the servicing sector targeting the containment of refrigerants and the introduction of low GWP alternatives in the refrigeration and air-conditioning (RAC) sector in selected A5 countries. The objective of the demonstration project is reduction of ozone depletion and global warming impact of the refrigeration and air-conditioning sector in A5 countries. The present demonstration project contains five subprojects:

1. Caribbean region (the Bahamas, Grenada, St. Lucia, St. Vincent and the Grenadines, Suriname): Safe handling of low-GWP flammable refrigerants
2. East African region (Eritrea, Kenya, Uganda, Tanzania, Zambia): Standards and Market Availability of Quality Refrigerants



Demonstration Project on Refrigerant Quality, Containment and Introduction of Low GWP Alternatives

3. Egypt: Refrigerant Containment and Refrigerant Leakage Prevention– based on REAL Zero Initiative
4. Macedonia. Holistic approach for the improvement of the level of refrigeration servicing sector
5. Mexico: Innovative Scheme for Minimization of Refrigerant Wastes and Safe Management of Recovered Refrigerants

The general background and an overarching strategy of refrigerant management are contained in the first part of the document. In line with requests of the target countries and the decision of the ExCom the first part of the document targets three groups of issues a) refrigerant quality, b) refrigerant containment, and c) facilitation of introduction of low GWP alternatives. The subprojects attached to this first part address issues relevant to the specific needs of the submitting countries and regions. The subprojects contain the country/region specific activities, beneficiaries and target groups, expected outcomes and their sustainability, as well as the implementation schedule and budgets.

The sub-projects also describe the relevance, demonstration value of the proposal as well as the strategy of dissemination of results and lessons learnt. Through these actions interested A5 countries can replicate the pilot projects.



DEMONSTRATION PROJECT

REFRIGERANT QUALITY, CONTAINMENT AND INTRODUCTION OF LOW GWP ALTERNATIVES

LEAD IMPLEMENTING AGENCY: UNIDO
COOPERATING IMPLEMENTING AGENCY: UNEP

Prepared by Team of UNIDO project managers in close cooperation with national experts, Ozone Officers of target countries and UNEP.

Technical advisor: Mr. Tamas Grof

14 March 2016



Table of Contents

BACKGROUND	5
ISSUES AND CHALLENGES	6
A. REFRIGERANT QUALITY	6
B. CONTAINMENT AND REFRIGERANT LEAKAGE PREVENTION	8
C. INTRODUCTION OF LOW GWP ALTERNATIVES	8
PROPOSED SOLUTIONS	14
A. IMPROVEMENT OF REFRIGERANT QUALITY	14
B. CONTAINMENT AND REFRIGERANT LEAKAGE PREVENTION	15
C. INTRODUCTION OF LOW GWP ALTERNATIVES	19
IMPLEMENTATION STRATEGY	20
PROJECT BUDGET	21



BACKGROUND

UNIDO submitted three proposals for the preparation of demonstration projects in Egypt, East Africa (Kenya, Tanzania, Uganda and Zambia), and the Caribbean region (the Bahamas, Grenada, St. Lucia, St. Vincent and the Grenadines, Suriname). Given the similarities, the Executive Committee requested UNIDO to merge the proposals into *one global concept* targeting the containment of refrigerants and the introduction of low GWP alternatives in the refrigeration and air-conditioning (RAC) sector in the selected A5 countries.

The Executive Committee of the Multilateral Fund for the Implementation of the Montreal Protocol (MLF) authorized UNIDO to prepare a global concept targeting the containment of refrigerants and the introduction of low GWP alternatives in the refrigeration and air-conditioning (RAC) sector in selected A5 countries. The demonstration project should result in reduction of ozone depletion and global warming impact of the refrigeration and air-conditioning sector of A5 countries.

The implementation of the earlier RMPs, NPPs and current HPMPs of the target countries revealed that the stakeholders of the refrigeration service sector are facing various inherent problems related to the quality of refrigerants available on the market. These obstacles are hindering provision of service works on consistent quality level. The demonstration project was initiated to find resolution for these issues.

As a first step after approval of the preparatory assistance funds, UNIDO decided to convene an Expert Group Meeting of recognized experts with extensive experience in the field of refrigeration industry and implementation of the Montreal and the Kyoto Protocols in Article 2 (industrialized) and Article 5 (developing) countries. The aim of the Meeting was to discuss and provide inputs for the formulation of a demonstration project focusing on two areas:

- a) More efficient operation of equipment through general improvement of quality of refrigerants entering the domestic market and leakage reduction;
- b) Facilitation of the introduction of low GWP alternatives.

The Expert Group Meeting took place at UNIDO's Headquarters in Vienna on 6-10 August 2015. The high-level experienced experts came from various A5 and A2 countries

The major findings and recommendation of the Expert Group Meeting were used for the preparation of the project document.

The members of the expert group meeting identified reclamation and reuse in the service sector as key challenge for developing countries. For this reason, UNIDO, taking into consideration its experience in the developing countries, proposed the involvement of Macedonia and Mexico, both of which have demonstrated good results in recovery, collection and to a lesser extent in reuse. Both countries have shown great interest in participating in the demonstration project. Furthermore, one more request was received from Eritrea for its involvement in the East African proposal.



ISSUES AND CHALLENGES

A. Refrigerant Quality

As communicated by the potential recipients of the project and also experienced by some of the participants of the Meeting the quality of refrigerants on the market of many developing countries is unstable and in many cases unreliable.

The main problems and challenges identified are:

- a) Mixed refrigerants on the market;
- b) Fake refrigerants, i.e. substances sold as refrigerant, but not in conformity with the requirements and specification related to any classified standard refrigerant;
- c) Improper drop-ins – i.e. some refrigerants sold as drop-ins but cannot fulfill the technical requirements and perform the task required;
- d) Incorrect labeling – by mistake or on purpose;

The above discrepancies are caused and driven by economic interests, deficiencies of the regulatory framework, insufficient and/or inefficient control mechanism, and lack of technical knowledge.

Economic drivers

It is a general phenomenon that the economic value of refrigerants is not appreciated by the equipment owners – the perception of treating “refrigerant as a consumable” prevails, since the value of refrigerant and the costs associated with the top up of refrigeration equipment in most cases represents a fraction of the running cost of the main business of the owner. In this scenario there is no economic benefit in collecting and purification of refrigerants and even if the refrigerant is collected it cannot be disposed economically.

Small-scale refrigeration service entities try to minimize their cost through purchases of non-standard, off-specification and very cheap refrigerants unaware or without concern of the consequences.

Deficiencies in the regulatory framework

The types of refrigerants entering the market are not controlled. In some countries along with the standard and internationally approved (ISO, ASHRAE registered) refrigerants produced by trustworthy firms, other non-reliable, low quality products from less reputable producers/suppliers could enter the market.

Similarly, newly developed refrigerants can be imported without any classification of the local technical bodies and/or technical support from the supplier

In the target countries there is no requirement for certification of refrigerant wholesalers and distributors as prerequisite of handling of refrigerants.

Similarly there is no licensing requirement to purchase refrigerant on the domestic market and anyone even without any special training can buy and handle refrigerant.



Insufficient and inefficient control mechanism

Sometimes lack of tools and manpower at customs are hindering proper import control. In some countries, the quality and quantity of refrigerant identifiers available at the customs do not correspond to the tasks required from them. The fluctuation and rotation of customs officials require training of the new staff. Customs officers should check all types of real and “fake” refrigerants;

There is no government control of refrigerants sold on the domestic market. In the target countries the import of ODS is regulated by a license and quota system. However, there are no regulations similar to F-Gas regulations of the EU, which would regulate and control the domestic sale and purchase, the handling and recording the use of refrigerants as well as performing various tasks related to refrigerant handling, and the installation and servicing of refrigeration and air-conditioning equipment-

The certification of service technicians is not regulated on national level. Moreover in many countries there are no all-inclusive refrigeration service technician associations to represent the interest of the trade and voluntarily regulate/control the activities of technicians.

Lack of technical knowledge and understanding of refrigerants

Insufficient knowledge and skills related to refrigerant handling, use and management is experienced at various levels.

In many cases authorities are lacking sufficient information on the technicalities of the sector to address important issues when formulating regulations. Traders should also possess technical knowledge to properly select suppliers and products when purchasing refrigerants for the domestic markets. The same way the distributors should have appropriate technical skills to advise their clients on proper selection and use of refrigerants.

Many service technicians are not suitably trained on selection, handling, charging and recovering refrigerants. Operators and owners of equipment are lacking understanding to control leakage and appreciate the value of refrigerants as well as the impact of refrigerant releases.

In such circumstances the sale and use of improper refrigerants is highly probable. Application of improper working fluids in cooling and heating appliances and equipment may create:

- a) Safety hazards;
- b) Inefficient operation of refrigeration and cooling equipment (reduced cooling capacity, increased energy consumption);
- c) Increased frequency of repairs;
- d) Increased refrigerant leaks due to seal failures;
- e) Reduced lifetime of equipment;
- f) Increased environmental impact (ODP, GWP, VOC emissions etc.);



- g) Dangers to humans and other living organisms;
- h) Serious financial implications of all above items.

B. Containment and Refrigerant Leakage Prevention

In many countries preventive maintenance and containment control of refrigeration and air-conditioning equipment is usually rare and/or of low technical level, so leak rates are inherently high.

Furthermore, there is a very low demand for recovered and/or reclaimed refrigerant because the difference between the price of the virgin refrigerant and the cost of reclaimed ones is insignificant or negative. The high cost of the second-hand refrigerant is caused by the high processing and transportation costs of waste refrigerants since in many countries there are no or very few refrigerant waste collection centers properly equipped to store, select and collect waste refrigerants to treat or destroy them in economically viable batches. Thus, the demand for waste refrigerant is marginal; recovery and purification is not an attractive proposition for the owners and operators of refrigeration equipment. In many countries access to refrigerant destruction facilities is limited; cross border transport of hazardous wastes is complicated and expensive especially for smaller quantities.

In addition end users do not value their refrigerant stock as part of their asset base, which needs to be protected. In view of the lack of financial incentive and awareness leak rates are high and refrigerants in many cases are vented. The combined environmental and financial impact of refrigerant leakage is significant.

Another reason for the high leakage and venting rates is the inadequate theoretical knowledge, and practical skills of technicians, operators, and equipment owners. Some of them lack service tools, leak detecting equipment and techniques and use improper servicing techniques: leak detection, repair, sealing/ brazing.

The low level of awareness about the cost, technical and environmental impact of poor containment results in:

- a) Safety hazards;
- b) Inefficient operation of refrigeration and cooling equipment (reduced cooling capacity, increased energy consumption);
- c) Reduced life time of equipment;
- d) Increased environmental impact (ODP, GWP, toxicity).

C. Introduction of low GWP alternatives

In industrialized countries the replacement HCFCs with alternative refrigerants has started way back and in a short time use of HCFCs will be banned. At the same time the HFCs, which earlier had been the common replacement alternatives to HCFCs are being phased out in the industrialized countries.

In the case of A5 countries ban of HCFCs will follow the schedule below:



Phase-out schedule for HCFCs in Article 5 countries	
Step	Year
Baseline	2009-2010
Freeze	2013
10 % reduction	2015
35 % reduction	2020
67.5 % reduction	2025
97.5 % reduction	2030
Average 2.5 % for servicing tail only	2030-2039
100 % phase-out	2040

The above schedule means that substantial amount of HCFCs will be with us for some 15 years more.

At the same time the climate change issues are coming to the forefront and negotiations are ongoing under the Montreal Protocol for the gradual phase out of HFC-s with the A5 countries as well.

The above trends have serious implications on A5 countries and that has to be taken into consideration when formulating an HCFC refrigerant phase out strategy:

- a) Many industrialized countries will gradually stop the production of appliances and equipment charged with high GWP HFCs;
- b) In the foreseeable future A2 governments will enforce replacement of high GWP HFCs in commercial and industrial refrigeration equipment in their respective countries;
- c) Shortly, no HCFC containing equipment and appliances will be exported to A5 countries from industrialized countries;
- d) In order to facilitate replacement of high GWP refrigerants the new F-gas Regulation refers to the charge in terms of CO₂ equivalents rather than kilograms of F-gases. This would give preference to low-GWP alternatives including HFC-32; however there are motions to ban substances with GWP above 150, i.e. HFC-32 as well. The [MAC Directive](#) of the EU prohibits the use of F-gases with a GWP of more than 150 in new types of cars and vans introduced from 2011, and in all new cars and vans produced from 2017.

Figure 1 HFC Phase-out targets in the EU

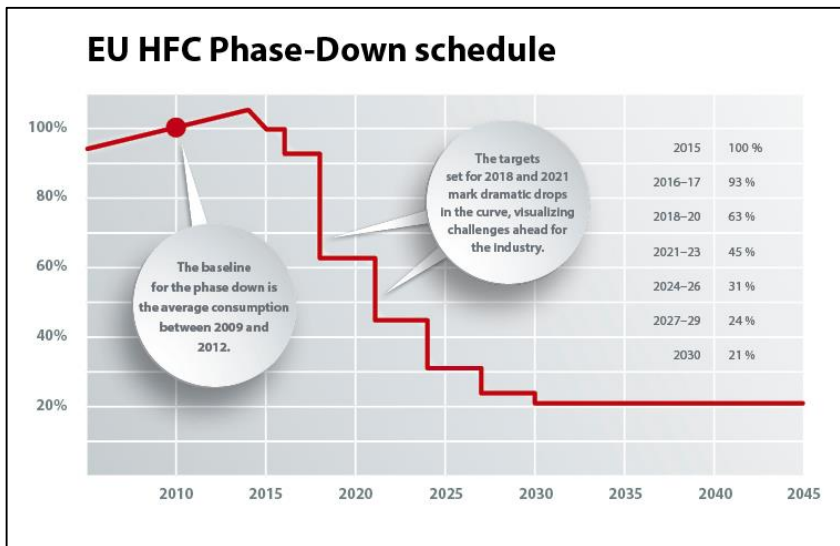
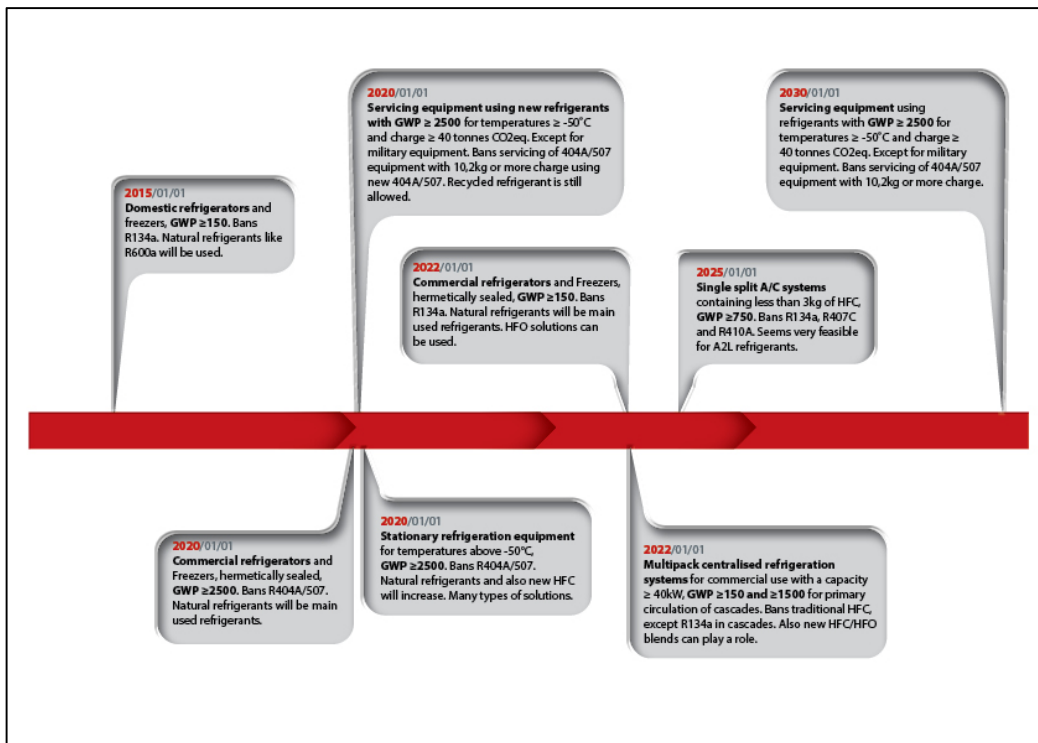

Figure 2 Current EU regulations related to specific refrigerants



Source: <http://refrigerants.danfoss.com/hfc/>

The EU F-Gas Regulation calculates the charge based on the Global Warming. The following limitations apply:



Refrigerant	GWP	Charge limits in t CO ₂ -equiv.				
		5	40	50	500	1,000
		Conversion of charge limits in kg				
R134a	1,430	3.50	27.97	34.97	349.65	699.30
R32	675	7.41	59.26	74.07	740.74	1,481.48
R404A	3,922	1.27	10.20	12.75	127.49	254.97
R407C	1,774	2.82	22.55	28.18	281.85	563.70
R410A	2,088	2.39	19.16	23.95	239.46	478.93
R422D	2,729	1.83	14.66	18.32	183.22	366.43
R507A	3,985	1.25	10.04	12.55	125.47	250.94

Since some new alternatives are coming to the fore replacing high GWP refrigerants, theoretically it would be possible for many A5 countries to partially leapfrog the HCFC-HFC conversion stage and introduce long term low-GWP alternatives;

At the current stage of implementation of HCFC Phase-out Management Plans (HPMP) A5 countries should as first priority prepare themselves for adoption and absorption of new technologies, build up skills to install, operate and service appliances and equipment charged with the latest new generation alternatives;

Experts agree that in the medium term, i.e. 5 to 10 years the following alternatives will be widespread in A5 countries:

List of refrigerants expected to spread in A-5 countries in the next 5-10 years

Refrigerant	Application
R-600a	Refrigeration, domestic, light commercial
R-290	Air-conditioning, self-contained commercial refrigeration
CO₂	Bottle coolers, vending machines, commercial refrigeration (food retail (supermarkets and food stores), food production and storage (also in cascade with NH ₃), car air-conditioning
NH₃	Industrial (chiller, central plant food production and storage)
HFO-1234yf	Motor vehicle air-conditioning
HFC-32	Air-conditioning
HFO/HFC blends	Refrigeration, air-conditioning

HFO

- 1) The list does not contain other HFO than HFO-1234yf for MAC applications, since (a) HFOs are still quite rare even in the industrialized countries, (b) their price is still very high, (c) their availability is limited and (d) sufficient experience working with these



gases has not yet been accumulated. These substances might play an important role in the future, but currently they can't take priority on the list of alternatives.

- 2) As for MACs, according to DuPont more than 7 million vehicles using HFO-1234yf are estimated to be on the road by the end of 2015 globally. This trend is valid for all areas, even though one major European car manufacturer announced some concerns vis-a-vis HFO-1234yf and decided to develop CO₂ technology for their car air-conditioners.

HFO/HFC blends

Such blends have been promoted by the fluorocarbon industries. There are two groups available: Blends designed to have properties similar to R22 (e.g. L-20 or DR-3) and blends designed to have properties similar to R410A (e.g. L-41-1 or DR-5). Common for these are zero ODP and GWP in the range 300-500. All are mildly flammable – A2L as per ASHRAE-34. The blends contain R32 and HFO-1234yf or HFO-1234ze as well as one or two additional components; and have temperature glide in the range 3-8K. Prices are still unknown.

Another group of similar blends with GWP around 1000 exists as well. Finally a second generation of blends is now being considered with GWP below 150; however, these are still at design stage.

The higher refrigerant price, GWP or maturity/availability will be the barriers to adopt HFO/HFC blends as alternatives to R22 in RAC appliances.

Hydrocarbons

In Federal Register / Vol. 80, No. 138 / Monday, July 20, 2015 (Protection of Stratospheric Ozone: Change of Listing Status for Certain Substitutes Under the Significant New Alternatives Policy Program; Final Rule) “EPA has listed R-290, R-600a and R-441A are acceptable subject to use conditions in new stand-alone equipment. R-290 is already in use globally, including in the United States, and R-600a is in use outside of the United States as well as in test market trials in the United States.”

This decision has an important impact for many developing countries, especially Latin America, where due to the influence of US exporters equipment charged with hydrocarbon refrigerants has not been widespread.

In the Expert Group Meeting mentioned earlier remarkable results of a project retrofitting existing air-conditioning (room a/c and chiller) were presented. The positive results of the programme indicate the possible viability of wide-range use of hydrocarbons, especially in in open-air installations. However, in undertaking this type of exercise appropriate assessments are required to identify and mitigate potential risks of the conversion process.

It is also well known that R-600a is the refrigerant of choice in the domestic refrigeration



sector of many countries including the large manufacturer and exporter China, Europe and other Asian countries. Thus, the arrival of such goods to the market of all A5 countries is imminent.

Apart from commercial refrigeration (coolers, vending machines, etc.) R-290 is coming up in the air conditioning sector as well. Portable air-conditioners and dehumidifiers charged with R-290 are already manufactured in some countries.

China and India started production of R-290 split a/c appliances. The major problem here is that in many countries due to the flammability of propane the maximum refrigerant charge is limited by the standards, hence the capacity of the appliances is below 5 kW. This issue is being reviewed and the technology is under further development, thus it might be resolved in the foreseeable future. China, as the world leader in this sector has converted a number of RAC and compressor lines and stands ready to put these appliances on the global market as soon as national standards are updated.

HFC

HFC-s are to be regarded as transitional substances. Nevertheless, they are still in wide use since no better alternatives are available at this time.

Room air conditioners are widely spread in A5 countries and the bulk of HCFC refrigerant consumption is attributable to this sector. Until the aforementioned problems associated with the use of R-290 in RACs are resolved HFC-410A will be on the market of A5 countries in large quantities. Room air conditioners charged with HFC-410A are still mass-produced in a number of countries and are being exported to A5 countries.

R-32 is the preferred RAC refrigerant in Japan. This refrigerant has a GWP of 675 and it is slightly flammable. China as the global leader prefers R-290 and the EU will gradually ban refrigerants with GWP over 150, thus it is still a question whether R-32 will have sizable presence in A5 countries.

CO₂ (R-744)

CO₂ system efficiency is good at lower ambient temperatures; however CO₂ system efficiency suffers at higher temperatures. While some companies, especially Coca Cola have earlier decided to specify CO₂ refrigerant in their purchases of new coolers and vending machines this company is reconsidering its policy in some countries due to the prevailing high ambient temperatures; currently R-290 is being considered instead.

CO₂ technology is being applied in the retail/supermarket sector as well.



PROPOSED SOLUTIONS

A. Improvement of refrigerant quality

In order to improve the quality of refrigerants on the domestic market it is crucial to manage the supply chain of refrigerants in a holistic way.

The formulation and implementation of such a framework should start with a comprehensive **fact finding survey** including:

- a) Situation and size of the sector;
- b) Current regulatory framework of the sector;
- c) Volume and types of refrigerants in the country;
- d) Identification and assessment of the needs and challenges faced by the sector, etc.

Furthermore, it is necessary to **identify all national stakeholders**, such as

- a) Government departments;
- b) Customs authorities;
- c) Refrigerant importers;
- d) Refrigerant wholesalers and distributors and their associations;
- e) Larger service enterprises;
- f) Important end-users and operators;
- g) Technicians and their associations;
- h) Academia;
- i) Training institutions;
- j) Standardization bodies;

The data collection and demand assessment should be followed by formulation, introduction and enforcement of proper **national standards** based on F Gas Regulations, ISO 817 or ASHRAE 34 standards. The new national standard should be adapted to local conditions and legislation

The next step is to **regulate the refrigerant market** through:

- a) Elaboration and introduction of the approval criteria for putting a refrigerant on the domestic market;
- b) Designing and piloting of a monitoring scheme to control and ensure that the quality of refrigerants on the market conforms with the standard;
- c) Establishing a licensing system restricting the sale and purchase of **all types** of refrigerants to those enterprises and entities who fulfill the minimum training and expertise requirements and possess a minimum set of equipment;



- d) Enforcing traceability of refrigerant consignments. Larger consumers (e.g. ≥ 50 kg/year) should keep record of the movement of refrigerants: purchased, used, sold, recovered, reclaimed and disposed (material balance). This would reduce the risk of putting on the market and use non-standard refrigerants and/or venting refrigerants.
- e) Establishment and daily operation of an Internet based refrigerant flow monitoring system. The data registered in the previous paragraph would be fed into this database run by the control institution;
- f) Setting up and empowering control institution(s) for regular and random check of refrigerants at the distributors and large consumers (≥ 100 kg/year);
- g) Strengthening customs procedures to control all types of refrigerants and restricting cross-border movement of refrigerants to standardized ones only;

As explained earlier professional **training and equipping stakeholders** is of high priority. It is proposed to organize the following activities:

- a) Training of authorities involved in the supervision and regulation of the refrigerant supply chain;
- b) Equipping and continuous training of customs officers in identification of all standard refrigerants;
- c) Training and certification of refrigerant distributors – these entities were never considered by MP projects;
- d) Training service technicians, service companies and larger scale refrigerant users on proper selection of refrigerants and on the possible positive and negative consequences of refrigerant selection (economic value of refrigerant stock, efficiency gains through selection and use of proper refrigerants, environmental and safety impacts, etc.);
- e) Preparation of case studies to demonstrate the overall cost and impact of using inadequate refrigerants;
- f) Awareness campaigns.

B. Containment and Refrigerant Leakage Prevention

The methodology to be used by the demonstration project will be based on an internationally acknowledged certification scheme. It will be formulated on the basis of the EU common certification scheme and the results of the Refrigerant Emissions and Leakage Zero project (REAL ZERO, Real Skills Europe) <http://www.realskillseurope.eu/>. The aim is to achieve reductions in refrigerant leakage. It is a structured methodology for undertaking site surveys; assessing and minimizing leakage potential, together with an e-learning training scheme, software tools and guidance notes.

In more details, **REAL Zero** is a project initiated by the Institute of Refrigeration (UK) to investigate the causes of and solutions to refrigerant leakage, against the background of the



EU F Gas Regulation. It brings together expertise across sectors and provided practical guides and training resources. The REAL Zero concepts have been adapted into European e-learning programmes REAL Skills and REAL Alternatives. REAL Alternatives applies the knowledge, tools and experience in containment to alternative refrigerants (carbon dioxide, ammonia, hydrocarbon and new low flammables HFOs and R32).

The REAL Zero (Refrigerant Emissions and Leakage Zero) brand offers:

- a) Guidance on reducing leakage as part of technicians and operators work and promoting a zero tolerance approach to leakage;
- b) Tools to communicate the importance of leakage reduction to customers and evidence of its positive impact;
- c) Templates for site surveys and reports on leakage costs;
- d) Training materials to develop technicians' and operators' knowledge and for improving containment and the safe, reliable use of a wide range of refrigerants;
- e) Optional Certification and Assessment plans to provide evidence of the trainees' commitment and knowledge.

To implement a Containment and Refrigerant Leakage Prevention Programme the following actions are recommended:

Survey and needs assessment

- a) Identification of national stakeholders (such as governments, customs authorities, private sector, technicians, academia and international and regional standard bodies etc.), refrigerants and tools used both in the manufacturing and servicing sector;
- b) Implementation of a special training program for the site surveys on refrigeration containment and leakage reduction, related data collection, calculation, use of logbooks;
- c) Evaluation of national capacities to implement ISO standards and regulations similar to F-Gas regulations;
- d) Identification of pilot activities and institutions.

Regulatory framework for certification of technicians

- a) Formulating and issuing national regulations and a scheme for certification of technicians;
- b) Compile certification tests – (a) multiple choice test on theory and (b) practical skills examination;
- c) Setting up institutions able to issue certificates of various levels;
- d) Empowerment of certification institution;
- e) Issue regulations tying performance of tasks of various complexity and risk level with the levels of certificates offered within the certification scheme;



- f) Compile a minimum requirements for certification of technicians consisting of:
- i. Mandatory equipment e.g. for technicians completing installation, servicing, repair, leak testing of refrigeration and air conditioning equipment, recovery and handling of refrigerants. It should include at least:
 1. Recovery machine
 2. Cylinder for recovery with double valves
 3. Double stage vacuum pump
 4. Kit of brazing tools
 5. Manifold, 4 ways (to be certified every year)
 6. Balance (to be certified every year)
 7. Ampere-meter clamp (to be certified every year)
 8. Leak detector (to be certified every year)
 9. Nitrogen kit for testing leaks under pressure
 - ii. Training requirements tailor made for the maximum complexity and risk level of task, which an applicant is allowed to perform;
 - iii. Minimum level of working experience etc.
- a) Issue and periodically reissue certificates authorizing the technicians to perform tasks of certain complexity.
 - b) Work out conditions and agreements for issuance of internationally valid certificates or with validity at least within the region, like it is now within the EU;
 - c) Enforce requirement of certification within the country through appropriate legislation;

Training programme

- a) Design and pilot theoretical and hands-on practical training program and e-learning module. The training curriculum should focus on best practices, energy efficiency measures, flammable alternatives, installation, service and recovery skills and environment consideration;
- b) Needs assessment for the upgrade of available training facilities, defining list of equipment and tools necessary for future trainings;
- c) Training of trainers;
- d) Training of operators, technicians and distributors handling refrigerants.



Establishment of all-inclusive associations for service companies and technicians

This action is not part of the Zero Leak standard package, but it is an important tool to not only to represent the interest of the trade but also to exercise voluntary control and regulate the activities of technicians belonging to the association.

Improvement of refrigerant recovery, recycling and reclamation skills

To improve refrigerant containment, there is a need to upgrade recovery and purification skills and practices to reduce risk of venting of retired refrigerants. With this aim in mind it is proposed to complement the standard Zero Leak project with activities related to this last stage of the lifecycle of refrigerants.

The original idea to recover, recycle, reclaim and stock CFC refrigerants for future use at times when virgin CFCs will not be available anymore did not fully materialize. The amount of refrigerant collected has been very small and even if part of the working fluids was reused on spot (mainly in large commercial and industrial systems), most of the refrigerants contained in the retired appliances and refrigeration/air-conditioning equipment cannot be accounted for.

A portion of the collected refrigerants was mixed or for some other reasons it was not possible to reuse them.

In many cases refrigerants were collected and cleaned. However, due to the high cost of collection, treatment, transportation of the second hand refrigerants they could not compete with the relatively cheap virgin refrigerants. In addition, with lack of certification of the reclaimed refrigerant, there is no trust in the product and there is no financial incentive either to buy it.

It is to be noted, that transportation and export of refrigerants require fulfillment of strict conditions and procedures, since they fall under the category of hazardous wastes. Moreover, the destruction centers instead of paying for the refrigerants delivered to them, charge large fees for refrigerant destruction.

As a result, both the cleaned and the mixed refrigerants have been stranded at the recovery, recycling and reclaiming or collection centers that are unable to sell the gases at prices that allow recovery of the high costs associated with the collection, transportation and treatment or disposal.

All these circumstances constitute a major hindrance and may cause suspension of recovery of refrigerant waste. Thus, large amounts of refrigerants have been and continue to be released during operation and major repairs or at the end of the lifetime of refrigeration and air-conditioning equipment.



The Multilateral Fund tried to assist A5 countries by approving refrigerant destruction projects in a few countries. Equipping all countries with at least small destruction facilities would be a very costly exercise and would not resolve the core problem. Instead of building large number of destruction facilities, it is recommended to prepare an overarching strategy to handle all refrigerant wastes. This strategy is based on the following considerations:

- a) Refrigerant wastes embody material resources, energy and work. These finite resources and expenses are not to be simply wasted; even if the retired refrigerant is a waste for the refrigeration equipment owner it could represent a useful resource for some other entities.
- b) Destruction in itself is a costly process associated with negative environmental impact. Thus destruction should come into play only as a last resort, when no other option is possible.
- c) Refrigerant waste management is not an isolated process; it is part of the overall refrigerant cycle and should be looked at it in a holistic way.
- d) Economic drivers should govern selection and application of the most appropriate waste treatment solution; and the entire process should be self-financing and sustainable. However this would raise questions like governmental subsidies of the process or introducing a levy on all types of refrigerants. Currently, in view of political difficulties and financial constraints such or similar enabling actions are not welcome by the ozone officers in the recipient countries selected for the project. Nevertheless at least a discussion on this matter and keeping it on the agenda could prove to be useful.

C. Introduction of low GWP alternatives

The following measures are proposed to reduce the barriers of wide scale introduction alternative refrigerants in A5 countries:

- a) Organize training and awareness programmes for technicians on operating and installation requirement of new generation of refrigeration and a/c equipment. Such training courses are also part of the Real Skills Europe programme and they are described in the previous chapter;
- b) Hydrocarbons (HCs), such as R290 (propane) are highly flammable. Among others, specialized training for technicians on flammability needs to be done to ensure that only well-trained technicians service hydrocarbon-based equipment. Detailed actions for the wider adoption of HCs are described in the proposal.
- c) CO₂ is working at pressures that are significantly higher than is the refrigeration norm, so here also special training on servicing such equipment as well as proper tools should be made available to a growing number of technicians;
- d) Ammonia is less common and it is used in larger installation. Such equipment is usually purpose made and the OEM, who also provides initial training of the staff,



- guides the installation. Thus training activities on handling and using this refrigerant and technology should be oriented to a target group of technicians only;
- e) Operators and maintenance staff as well installers should have strong training on the safety requirements for installation and servicing of equipment charged flammable and/or toxic refrigerants;
 - f) Refrigeration service technicians should be equipped with suitable tools and acquire appropriate practical skills to perform their tasks with the new and in many cases somewhat more hazardous refrigerants;
 - g) Training of MAC technicians should concentrate on HFO and CO₂ technology.
 - h) Many issues related to training on equipment installation, operation and maintenance as well as handling and distribution of low-GWP refrigerants are similar to those described in the previous chapters, so no repetition is required.

The findings of the discussions related to the three issues posed by UNIDO (refrigerant quality, refrigerant containment and introduction of alternatives) suggest that the issues are interlinked and they should be handled as part and parcel of common strategy/concept.

IMPLEMENTATION STRATEGY

During the preparatory phase of the demonstration project, numerous challenges have been identified in the refrigeration servicing sector, which apart from the global aspects, also show regional characteristics. The project elements have been designed accordingly covering different regions / countries (e.g. refrigeration containment and quality standards in Africa, safe use of flammable refrigerants in the Caribbean, leakage reduction in Egypt and refrigerant waste management in Mexico). However, in order to prove that the suggested activities can make a real difference in the refrigeration servicing sector, they should be implemented at the same time and place. To demonstrate the ultimate impact of the initiative, Macedonia has been selected as a **pilot country**.

The present demonstration project will be implemented through five subprojects. They do not contain all activities suggested above, but designed to focus on the most urgent issues addressing the specific needs of the submitting countries and regions.

The subprojects contain the country/region specific activities, beneficiaries and target groups, expected outcomes and their sustainability, as well as the implementation schedule and budgets.

The sub-projects also describe the relevance and demonstration value of the proposal as well as the strategy of dissemination of results and lessons learnt. Through these actions interested A5 countries can replicate the pilot projects.

The attached sub-projects are:

- **ANNEX I: Macedonia – Holistic Approach for the Improvement of the Refrigeration Servicing Sector**
- **ANNEX II: Egypt – Refrigerant Containment and Refrigerant Leakage**



Prevention – Based on the REAL Zero Initiative

- **ANNEX III: Mexico – Innovative Scheme for Minimization of Refrigerant Wastes and Safe Management of Recovered Refrigerants**
- **ANNEX IV: Caribbean region (the Bahamas, Grenada, St. Lucia, St. Vincent and the Grenadines, Suriname) – Safe handling of low-GWP flammable refrigerants**
- **ANNEX V: East African region (Eritrea, Kenya, Tanzania, Uganda, Zambia) – Standards and Market Availability of Quality Refrigerants**

PROJECT BUDGET

Each sub-project contains a sub-project specific budget. The overall budget is shown below:

Subproject	Budget [USD]
Macedonia	300,000
Egypt	150,000
Mexico	225,100
Caribbean region	220,000
East African region	210,000
GRAND TOTAL	1,105,100



ANNEX I

REPUBLIC OF MACEDONIA SUB-COMPONENT

Country	The Republic of Macedonia
Title	Holistic approach for the improvement of the refrigeration servicing sector
Project Duration	24 months
Demonstration Project Budget	US\$ 300,000
Implementing Agency	UNIDO
National Counterpart	National Ozone Unit

1. BACKGROUND

1.1 Country Information and HCFC Phase-out Management Plan

The Republic of Macedonia is one of the fastest developing countries in the Europe & Central Asia (ECA) region with a population of over 2 million. Given the increasing economic performance of the country, refrigeration and air-conditioning equipment are not luxury goods anymore, but basic part of more and more people's life. Nevertheless, national stakeholders work in close and fruitful cooperation to ensure that the country is in compliance with the Montreal Protocol. Thanks to well-targeted activities, the Republic of Macedonia is at a very advanced stage of the HPMP implementation, even when compared to other countries of the region.

The HCFC phase-out management plan (HPMP) for the Republic of Macedonia was approved in 2010 at the 60th Meeting of the Executive Committee of the Multilateral Fund for UNIDO's implementation. The first Stage of the HCFC Management Plan covered the freeze of the HCFCs consumption in 2013 (baseline level - annual consumption in 2009-2010), the 10% reduction by 2015 and subsequent 5% reduction each year till 2020, reaching 35% reduction in total.

The HPMP covers the following main aspects:

- Training of trainers and technicians
- Customs Administration capacity building
- Equipment recording and labelling
- Licensing system
- Completion of the conversions in manufacturing industries.



1.2 Historical consumption of ODS alternatives

Starting from the year 2000, the Ministry of Environment and Physical Planning is the entity, which controls the import of HFCs and HFC-blends. The data given in the Table 1 below provides HFCs import / consumption figures for the period 2000 – 2014. It should be noted that data for the period from 2000 - 2010 are based on issued import permits, and data from 2011 - 2014 is actual HFCs import in the country.

Table 1: HFCs consumption (2000 -2014)

Substance/ Blend	2000	2001	2002	2003	2004	2005	2006	2007	2008	2009	2010	2011	2012	2013	2014
HFC-134a	13,87	64,97	3,45	28,56	100,03	54,24	82,66	35,96	51,61	44,69	25,85	24,07	29,41	35,63	56,82
R-404A	3,05	12,06	8,95	15,16	29,55	36,28	60,61	31,13	73,66	36,33	41,13	12,91	11,42	27,68	27,59
R-407C		1,00	2,71	1,36	1,69	3,33	5,81	12,35	10,19	11,69	14,63	2,85	2,68	7,51	3,31
R-410A			0,33				0,41	10,69	9,74	11,00	13,39	1,82	7,79	8,51	6,77
R-507		0,30		0,16	0,31	1,14	2,55	0,85	15,30	7,78	16,58	0,57	1,12	0,77	0,89
R-227ea (FM 200)		1,38		1,00	0,52	1,52	2,00	2,07	2,50	2,18	7,00		7,07		0,02
R-417														0,05	
Total (MT)	16,92	79,71	15,44	46,24	132,09	96,51	154,03	93,05	163,00	113,66	118,58	42,22	59,48	80,14	95,39

In the period 2011-2014, HFC 134a dominates with about 53% followed by 29% of R-404A and 9% of 410A.

According to the existing national legislation, there are no limits or any other manner for the reduction of HFCs import and consumption. The importers or the end-users are not obliged to report the manner of HFCs or other HCFC alternatives' application.

Regarding the HCFC alternatives contained in the cooling equipment it is important to mention that in the year 2011 the import of HCFC air-conditioners was limited to 20,000 units, and in the year 2012 the overall import of HCFC air-conditioners was banned. In the year 2011 the import of HFC air-conditioners was more than double compared to the HCFC one. The Table below shows the increasing trend of non-ODS equipment import. It could be noticed that a significant amount of HFCs has been imported in the equipment between 2011 and 2014. A simple calculation for four years gives about 86 MT (an average air-conditioner contains approximately 1 kg refrigerant fluid).

Year	Imported equipment quantity			
	Air-conditioners		Refrigerators	
	Non-ODS refrigerant	ODS refrigerant	Non-ODS refrigerant	ODS refrigerant
2011	13,642	5,923	49,665	/
2012	27,743	/	49,735	/
2013	26,577	/	37,200	/
2014	18,182	/	34,978	/

1.3 Policy Background

The Ministry of Environment and Physical Planning adopted a range of legal acts regulating refrigerants management. The legal framework in the refrigeration area could be grouped into the following categories:

- Legislation on refrigerants management
- Legislation on equipment containing ODS/non-ODS refrigerants
- Leakage prevention, recovery and recycling regulations
- Licensing and certification system

1.4 Recovery & Recycling

In the Republic of Macedonia there is a very well-functioning, self-sustaining recovery and recycling scheme. Thanks to the arrangement of distribution of the recovery and recycling equipment to 55 service shops and the delivery of relevant training activities under the HPMP, the country achieved **outstanding results in the recent years in the field of R&R** as per Table 2.

Table 2: Recovery and recycling 2001-2014 (in kg.)

May 2001 - Dec 2002	2003	2004	2005	2006	2007	2008	2009	2010	2011	2012	2013	2014
2,820.9	2,466.1	7,101.6	7,191.5	5,452.8	8,089	10,407.8	6,765	8,406.2	10,921	11,813	14,042	21,872

2. PROJECT OBJECTIVES

The objective of the project is the holistic improvement of the refrigeration-servicing sector in a way that the identified challenges are addressed simultaneously. This will result in the

- more efficient operation of equipment through improved refrigerant quality and leakage reduction,
- establishment of a refrigerant reclamation scheme and
- promotion of alternatives with low global warming potential.

3. PROJECT STRATEGY

During the preparatory phase of the demonstration project, numerous challenges have been identified in the refrigeration servicing sector, which apart from the global aspects, also show regional characteristics. The project elements have been designed accordingly covering different regions / countries (e.g. refrigeration containment and quality standards in Africa, safe use of flammable refrigerants in the Caribbean, leakage reduction in Egypt and refrigerant waste management in Mexico). However, in order to prove that the suggested activities can make a real difference in the refrigeration servicing sector, they should be



implemented at the same time and place. To demonstrate the ultimate impact of the initiative, Macedonia has been selected as the **lead pilot country**.

The demonstration project will not only promote the improved capacity, safer and more efficient operation of equipment currently in use in the refrigeration and air-conditioning sector, but will also propose a refrigerant reclamation scheme for the efficient reuse of HCFC and HFC refrigerants and will promote the use of low GWP alternatives.

Thanks to this **proactive, multi-level project strategy** the refrigeration servicing sector could go through significant improvements, which will also give a boost to the ongoing Stage I HCFC Phase-out Management Plan, while the lessons learnt will largely contribute to the strategy of Stage II HPMP and could even be integrated in the HPMPs of other countries.

4. PROJECT BENEFICIARIES

The experience gained during the RMP, TPMP and HPMP implementation shows that the main players in the overall process for refrigerants management could be identified as follows:

- GOVERNMENT DEPARTMENTS:
 - Ministry of Environment and Physical Planning
 - Ministry of Economy
 - Standardization Institute of the Republic of Macedonia
 - State Statistics Office
 - Customs Administration
 - Ministry of Education
 - Ministry of Health

- National RAC Association

- Private sector (equipment owners, service enterprises)

- Refrigerant importers and in-country sellers

- End-users

5. PROJECT IMPLEMENTATION

The project builds on activities in the field of policy support, technical assistance and awareness raising and offers services in three main areas:

5.1 IMPROVED REFRIGERANT QUALITY AND LEAKAGE REDUCTION

5.2 ESTABLISHMENT OF A REFRIGERANT RECLAMATION SCHEME

5.3 PROMOTION OF ALTERNATIVES WITH LOW GLOBAL WARMING POTENTIAL



5.1 IMPROVED REFRIGERANT QUALITY AND LEAKAGE REDUCTION

The project aims to strengthen and expand the currently existing certification and monitoring scheme to ensure refrigerant quality and reduced leakage. Some preconditions for adequate refrigerant certification and monitoring scheme are already in place such as certain legislation and database; however, certain improvements are still needed.

Since there is no refrigerant production in the country, refrigerants are imported by seven to eight companies. The **quality is guaranteed by the importing company and there is no further quality control mechanism in place**. Obtaining the certificate by the end-users is the most commonly used manner to confirm the refrigerants' quality. Regulation (EC) No 1272/2008 on classification, labelling and packaging of substances and mixtures gives provisions on labelling of substances (including ODS and non-ODS refrigerants) and the labelling of mixtures containing such substances. According to the Law on Chemicals (Official Gazette of the Republic of Macedonia no.145/10, 53/11, 164/13, 116/15, 149/15) the Ministry of Health is responsible for the classification and labeling of chemicals and mixtures, as well as registration of legal entities trading with chemicals. However, **there is no specific legislation that requests registration and authorization of refrigerant importers, distributors and large consumers**.

In the context of the HPMP **significant work has been carried out to avoid refrigerant leakage** and raise awareness. However, with the innovative approach of the **REAL ZERO initiative**¹, the demonstration project aims at taking leakage prevention to the next level.

Since similar activities are planned to be implemented hand-in-hand with UNEP in the context of the global demonstration project under the East Africa sub-component, UNIDO intends to rely on this experience and invite UNEP to contribute with its valuable know-how.

5.1.1 Policy assistance

- Recommend and draft legislation obliging importers, distributors and large consumers for the registration and authorization of quality refrigerants and equipment as per 5.1.3 and 5.1.4.

5.1.2 Mobile Refrigerant Testing Service

- Design and establishment of the Mobile Refrigerant Testing Service.

The service will be composed of **environmental inspectors equipped with mobile testing devices** and will be **focused on refrigerant importers and in-country sellers**. The environmental inspectors who attended the training and are certified members of the Mobile

¹ <http://www.realskillseurope.eu/>



Refrigerant Testing Service will conduct the testing at the importers and the in-country sellers all over the country.

- Delivery of tools

Supply of monitoring aids and tools, e.g. advanced refrigerant identifiers.

- Training activities

Besides the use of the monitoring tools, the training activities will focus on the importance of refrigerant quality and testing and also the administration of the refrigerant quality labeling system as per 5.1.3. The training will target the staff of NOU, refrigerant importers, in-country sellers and environmental inspectors.

5.1.3 Strengthening recording and labeling scheme

The NOU has already worked on the establishment of a proper database for this purpose, including legislation, training of the involved stakeholders and target substances as well as the database itself on the collected records. The activity began in 2015 and as of today, 216 pieces of equipment have been recorded in the special logbooks and have been properly labeled. Activities under this component are designed with a view to provide sustainability to the overall recording process and overcome the gaps recognized in the first recording round. Furthermore, an improved labeling scheme will also contribute to the successful operation of the Mobile Refrigerant Testing Service: **labels will be developed to indicate quality and will be a record of inspections**. The labels for tested refrigerants should be designed with some clear pictograms to ensure clear communication with all stakeholders.

In addition, the sites and equipment assessed in the context of the leakage prevention plan as per 5.1.4 and the refrigerants reclaimed as per 5.2 will also be covered by the recording and labeling scheme.

5.1.4 Leakage prevention plan

The REAL ZERO program is based on the EU common certification scheme and is the result of the Refrigerant Emissions and Leakage Zero project. It includes the following aspects:

- Guidance on reducing leakage as part of technicians and operators work and promoting a zero tolerance approach to leakage;
- Tools to communicate the importance of leakage reduction to customers and evidence of its positive impact;
- Templates for site surveys and reports on leakage costs;
- Training materials to develop knowledge and skills of technicians and operators and for improving containment and safe, reliable use of a wide range of refrigerants;
- Optional Certification and Assessment plans to provide evidence of the trainees' commitment and knowledge.



The leakage prevention plan will complement and improve the existing framework through the following interventions:

- Design of a training/ e-learning module with guidance on data collection and calculation templates;
- Train technicians and environmental inspectors on how to conduct site surveys;
- Certify the assessed equipment/sites according to the labeling scheme as per 5.1.3;
- Collect and evaluate results of the site surveys.

5.2 ESTABLISHMENT OF A REFRIGERANT RECLAMATION SCHEME

In order to limit the use of ozone-depleting substances, the reuse of refrigerants by the technicians is highly encouraged after appropriate recovery, recycling or reclamation. As mentioned earlier, the recovery and recycling scheme is very developed in the country resulting in an outstanding quantity of recycled refrigerant. **However, the Republic of Macedonia has never received support from the MLF for reclamation, meaning that the most sophisticated option for the reuse of refrigerants is not available in the country.**

Reclamation is the re-processing and upgrading of a recovered substance **through filtering, drying and distillation in order to restore the substance to the same properties as virgin refrigerant** (as per standard AHRI 700). It involves almost always processing "off-site" at a **central facility**.

Since the reclamation of certain HFCs, such as HFC134a, HFC404 and HFC410A is possible, besides HCFCs the **reclamation scheme will also be extended to HFCs**. This will significantly contribute to the sustainability of the project given the increasing trends of HFC use in the country.

The reclamation scheme will be implemented through the following activities:

- Establishment of a business model

In order to ensure **sustainable operation of the reclamation scheme** a business model will be worked out in cooperation with the NOU, international and national experts. The model will take into consideration experience from other countries with a successful reclamation mechanism.

- Establishment of three reclamation centers

Three **service shops already carrying out R&R activities will be selected through a tendering process** and by taking into consideration aspects such as geographical location. Applicants will operate the centers based on the business model.

- **Delivery of equipment and training** of the reclamation centers' staff

Necessary equipment will be provided to each center, including advanced refrigerant identifiers, one set of reclaiming machine and kit for quality check of the reclaimed refrigerants.



- Monitoring

The NOU and the national expert will closely monitor the operation of the reclamation centers. The centers will take detailed records on their activities and submit regular reports to UNIDO and the NOU.

5.3 PROMOTION OF ALTERNATIVES WITH LOW GLOBAL WARMING POTENTIAL

Studies proved that the lack of appropriate trainings and certification of technicians along with certain misconceptions are among the biggest obstacles to the introduction of natural refrigerants. This component responds to this challenge through technical assistance and awareness raising activities, ensuring that both sides of the problem are addressed.

It will result in the **strengthened capacities of service technicians** enabling them to provide proper services and accurate information to end-users. On the other hand, by **raising public awareness**, the demonstration project intends to actively contribute to the extended use of low GWP refrigerants in the Republic of Macedonia and in the South-East European region.

Due to the high number of certified technicians and the density of service workshops in the country² training activities became the crucial point of the HPMP; the demonstration project aims to complement these efforts and provide additional impetus to vocational education and training. The goal of this component will be to educate “**super technicians**”, who are real masters of their work.

5.3.1 Technical assistance

- Identification of **two demonstration training centers**, needs assessment and delivery of equipment

Based on preliminary evaluations and consultation with the NOU and the national expert, two training centers will be identified considering their equipment, geographical coverage and infrastructure. Following the needs assessment, these two training centers will be **equipped with demonstration units running on natural refrigerants** and additional tools / toolkits.

Further activities will be performed as follows:

- Preparation of training curriculum;
- Identification of participating technicians;
- Delivery of trainings and certification of participants.

² In the comprehensive national database, initiated in 2015, the NOU has a record of 151 service shops with a wide geographical coverage. Moreover, to date, there are a total of 379 certified technicians who have successfully completed their training.



5.3.2 Awareness raising

In order to complement similar activities under the HPMP, awareness raising activities will be implemented in a South-East European, regional context. This will not only contribute to the sustainability of the whole concept, but will also widen the scope of activities.

- Regional expert group meeting

In order to share experience, data and information gained throughout the project implementation, the NOU will organize a regional workshop. This will be an excellent opportunity for the countries in the region to learn more about the holistic approach of the project.

6. ACTIVITIES TIMELINE

ACTIVITY	TIMEFRAME							
	1 Year				2 Year			
	I	II	III	IV	I	II	III	IV
Improved refrigerant quality and leakage reduction								
Policy assistance								
Design and establishment of the Mobile Refrigerant Testing Service								
Design and establishment of the leakage prevention plan								
Delivery of tools								
Training activities								
Strengthening recording and labeling scheme								
Monitor, collect and evaluate results								
Establishment of a refrigerant reclamation scheme								
Establishment of a business model								
Establishment of three reclamation centers								
Delivery of equipment and training of the reclamation centers' staff								
Monitoring								
Promotion of alternatives with low global warming potential								
Identification of two demonstration training centers, needs assessment								
Delivery of equipment								
Preparation of training curriculum								
Identification of the participating technicians								
Delivery of trainings and certification of participants								
Regional expert group meeting								



7. PROJECT SUSTAINABILITY AND DEMONSTRATION VALUE

The project proposal will provide an additional boost for the controlled use and phase-out of HCFCs. As mentioned earlier, it will complement Stage I HPMP and will serve as basis for Stage II HPMP. Moreover, the project activities will pave the way and **prepare the ground for the expansion of low global warming potential refrigerants.**

The improvement of refrigerant quality standards and certification scheme, the identification of trusted dealers/re-sellers, the training of environmental inspectors and “super technicians”, the leakage prevention plan and the establishment of a business model-based refrigerant reclamation scheme are assets that will **largely contribute to the success of any future interventions.**

This proposal could significantly contribute to the efforts of Macedonia in the context of the **accession process to the European Union**: The Republic of Macedonia should not only comply with the MP phase-out deadlines, but also needs to implement the EU F-gas regulations. Through the facilitation of the use of low GWP alternatives, Macedonia could get closer to this target and more importantly limit the use of high GWP refrigerants. Furthermore the holistic approach will be demonstrated to **other A5 countries of the region** and could be **easily replicated**, particularly in countries such as Serbia, Montenegro and Albania, which are also in the EU accession phase. The regional technology exhibition and the expert group meeting will enable participants from South-East Europe to understand the structure and the results of the project and will provide recommendations for potential replications.



8. PROJECT BUDGET

Item	Activities	Description/Remark	Cost breakdown [US\$]	Total costs [US\$]
Advisory services by National experts	<p>9. Provide advice on policy</p> <p>10. Participate in the design and establishment of the refrigerants labeling system</p> <p>11. Provide needs assessments for the reclamation centers and the demonstration training centers</p> <p>12. Participate in the design and establishment of the Mobile Refrigerant Testing Service and the leakage prevention plan</p> <p>13. Monitor the operation of the Testing Service and the leakage prevention plan</p> <p>14. Provide advice on the establishment of the refrigerant reclamation scheme and monitors its operation</p> <p>15. Organize the technicians training, draft training material</p> <p>16. Participate in the awareness raising activities, including regional meetings</p> <p>17. Assess and evaluate results</p>		Including travel	20,000
Advisory services by International Expert	<p>Provide advice on:</p> <p>18. The design of the Mobile Refrigerant Testing Service and participate in the monitoring</p> <p>19. The design of the leakage prevention plan and participate in the monitoring</p> <p>20. The design of the refrigerant reclamation scheme with special attention to its business model and participate in the monitoring</p> <p>21. The evaluation of lessons learnt</p>		Including travel	35,000
Equipment	Demonstration units	1 set of demonstration unit running on natural refrigerant per training center and additional tools when needed	2 demonstration training centers identified 2 x 30,000	60,000



Demonstration Project on Refrigerant Quality, Containment and Introduction of Low GWP Alternatives

	Monitoring tools	To be used by the Mobile Refrigerant Testing Service and the leakage prevention plan		25,000
	Reclamation machines	Reclamation machines, kit for quality check and advanced refrigerant identifiers to be used by the new reclamation centers	3 reclamation centers identified 3 x 15,000 3 x 1,000 3 x 6,500	67,500
Training	Training of environmental inspectors	50 participants		10,000
	Training of "super technicians"	20 participants		10,000
	Training of reclamation center staff	20 participants		10,000
Refrigerant quality and leakage	Design, establishment and monitoring of the Mobile Refrigerant Testing Service	Service provided by environmental inspectors equipped with mobile testing devices		15,000
	Design and establishment of the labeling system	Labeling to be used an indication of quality and a record of inspections		17,000
	Leakage prevention plan	Based on REAL ZERO initiative		10,500
Awareness Raising	Regional meetings and information sharing			20,000
TOTAL				300,000



ANNEX II

EGYPT SUB-COMPONENT

Country	Egypt
Title	Refrigerant Containment and Refrigerant Leakage Prevention– based on REAL Zero Initiative
Project Duration	18 months
Demonstration Project Budget	US\$ 150,000
Implementing Agency	UNIDO as Lead Agency and UNEP as co-operating agency
National Counterparts	National Ozone Unit- Egyptian Environmental Affairs Agency

1. BACKGROUND

In 2007, the Parties to the Montreal Protocol agreed to accelerate the phase-out of hydrochlorofluorocarbons (HCFCs) as the remaining main ozone depleting substances also because of the substantive climate benefits of the phase-out. In the following years, Parties operating under the Montreal Protocol's Article 5 (developing countries) have formulated their HCFC Phase-out Management Plans (HPMPs) for implementation under financial assistance from the Multilateral Fund for the Implementation of the Montreal Protocol (MLF).

Leakage of refrigerants from industrial refrigeration and air conditioning (RAC) systems is contributing substantially to direct emissions of refrigerants into the atmosphere and thus contributing to ozone layer depletion and global warming. Under the regulations adopted in A-2 countries (such as the EU F-gas Regulations) operators of RAC systems are required to perform regular leak testing and must not add more refrigerant without first identifying and repairing the source of the leak. There are also strict requirements on recovery of refrigerant from systems, recording of refrigerant use and labeling of equipment. Such regulations are expected to be adopted by A-5 countries hence it is needed to ensure that operators of RAC systems in A-5 countries can comply with the regulations and to reduce potential and actual sources of refrigerant leakage.

The combined environmental and financial impact of refrigerant leakage is significant.

In many A-5 countries preventive maintenance and containment control of refrigeration and air-conditioning equipment is usually rare and/or of low technical level and refrigerants in many cases are vented. The underlying reasons are insufficient knowledge of technicians, operators, equipment owners, lack of service tools, improper servicing techniques and leak



detecting equipment and techniques as well as low awareness of the cost, technical and environmental impact of poor containment.

Consequences of the above-described situation include safety hazards inefficient operation of refrigeration and cooling equipment (reduced cooling capacity, increased energy consumption) reduced life time of RAC equipment as well as increased environmental impact (ODP, GWP, toxicity).

2. PROJECT OBJECTIVES

The proposed demonstration project will promote a proactive approach to refrigerant containment and leakage reduction through education and awareness, as well as application of best practices in service/maintenance of RAC equipment. These are effective short-term measures and have major impact on the level of reduction of virgin refrigerant consumption. The demonstration project will result in increased awareness of the effectiveness and cost-efficiency of refrigerant containment and leakage reduction approaches in A-5 countries. Its replication will build capacity and local expertise in other A-5 countries to conduct site surveys for refrigerant containment and leakage reduction. The project methodology would be easily replicated in other A-5 countries and eventually incorporated into stage II HPMPs in several A-5 countries.

3. PROJECT STRATEGY

The methodology to be used by this project component will be based on an internationally acknowledged certification scheme. It will be formulated on the basis of the EU common certification scheme and the results of the Refrigerant Emissions and Leakage Zero project (REAL ZERO, Real Skills Europe) <http://www.realskillseurope.eu/>. It is a structured methodology for undertaking site surveys and assessing and minimizing leakage potential, together with an e-learning training scheme, software tools and guidance notes.

The REAL (Refrigerant Emissions and Leakage Zero) brand offers:

- i) Guidance on reducing leakage as part of technicians and operators work and promoting a zero tolerance approach to leakage;
- ii) Tools to communicate the importance of leakage reduction to customers and evidence of its positive impact;
- iii) Templates for site surveys and reports on leakage costs;
- iv) Training materials to develop technicians' and operators' knowledge and for improving containment and the safe, reliable use of a wide range of refrigerants;
- v) Optional Certification and Assessment plans to provide evidence of the trainees' commitment and knowledge.

The project will also ensure local specificity and relevant institutional framework where it will be incorporated as part of the national technical framework for the refrigeration and air-conditioning. Egypt has just completed the process of renewing its National Code for



Refrigeration and Air-Conditioning, which is developed by a national committee of experts and endorsed by the government of Egypt represented by the Ministry of Housing. The National Code, which is extracted from the regional Arab RAC Code, includes a detailed chapter on the environmental requirements for managing and handling refrigerants including procedures of containment, preventing emissions, good service, R&R, labeling and record keeping. This national code will form a strong foundation for the demo project and both will complement each other i.e. the National Code will be the regulatory framework that supports the success of the demo project while the demo project will be one of the strong enforcing tools for the National Code. The Arab Code was developed in consultation with UNEP and considerations relevant to the Montreal Protocol are well reflected in it.

The demonstration project will be implemented with full support and cooperation with the National Ozone Unit of Egypt in cooperation with relevant authorities involved in managing and monitoring the refrigeration and air-conditioning installations. The demonstration project will be complementary to recovery and recycling activities implemented under the HPMP.

4. PROJECT IMPLEMENTATION

Implementation of the project component requires the following activities:

A. Survey and identification of target sectors

- a) Clustering the targeted sectors by categorizing the servicing sector in terms of size of installed units, refrigerants charge, type of applications and average leakage rates;
- b) Evaluation of national capacities and needs to implement and enforce refrigerant containment requirements of the national refrigeration and air-conditioning code;
- c) Design and implementation of special training program for pilot sites in each surveyed category including training and certification on refrigeration containment and leakage reduction, related data collection, calculation, use of logbooks;
- d) Discuss, develop and conclude a comprehensive certification programs for sites including large and medium scale RAC applications to comply with the national code and refrigerant containment requirements.

Detailed Activities:

- a) Clustering and categorizing the target sectors

In order to build up a training and certification program on refrigerant containment and refrigerant leakage prevention, there is a need to survey and identify the key sectors that will be targeted under the project. This component will include the following:

- i. Forming a national survey team in cooperation with local specialized institutes at Cairo University, Housing and Buildings Research Center and ASHRAE Chapter in Egypt.



- ii. Conduct local survey for collecting information on large and medium (suggested 50 TR and above) scale applications in different areas of the RAC sectors i.e. commercial A/C, industrial refrigeration and commercial refrigeration.
- iii. Analyze the survey results to categorize the sector in terms of size of installed units, refrigerants charge, type of applications, average leakage rates and existing servicing practices.

b) Evaluation of national capacities

A local advisory team will evaluate the training and certification requirements to build a training and certification program on refrigerant containment and refrigerant leakage prevention. This evaluation process will include:

- i. Assessment of training programs and facilities that can accommodate the targeted training
- ii. Stakeholders consultation meetings which includes key buildings' owners, consultancy firms and major servicing companies

c) Design and implementation of special training program

Based on the results of the survey and the evaluation of national capacities, NOU and the respective authorities, with support from the local advisory team, will design special training programs for RAC installations Operators (building owners, service companies, others) to enforce the requirements of national RAC Code with regard to refrigerant containment and refrigerant leakage prevention. The training program will include:

- i. Guide to good leak testing including illustrated guide common leaks
- ii. Guide for Service and maintenance contractor's responsibility
- iii. Guide for Equipment owner's responsibility
- iv. Guide for monitoring and recording leak

d) Discuss, develop and conclude a comprehensive certification programs

The certification program will be designed to award certificate to sites with large and medium scale RAC applications which comply with the national code and refrigerant containment requirements. The program will be accompanied by annual or half-yearly inspection and verification program. The details of the certification program will be discussed and concluded based on the results of the assessment and evaluation stages. The program will include the following activities:

- i. Local Advisory Team to suggest the certification scheme including the awarding categories, checklists, scoring sheets and the inspection sheets
- ii. Local authorities to build the monitoring and inspection program for refrigerant containment and refrigerant leakage prevention including the responsibilities of different governmental parties in enforcing the system
- iii. The certification program, under the demo project, support the training and certification of pilot sites in each category identified in the survey and evaluation stages.



B. Evaluation and dissemination of results

The evaluation and dissemination of results will be done through the following:

1. Final stakeholders’ survey and meeting to compile feedback from beneficiaries and participated stakeholders in the project.
2. National campaign to promote the Training and Certification Program
3. Linking the outputs of the project with Stage-II of the HPMP of Egypt which is currently under preparation
4. Develop special report and materials for disseminating the results and lessons learned to other A5 countries.

5. ACTIVITIES TIMELINE

Activities	1-3 Months	4-6 Months	7-9 Months	10-12 Months	12-15 Months	16-18 Months
Forming local Survey Team	X					
Forming Local Advisory Team	X					
Survey and identification of target sector	X	X				
Evaluation of national capacities	X	X				
Design and implementation special training program		X	X	X		
Discuss, develop and conclude a comprehensive certification programs			X	X	X	
Evaluation and dissemination of results					X	X

6. PROJECT SUSTAINABILITY AND DEMONSTRATION VALUE

In the pilot phase, this demonstration project will be implemented in Egypt only. After evaluation of the results, further phases will target owners of RAC installations in the neighboring countries especially in countries using the same reference Arab Code. The project results will be also shared globally with other A5 countries using UNEP's networking and clearinghouse functions and activities.

At the national level, the project will be resulting in a sustainable training and certification program, which will be managed by local authorities and institutes and will be supported as well with relevant training and technicians’ certification programs that will be part of Stage-II of the HPMP of Egypt.



7. PROJECT BUDGET

Activity	Description and budget breakdown	Cost to UNIDO US\$	Cost to UNEP US\$	Total Cost US\$
Survey and identification of target sector	- Survey team managed by local institute to cover collecting data from three sectors (Commercial A/C, Commercial Ref and Industrial Ref) for 4 month. Average team cost is 2,000 per month (3-4 surveyors as part time). Total of US\$ 24,000 - Transportation, communication and logistical cost US\$ 6,000	30,000		30,000
Evaluation of national capacities	- Stakeholders/ consultation meetings @ US\$ 2,000 - Field survey on training capacities in different governorates @ US\$ 6,000 - Documentation, transportation, communication and logistical cost @ US\$ 2,000		10,000	10,000
Design and implementation of special training program	- National Advisory Team (experts level) for designing training materials (3-4 Experts) @ average of US\$ 5,000/month for 3 months totaling US\$ 15,000 - On-Site and at Institute(s) training at the selected pilot sites for the three categories (at least 8-10 sites in each category) @ US\$ 1,500 per site including trainers and materials cost and totaling around US\$ 40,000 - Management and administration of the training program @ US\$ 5,000	60,000		60,000
Design comprehensive certification programs	- National Advisory Team (experts level) for designing certification scheme and checklists (3-4 Experts) @ average of US\$ 5,000/month for 2 months totaling US\$ 10,000 - National Consultation meetings (authorities and key stakeholders) for reviewing and finalizing the certification program @ US\$ 2,000 - Pilot Certification of the selected sites including the inspection visits, evaluation and issuing certificates @ average of US\$ 8,000		20,000	20,000
Evaluation and dissemination of results	- Final stakeholders' survey and meetings for evaluating the training and certification program @ US\$ 10,000 (UNIDO) - National campaign to promote the Training and Certification Program including local travel of experts to present the program at different regional venues @ US\$ 10,000 (UNIDO) - Development of comprehensive reports and awareness materials for promoting the program in other neighboring and A5 countries @ US\$ 10,000 (UNEP)	20,000	10,000	30,000
Total cost to UNIDO		110,000		150,000
Total cost to UNEP			40,000	



ANNEX III

SUB-COMPONENT: MEXICO

Country	UNITED MEXICAN STATES
Title	Innovative Management Scheme for Retired Refrigerants
Project Duration	18 months
Demonstration Project Budget	US\$ 225,100
Implementing Agency	UNIDO
National Counterpart	National Ozone Unit, SEMARNAT

1. BACKGROUND

Since 2007 SEMARNAT and UNIDO through the National CFC Phase out Plan, have been implementing a program for the installation and operation of a national network of ODS Recovery and Recycling Centers within Mexico. The main goal of the aforementioned program has been to develop national capacities and provide option for the safe recovery, handling and disposal of unwanted CFCs. The retired refrigerants were collected from the end-users, refrigeration service centers refrigeration technicians, manufacturers and distributors, customs and other entities using or handling ODS, primarily CFCs.

A very successful incentive program for retirement of old domestic refrigeration and air conditioning equipment was organized in 2005 by the Fund for Energy Savings (FIDE). This program has accelerated the replacement of old energy intensive appliances with energy efficient ones, resulting in substantial energy savings to the costumers and on national level.

Under this scheme, the Government had been offering to Mexican residents low-interest financing and a cash rebate of up to 50% of the cost of a new, energy-efficient refrigerator, when an old fridge is turned in for recycling. The re-payment is being made through the electric energy bill as a low interest rate loan. Major retailers of new appliances had been delivering the new appliance to the customer and collected the old unit for recycling.



End-of-life fridges collected for recovery of useful materials and safe disposal of hazardous wastes contained in them

The FIDE programme complemented the ongoing Recovery and Recycling programmes financed by the Multilateral Fund and enhanced the reductions in the release of ODS refrigerants. The national recovery and recycling network was enhanced. In addition to the 110 centers equipped through the NPP, 14 new Collection Centers were established in 2007/2008 in 14 regions covering the country. The Collection Centers were equipped with recovery and reclaiming machines, vacuum pumps, refrigerant identifying kits, liquid transfer pumps, recovery cylinders and other tools for recovery of refrigerants from old appliances collected by these centers for safe disposal and recovery of useful materials contained in them.

The personnel of the centers were thoroughly trained both on the operation of equipment and also on vital environmental issues related to the aim of their work.

Two of these fourteen centers are large; one of them is in Mexicali at the northern border on the West coast of Mexico and the other one is in Celaya, located in the center of the country. The rest of the R&R centers are spread over the whole country, none of them nearby the others. The large centers are equipped with state of the art technology employing more than 100 workers; the medium and small size with have in average 15 workers, is also of good standards.

During the first phase of the FIDE programme 604,000 domestic refrigerators and 126,000 air conditioners had been replaced and destroyed.

In 2009 the Mexican Government through the Secretariat of Energy established another very ambitious program to accelerate the domestic refrigerators replacement programme with a target of 1,600,000 pieces to be collected until 2012.

In order to ensure safe disposal of unwanted refrigerants the MLF approved for Mexico a demonstration project on ODS destruction for UNIDO implementation. The aim of the project is to implement a sustainable business model for an efficient ODS waste management system and to focus on the destruction of contaminated CFCs gases collected by the R&R network.



The outputs of the program has been highly satisfactory; the Mexican national network has recovered more than 350 MT ODS, 250 MT have been recycled and reutilized, 77 tons have been destroyed and 65 MT more is waiting for destruction.

2. PROBLEMS

While the project has been operating successfully, the time has arrived to introduce substantial changes in the operation and business model of the ODS refrigerant waste management cycle. The main reasons are as follows:

- i. In Mexico CFC refrigerants have been replaced mainly by HCFC and HFC refrigerants, low-GWP refrigerants are spreading with moderate pace. Currently, only CFC refrigerants are classified as hazardous waste. Recovery, proper handling and safe disposal of HCFCs and HFCs is not mandatory.
- ii. The earlier business model requires fundamental overhaul: FIDE has changed its focus. The replacement of domestic refrigerators ceased and the focus is now on commercial refrigeration equipment. Thus, the financial incentive for collection of large amounts of appliances discontinued. The current level of income is insufficient to maintain the financial interest of the stakeholders.

It is still a general phenomenon that the economic value of refrigerants is not appreciated by the equipment owners – the perception of treating “refrigerant as a consumable” prevails, since the value of refrigerant and the costs associated with the top up of refrigeration equipment in most cases represents a fraction of the running cost of the main business of the owner.

Due to the high cost of collection, treatment, transportation of the second hand refrigerants they could not compete with the relatively cheap virgin refrigerants. Furthermore, there is a very low demand for recovered and/or reclaimed refrigerant because the difference between the price of the virgin refrigerant and the cost of reclaimed ones is insignificant or negative. The high cost of the second-hand refrigerant is caused by the high processing and transportation costs of waste refrigerants in view of the small quantities and many times long distances to the unwanted refrigerant collection centers, which are properly equipped to store, select and collect waste refrigerants to treat or destroy them in economically viable batches. Thus, the demand for recovered refrigerant is marginal; recovery and recycling is becoming an unattractive proposition for the owners and operators of refrigeration equipment.

In this scenario, especially that the FIDE incentives are fading away, the economic benefits in collecting, recycling and reclaiming of used refrigerants are diminishing.

Even if refrigerants are collected, it is technically not possible to re-use or recycle all of it, because a part of the collected refrigerant is tend to be mixed or contaminated (e.g. burnt out compressor etc.). It is becoming very difficult to dispose unwanted refrigerants economically.



Small-scale refrigeration service entities are trying to minimize their cost through purchases of non-standard, off-specification and very cheap refrigerants unaware or without concern of the consequences. Thus, second hand or non-reliable refrigerants easily find their way to the end-users through the non-certified, non-qualified or negligent technicians. After causing damage to the equipment, the off-specification unwanted refrigerant has to be disposed.

As a result, both the cleaned and the mixed refrigerants will be stranded at the recovery, recycling and reclaiming or collection centers who are unable to sell the gases at prices that allow recovery of the high costs associated with the collection, transportation and treatment or disposal. Today, in Mexico the HCFC-22 refrigerant is selling on a very low price and the refrigerant collectors are refusing to take over recovered refrigerants at the former price level. The situation with HFC-134a is better due to its higher price.

Moreover, the Mexican destruction facilities charge large fees for refrigerant destruction.

It is not better internationally, because international transportation and export of many refrigerants require fulfillment of strict conditions and procedures, since they fall internationally under the category of hazardous wastes. Thus the overall cost could be higher and the process is very complicated and time consuming.

All these circumstances constitute a major hindrance and may cause suspension of recovery of unwanted refrigerants. Thus, unless remedial actions are taken urgently, large amounts of refrigerants (especially the cheaper ones) are expected to be released during operation and major repairs or at the end of the lifetime of refrigeration and air-conditioning equipment.

3. PROJECT OBJECTIVE

This subproject will address several issues related to the aim of this global demonstration project:

- i.** Refrigerant containment;
- ii.** Refrigerant quality;
- iii.** Opening avenues for phasing out high GWP refrigerants and introduction of low GWP refrigerants.

The aim of the project is to improve refrigerant containment by extending the useful lifetime of refrigerants and to design an economically viable scheme for treatment and safe disposal of retired refrigerants.

4. STRATEGY AND PROJECT IMPLEMENTATION

The strategy of the project is to apply an integrated “Cradle to Grave” approach tackling all facets of managing retired ODS and other high GWP refrigerants:

- Minimize the amount of refrigerant waste generated;
- Minimize refrigerant losses and venting;
- Raise awareness on the importance and financial benefits of refrigerant containment and the use of clean and good quality refrigerants;



- Create conducive policy environment for improving refrigerant containment and for mandatory safe and sound treatment and disposal of retired refrigerants;
- Create technical and economic conditions enabling appropriate treatment of high GWP substances which will become regulated in A5 countries only on the medium term;
- Improve sustainability of existing refrigerant treatment facilities.
- Disseminate the information collected and demonstrate the outcomes of the project within the Latin American region and also within the country.

4.1. RECLASSIFYING ODS AND HIGH-GWP REFRIGERANTS TO HAZARDOUS WASTE

Currently in Mexico CFC is the only refrigerant type, which is classified as hazardous substance. There are various legislative measures regarding trading, handling, use, disposal etc. for CFC refrigerants. All other ODS and high GWP refrigerants do not fall under these legislations, so their lifecycle is not regulated (except the quota system for production, import and export). In view of this situation the proper handling, recovery, collection, and safe disposal are voluntary and it is done today as a moral obligation or as part of corporate responsibility. This situation cannot be sustained for a longer period of time.

It is proposed to reclassify the ODS and high GWP HFC containing refrigerants into the category of hazardous waste and formulate appropriate legislation on the domestic trade, handling, use, recovery, reclaim and safe disposal of these refrigerants.

Upon implementation of this proposal the following benefits are expected:

- i. All owners of hazardous refrigerants will be obliged to use, handle and dispose safely their refrigerants.
- ii. Recovery, treatment and disposal are associated with high costs, so the owners will pay more attention to proper maintenance and leak prevention, extend the useful lifetime refrigerant to the extent possible through reuse.
- iii. The recovery centers will be able to collect more refrigerants for treatment and disposal, which improve financial viability of their operations through the economies of scales.
- iv. The said increased demand and capacity utilization will partially offset the shortfalls caused by the diminishing FIDE financing.

Budget of Activity 4.1: Reclassifying ODS and High-GWP refrigerants to hazardous waste

3) Item	4) Cost, [USD]
5) National consultant to develop de new regulation	6) 25,000
7) Organization of meetings with stakeholders and authorities	8) 5,000
9) TOTAL	10) 30,000



4.2. OVERARCHING STRATEGY FOR REFRIGERANT WASTE MINIMIZATION

It is recommended to prepare an overarching strategy to handle all refrigerant wastes. This strategy is based on the following considerations:

- i. Refrigerant wastes embody material resources, energy and work. These finite resources and expenses are not to be simply wasted; even if the retired refrigerant is a waste for the refrigeration equipment owner it could represent a useful resource for some other entities.
- ii. Destruction in itself is a costly process nevertheless has a positive environmental impact. Thus destruction should come into play only as a last resort, when no other option is possible.
- iii. Refrigerant waste management is not an isolated process; it is part of the overall refrigerant cycle and should be looked at it in a holistic way. For this the ZERO Leak approach will be considered adjusted to Mexican conditions.

Economic drivers should govern selection and application of the most appropriate waste treatment solution; and the entire process should become self-financing and sustainable. However this might raise questions like governmental subsidies of the process or introducing an environment levy on all types of refrigerants classified as hazardous (currently and after implementation of activity III.b. above). In many countries such approaches work well, but currently, in view of the complexity to add new taxes and financial constraints such or similar enabling actions by now are not possible in Mexico. Nevertheless at least a discussion on this matter and keeping it on the agenda could prove to be useful.

Budget of Activity 4.2: Overarching strategy refrigerant waste minimization

Item	Cost, [USD]
Trials and tests for the recovery of refrigerant and management of wastes. 1,500 appliances @ 15 USD each	22,500
Lab analysis of the recovered refrigerant.	4,500
Coordination	3,000
TOTAL	30,000

4.3. TRAINING AND AWARENESS PROGRAMMES

At least 10 workshops will be organized in different parts of Mexico to inform to the managerial level stakeholders, like major equipment owners and operators, traders and other interested parties on the importance, content and impact of the proposed new legislation; increased responsibilities of owners of refrigerants, new procedures.

The workshop will also include the findings of the Overarching Refrigerant Waste Minimization Strategy.

These issues will be incorporated in the Refrigeration Technicians Training Programme financed through the HPMP targeted to shop-floor level personnel. This approach will minimize the costs and offer better focus for both of the two target groups.



Budget of Activity 4.3: Training and awareness programmes

Item	Cost, [USD]
Ten workshops in different cities within México @ 3,000 each	30,000
Local travels for the organizers	5,000
Material for the workshops	2,000
Coordination of workshops	3,000
TOTAL	40,000

4.4. DISSEMINATION OF EXPERIENCE AND LESSONS LEARNT

A 2 days international workshop and expert group meeting will be organized for technical experts, decision makers including ozone officers, in total 20 participants from the Latin American region to share with the experience and lessons learnt and to demonstrate the functioning of the R&R and destruction scheme adjusted to high-GWP F-gases, this would include a study tour to visit the R&R centers.

Budget of Activity 4.4: Dissemination of experience and lessons learnt

Item	Cost, [USD]
2 Days Workshop in México	9,000
Site visit organization	6,000
International travels	12,000
Local travels for the participants	9,000
Material for the workshop.	6,000
Coordination	3,000
TOTAL	45,000

4.5. UPGRADING TECHNICAL CAPACITY OF SELECTED R&R CENTERS

It is necessary to upgrade the current R&R and Collection centers to meet the new requirement. For demonstration purposes three centers will be selected and equipped with the following set of equipment designed to work with all F-gases.

Budget of Activity 4.5: Upgrading the technical skills of selected R&R centers

Item	Number	Total	Unit Price [USD]	Total Price [USD]
Recovery machine (1 HP)	2	6	1,100	6,600
Refrigerant identifying kit	1	3	6,500	19,500
Recovery Cylinders (1,000 pounds)	2	6	2,000	12,000
Recovery Cylinders (130 pounds)	10	30	300	9,000
Reclaiming machine	1	3	10,000	30,000
Kit for quality check of reclaimed refrigerants (see picture below)	1	3	1,000	3,000
TOTAL				80,100



5. IMPLEMENTATION SCHEDULE

ACTIVITY	TIMEFRAME AFTER APPROVAL					
	Project duration of 18 months					
	1-3	4-6	7-9	10-12	13-15	16-18
Reclassifying ODS and High-GWP refrigerants to hazardous waste						
Selection and designation of expert team. Recruitment of national expert.	█					
Design new legislation		█	█			
Discuss legislation with selected stakeholders from industry government authorities.			█	█		
Approval of legislation				█	█	█
Disseminate information among the stakeholders on the aims and procedures under the new legislation					█	█
Monitoring implementation of the new legislation						█
Overarching strategy refrigerant waste minimization						
Selection and designation of expert team. Recruitment of national expert.	█					
Design the strategy		█	█			
Discuss strategy with selected stakeholders from industry government authorities. Design follow-up actions.			█	█	█	
Disseminate the outcome of the study, implement actions agreed with stakeholders.				█	█	█
Training and awareness programmes						
Preparation of training curriculum				█		
Preparation of training strategy				█		
Identification of potential participants				█	█	█
Delivery of training					█	█
Upgrading the technical skills of selected R&R centers						
Selection of recipient centers	█	█				



Preparation of equipment specification, start bidding process													
Delivery of equipment, training of operating staff													
Use of equipment													
Dissemination of experience and lessons learnt													
Dissemination of information on the results of the Demonstration Workshop within Mexico													
Preparation the programme of the Regional Demonstration Workshop. Identification of participants													
Organization of Regional expert group meeting with site visits													
Closure of project													
Financial closure													
Preparation of Project Completion Report													

6. PROJECT SUSTAINABILITY AND DEMONSTRATION VALUE

On national level, the project is designed to ensure sustainability of existing refrigerant management infrastructure, i.e. R&R and Collection centers. For this, effective policy instrument will be applied.

Enforcement of appropriate treatment or in the worst-case scenario – costly destruction of retired refrigerants - will improve the business environment of treatment and collection facilities.

Raising awareness of owners of refrigeration equipment regarding the cost of their assets and the avoidable cost of waste handling caused by negligent service practices and early “retirement” of refrigerants will also lead to improvements in the levels of refrigerant containment. Highlighting the financial and technical consequences of the use of improper refrigerant would also increase the lifetime of the working fluids and reduce the quantity of refrigerant wastes.

The economic interests of the stakeholders are driving the process, without any longstanding external funding requirement to back all these measures.

Thus, the proposed activities are sustainable themselves and improve the sustainability of the sector.

This demonstration project will be implemented in Mexico only. After evaluation of the results, countries in the Latin American Region could replicate the selected activities according to their conditions and needs. UNIDO and also UNEP using its networking and clearinghouse functions and activities will share the project results globally with other A5 countries.



7. PROJECT BUDGET

The consolidated budget of the project activities is as follows.

TOTAL COST OF THE PROJECT

Activity	Cost [USD]
Reclassifying refrigerants to hazardous waste	30,000
Overarching strategy for refrigerant waste minimization management	30,000
Training and awareness programmes	40,000
Dissemination of experience and lessons learnt	45,000
Upgrading technical capacity of selected R&R centers	80,100
TOTAL	225,100



ANNEX IV

CARRIBEAN SUB-COMPONENT

Country	Regional (Bahamas, Grenada, St. Lucia, St. Vincent and the Grenadines, Suriname)
Title	Safe handling of low-GWP flammable refrigerants
Project Duration	18 months
Demonstration Project Budget	US\$ 220,000
Implementing Agency	UNIDO
National Counterparts	National Ozone Units, National Refrigerant Associations, Vocational Schools

1. BACKGROUND

The phase-out of hydrochlorofluorocarbons (HCFCs), specifically in the refrigeration and air-conditioning sector, has brought about a broader discussion on suitable long-term alternatives. Readily available refrigerant alternatives, which are hydrofluorocarbons (HFCs) e.g. R410A and R407C however, have high global warming potentials (GWPs) and contribute to global warming. The refrigeration and air-conditioning manufacturing sectors worldwide, are thus gearing towards the use of low-GWP alternatives, such as hydrocarbons (HCs) and novel refrigerant formulations of HFO and HFC blends, which are designed to have short atmospheric lifetimes.

Refrigeration service technicians in countries with large service sectors need to be well trained and equipped to cope with the installation and maintenance demands of next-generation appliances. HCs, as well as HFOs, have zero ODP and low-GWP properties; however, both refrigerant groups are flammable. HCs, such as propane, are classed as “A3”-highly flammable. HFOs and HFC blends are classified with A2L flammability – mild flammability with slow propagation. Countries in the Latin-American and Caribbean region (LAC) are gradually beginning to take up hydrocarbons as an alternative to HCFCs in air-conditioning although few technicians are trained to handle the alternatives effectively. It is anticipated that as old installations near decommissioning, more end-users will opt for hydrocarbon-based appliances.

However, specialized training for technicians on flammability needs to be done to ensure that only well-trained technicians service hydrocarbon-based equipment. Hydrocarbons such as propane, LPG and hydrocarbon mixtures have been used during service operations, where the risks associated with the flammability and the thermodynamically properties of the refrigerants has not always been taken into account. Hence it is important to increase the know-how and confidence of technicians with regard to using flammable low-GWP refrigerants when installing new units or servicing old units.



2. PROJECT OBJECTIVES

In order to facilitate the introduction of low-GWP refrigerants in the servicing sector, this demonstration project aims to

- (i) Enhance the expertise of technicians and train specialized trainers,
- (ii) Upgrade the training curricula at vocational centers,
- (iii) Augment the equipment at the regional training center and
- (iv) Expose stakeholders to the latest HC-based equipment and components on the market.

The planned activities under the project are linked to the countries' respective HPMPs. The use of flammable refrigerant alternatives is covered to varying extents in the HPMPs, as described in Section 3.2 below. However, the funding levels of the HPMPs cannot adequately cover the issue of flammability. Therefore, regional, as well as country-specific activities are required to bring about a more comprehensive approach that would enable the countries to transition to flammable low-GWP refrigerants in a safe manner, as proposed in the project and described in more details below. Moreover, it is vital that these activities are carried out as soon as possible, so that current HC service practices are conducted safely, in light of the concerns pointed out under ExCom Decision 72/17.

3. PROJECT STRATEGY & LINKAGE

3.1 Strategy

The project will achieve its objectives through activities implemented at regional and country-levels with results replicated in the respective HPMPs of the countries. Technicians who are already adequately trained in refrigeration and air-conditioning servicing practices will be targeted to ensure a high level of expertise in handling flammable refrigerants is attained after training. To ensure continuity of the specialised training, the curricula of the training programmes will be upgraded during the workshop to reflect best practices in handling flammable refrigerants. To benefit from their expertise in the area of hydrocarbons, UNIDO will seek input from GIZ in the preparation of the training workshop and its curriculum.

3.2 HPMP linkage

The use of flammable alternatives especially hydrocarbons is considered in different ways in the respective HPMPs of the countries involved in this demonstration project. However, a more comprehensive approach is needed that will really facilitate a more effective transition to flammable low-GWP alternatives. The results of this demonstration project will be introduced into the HPMPs to achieve a more effective programme on hydrocarbons. The extent to which hydrocarbons are addressed in the respective HPMPs is outlined below.



a. The Bahamas

The Refrigeration Service Engineers and Society (RSES) and the Bahamas Technical and Vocational Institute offer universal certification and specialized training on a regular basis. Under Stage I of the HPMP, RSES conducted 4 six-week training classes for 60 technicians on R410A for students across different islands in the Bahamas. Toolkits were purchased and distributed (leak detectors for flammable refrigerants and HC manifold gauges were included in these). The current training programme, training facility and toolkits are most suited for R410A (a high pressure refrigerant).

b. Grenada

Stage I of the HPMP includes training and certification of technicians on good practices, wherein a demonstration component was added to show how HCFC R&A/C equipment can be converted to non-HCFC. Due to the prevalence of R410A as a feasible alternative to HCFC-22, the activities under Stage I are focused on its use. However, as hydrocarbons are increasingly being used in the country, necessary upgrades have to be in place to facilitate the move to flammable low-GWP alternatives.

c. St. Lucia

Under Stage I of the HPMP, the main training center at the Sir Arthur Lewis Community College in Castries, and a small training center in Anse La Raye were equipped with refrigerant recovery and servicing tools, no equipment specific to training on flammable refrigerants was provided. After completing the certified training courses at these centers, technicians were provided with toolkits (leak detectors with flammable refrigerant toolkits were included in these).

d. St. Vincent and the Grenadines

Unlike the other countries participating in the project, the HPMP on St. Vincent and the Grenadines is based on a single-stage approach to achieve complete phase-out of HCFCs by 2020 with a 2.5% servicing tail to 2025. Tools and equipment were provided to training centers and service workshops, these included charging stations and manifold gauges and leak detectors suitable for flammable refrigerants as well as flammable gas labels. Training for technicians also included the handling of hydrocarbon refrigerants.

e. Suriname

The NOU and the Air-conditioning, Refrigeration & Ventilation Association Suriname (ARVAS) established a training programme in line with the guidelines set by the Caribbean Vocational Quality (CVQ) Standards. As of May 2013, all local technicians and members from ARVAS have gone through the training. Training of technicians on HCFC alternatives, R407C and R410A has been conducted. Toolkits were purchased and distributed for technicians who have completed the course; these toolkits did not contain any HC, flammable- specific equipment. In addition to the ARVAS training, two Cuban trainers were invited in October 2013 to train 55 local technicians and ARVAS members on hydrocarbon technology.



4. PROJECT IMPLEMENTATION

4.1 Planned outputs and activities

- a. Pilot training center equipped in **Grenada**, the lead pilot country

In order to facilitate the introduction and the safe use of low-GWP refrigerants, the demonstration project aims to establish a pilot training center at the T. A. Marryshow Community College in Tanteen, St. George's and provide the necessary equipment and tools such as, brazing installations, R-290 demonstration units (split room A/C), hydrocarbon specific tools and toolkits, etc. This component will also address safety issues at the training site such as ventilation.

- b. “Train the trainers” regional workshop - **Grenada**

5-day workshop will be hosted at the pilot training center. Association representatives and nominated trainers from existing vocational training institutions will be invited to the regional workshop. Trainers will be certified on flammable refrigerants and related technology, and will receive theoretical and hands-on training.

- c. Training & certification curriculum upgraded

One trainer from each country, who is responsible for setting the training curricula for refrigeration and air-conditioning, will also be invited to the workshop. A single curriculum designed specifically for training on flammable refrigerants will be developed and adopted by all participating countries.

- d. Regional technology exhibition organized - **Grenada**

Regional suppliers and distributors of flammable RAC components and safety devices will be invited to showcase their equipment at a 1-day exhibition held concurrently with the regional “Train the trainers” workshop in Grenada.

- e. Training of technicians

One training session per country will be held to train and certify technicians on handling flammable refrigerants and to implement the adopted curriculum.

- f. Regional expert group meeting on Evaluation and dissemination of project results - **St. Vincent & the Grenadines.**

The goal of the regional expert group meeting is to:

- Fine-tune the regional curriculum for training on flammable refrigerants based on lessons learned;



- Disseminate the project results and lessons learned to the representatives of the beneficiary countries;
- The results of the project will be shared with other countries, specifically in the LAC and AFR regions in the form of a report and videos in order to provide recommendations for future replication under Stage II HPMPs.

4.2 Expected outcomes

- a. Increased know-how and confidence in the use of flammable refrigerants during service operations.
 - Trainers and service technicians trained on installation and servicing A/Cs charged with flammable refrigerants, and handling of flammable refrigerants safely.
 - Vocation center curricula upgraded.
 - Equipment at pilot training centre upgraded.

- b. Introduction of new low-GWP technologies facilitated in respective countries and region.
 - Activities of demonstration project are linked to respective HPMPs.
 - Sustainable interventions on flammable refrigerants assessed (e.g. costs, availability of refrigerants, components, as well as final products, and other resources).
 - Activities replicated in other countries in the region.

5. ACTIVITIES TIMELINE

Outputs	1-6 Months	7-12 Months	13-18 Months
Pilot training centre equipped in Grenada			
“Train the trainers” regional workshop conducted			
Curriculum on flammable refrigerants upgraded			
Regional technology exhibition organized			
Training of Technicians conducted			
Regional expert group meeting organized & Evaluation and dissemination of project results			



6. PROJECT SUSTAINABILITY AND DEMONSTRATION VALUE

Although flammability concerns are addressed to varying extents in the respective HPMPs, the level of funding available cannot adequately cover all the issues. Training workshops for technicians are usually of a short duration and cannot deliver the high level of expertise needed by the region to ensure safe practices when using flammable refrigerants. In addition, since there is free movement of persons and skills in the Caribbean Community (CARICOM), adopting a regional curriculum for training on flammability, will ensure that when technicians move from one Caribbean country to the other, they are well trained and aware of safety issues when handling refrigerants. A common complaint from countries in the region is a lack of suppliers and distributors for the region to facilitate the entry of hydrocarbon-based equipment, components and refrigerants.

Taking into account the above constraints, this project will demonstrate the following:

- Hydrocarbon refrigerants are effective, viable and suitable replacement alternatives to ODSs and F-Gases mitigating their inherent direct and indirect climate impact (TEWI),
- Deployment of new hydrocarbon technologies can be quickly facilitated through specialised training for technicians and through exposure to suppliers and distributors.
- Regional approach to specialised training - especially in LVCs - can achieve cost savings for training programmes in the service sector and ensure a uniform level of expertise on flammable refrigerants across the region.

The results of the project such as the trainings and curriculum will help develop public awareness and support educational activities while they can be incorporated in the HPMP strategies of the participating countries.

Through replication of the results in the various HPMPs, the sustainability of the project will be ensured. It is hoped that after dissemination of the results, they will be deployed in the HPMPs of all CARICOM countries, to ensure that when there is movement of technicians across the borders, they have the requisite training needed if they want to handle flammable refrigerants.



7. PROJECT BUDGET

Item	Countries	Activities	Description/ Remark	Cost breakdown [US\$]	Total costs [US\$]	Agency
Design of training curriculum preparation and monitoring of training	All	- Develop training material, curriculum and training activities - Carry out training and assessment of trainers during regional workshop - Evaluate the training and certification programme - Participate at the expert group meeting	Involvement of International expert	30,000 (including travel)	30,000	UNIDO
Upgrading Training Centre	Grenada	Purchase and Delivery of tools	Hydrocarbon-specific tools and equipment for training centre	66,000	66,000	UNIDO
Train the trainers Regional Workshop	All	Training in Grenada with the participation of regional stakeholders	12 participants	3, 250 per participant (including travel)	39,000	UNIDO
Workshop & Exhibition	Grenada	Organise workshop and exhibition	Hall hire and Logistics		5,000	UNIDO
Training Sessions for Technicians	All	-Hire trainers -Training in all countries	Training x 5 countries	9,000 x 5	45,000	UNIDO
Regional Expert Group Meeting, Dissemination of Results	All	-Prepare videos and report -Organise expert group meeting			35,000	UNIDO
TOTAL					220,000	



ANNEX V

EAST-AFRICAN SUB-COMPONENT

Country	Regional (Eritrea, Kenya, Tanzania, Uganda, Zambia)
Title	Standards and Market Availability of Quality Refrigerants
Project Duration	18 months
Demonstration Project Budget	US\$ 210,000
Implementing Agency	UNIDO Lead- & UNEP Co-Implementing Agency
National Counterparts	National Ozone Units

1. BACKGROUND

East Africa's countries are one of the fastest growing economic hubs of the continent with a population of approximately 165 million.

Refrigerant supply is growing in line with the demand due to the increasing number of comfort, industrial and commercial equipment. However, low quality refrigerants of various sources and origins are finding their ways to the domestic market. This negatively affects not only the whole refrigerant market, but it also has become one of the major concerns and a serious obstacle to the development of the refrigeration-servicing sector. Contaminated, mixed or recovered refrigerants can lead to decreased cooling capacity and energy efficiency, reduced lifetime, increased servicing needs, they can damage the compressor of the equipment and end up being vented to the atmosphere.

All of the target countries are Low-Volume Consuming Article 5 countries, where the refrigerant market is small with loose standards, so low-quality substances can easily and quickly spread. Moreover, since the countries of the region have strong economic and commercial connections, refrigerants can easily cross borders. It is particularly true for Kenya, Tanzania and Uganda, where the Common Market and the Customs Union of the East African Community allow the free trade and movement of goods and services.³

The predominant HCFC consumed in the region is **HCFC-22** which is solely used in the refrigeration and air-conditioning servicing sector. The complex issue of low-quality refrigerants (recovered, mixed) should be addressed in the first place in order to enhance the technical level of the servicing sector. For this it is necessary to use policy instruments, monitoring mechanisms and raising awareness of dealers, technicians and end-users.

³ East African Community member states: Republics of Burundi, Kenya, Rwanda, the United Republic of Tanzania, and the Republic of Uganda. The Common Market and the Customs Union are in force since 2010.



The root of the problem is that the purity of virgin refrigerant is questioned neither by the importers nor by the end-users. Most technicians assume that the refrigerant in the cylinder is "good enough" until the RAC system develops failures or cooling problems. Furthermore, even if a technician suspects the refrigerant is somehow contaminated, there is no proper mechanism/strategy to detect or avoid low-quality refrigerants.

In order to phase out HCFC-22, all the target countries work on their ongoing HCFC Phase-out Management Plan (HPMP): in Eritrea, Tanzania, Uganda and Zambia the HPMPs are being implemented by UNEP and UNIDO; in Kenya by the Government of France.

The present proposal fits into the concept of the ongoing HPMPs: it would benefit from the established network of stakeholders and the experience gained so far. At the same time it would give new impetus to improve efficiency and impact of the HPMP by extending its scope of activities and widening the group of stakeholders.

2. PROJECT OBJECTIVES

The objective of the project is to facilitate safer and more efficient operation of equipment in the RAC sector through the improved availability of appropriate quality refrigerants.

The objective is to be reached with a set of activities targeting the quality assurance of refrigerants through the strengthening of certification and monitoring mechanisms and raising awareness of stakeholders.

3. PROJECT STRATEGY

Due to the nature of the demonstration project and the common characteristics of the target countries, the selection of a **lead pilot country** is suggested. While most of the activities will target all beneficiary countries, many of the activities will be implemented in the pilot country. This will allow the demonstration and monitoring of the project results on the country level, while ensuring that the experience and lessons learned are shared on a regional level offering the potential for regional replications.

Based on the findings of the PRP activities and the experience and lessons learned gained during the implementation of HCFC Phase-out Management Plans, **the United Republic of Tanzania** is selected as the lead pilot country.

Tanzania is the biggest by size and population among the target countries. She is well endowed with international shipping infrastructure; has the second longest coast line⁴. These factors allow intense import of goods, including refrigerants, from overseas. Since there is no HCFC production capacity in the region and Tanzania is the entry point to East Africa for the majority of refrigerants, national interventions can have significant effect on the regional market and particularly on the East African Community. Therefore, all the target countries will strongly benefit from the project.

Stage I of the HCFC Phase-out Management Plan of Tanzania has been implemented since 2012. The activities under the first tranche had been successfully completed. These included

⁴ Eritrea has the longest coast lines among the beneficiary countries of the project.



updating of training curricular, training of customs officers and technicians and provision of tools and equipment to recovery, recycling and retrofitting centres. The second tranche is to be submitted to the 76th ExCom in March 2016.

The project proposal will rely on and complement the achievements of HPMP Stage I, while the lessons learnt will largely contribute to the objectives of HPMP Stage II and could also be integrated in the HPMPs of other countries.

4. PROJECT IMPLEMENTATION

The project is composed of three components: Policy, Technical Assistance and Awareness Raising. The activities will be carried out with the support of international and national experts and with the strong involvement of the national authorities, including the National Ozone Unit.

4.1 Policy Component

This Component focuses on the **detailed assessment of the current national policy frameworks, level of human resources and available equipment / tools.**

4.1.1 National assessment of the refrigerant markets

The following main aspects will be examined in all the beneficiary countries: the source and presence of fake, mixed and / or recovered refrigerants, mislabels / misleading information on containers / cylinders. A detailed gap analysis will also be carried out on control mechanisms in the local as well as in the regional context and on the monitoring tools / equipment currently available in the countries. The assessments will be carried out by national experts hired in each country.

4.1.2 Establishment of the Technical Advisory Group

The Technical Advisory Group (TAG) will serve as a platform to exchange opinions and share ideas. It will be composed of the responsible officers of the implementing agencies, international experts and the representatives of the academia and the private sector. Furthermore, it will involve representatives of international standards bodies, like the East African Standards Committee (EASC), ISO and the American Society of Heating, Refrigerating and Air Conditioning Engineers (AHSRAE). The TAG will evaluate the results, synthesize national assessments and share the information with relevant national and regional authorities. It will propose technical aspects related to the revision of national standards on refrigerants and their safe handling in light of the identified national needs. In connection with the Technical Assistance Component, it will give advice on the preparation of training materials and training activities and the design and establishment of the Mobile Refrigerant Testing Service in Tanzania as per 4.2.3. In addition, the TAG will closely monitor the operation of the Testing Service and evaluate the lessons learnt.



4.2 Technical Assistance Component

The Technical Assistance Component will provide technical support to the beneficiary countries in terms of **tools and equipment, training activities and the design and establishment of a refrigerant quality certification and monitoring scheme** in the lead pilot country in cooperation with the NOU and the Natural Bureau of Standard⁵. The focus will be on the availability of testing services and quality assurance especially when buying from importers and in-country re-sellers. The approach will be implemented **hand-in-hand with the AHRI-UNEP Refrigerant Driving License initiative**, with specific focus on the establishment of an enforcement scheme including penalties. The operation of the scheme will be closely followed and monitored by the IAs who shall build/strengthen local associations (UNEP-ASHRAE cooperation). While some activities will be implemented in all the beneficiary countries, some will concentrate on the lead pilot country, Tanzania.

All countries

4.2.1 Delivery of tools

Supply of monitoring aids and tools, e.g. refrigerant identifiers based on the findings of the national assessment carried out under the Policy Component. The tools will be used by the environmental inspectors who will carry out the refrigerant quality control as per 4.2.3.

4.2.2 Training activities

Beside the use of the monitoring tools, the training activities will focus on the importance of refrigerant quality and testing and the administration of the quality labeling system. The training will take place in Tanzania; however, participants from all the beneficiary countries will be invited to join. The training will target the staff of NOUs, refrigerant importers, in-country sellers and environmental inspectors.

Tanzania

4.2.3 Design and establishment of the Mobile Refrigerant Testing Service

The service will be composed of environmental inspectors equipped with mobile testing devices and will be focused on refrigerant importers and in-country sellers. The environmental inspectors who attended the training and are certified members of the Mobile Refrigerant Testing Service will conduct the testing at the importers and the in-country sellers all over the country.

⁵ Tanzania Bureau of Standards: <http://www.tbs.go.tz/standards/>



4.2.4 Design and establishment of the labeling system, including the update/introduction of local refrigerants and refrigerant container standards and guidelines.

This labeling will be used to indicate the quality of the refrigerant and records its inspection by the Mobile Refrigerant Testing Service. The labels for tested refrigerants should be designed with some clear pictograms to ensure clear communication with all stakeholders.

4.2.5 Empowering local institutions and consumer protection bodies and establishing the monitoring scheme

Identified national authorities, the NOU and the national expert will be responsible for the monitoring of the performance of the mobile testing service and labeling scheme in Tanzania. Reaching out to local stakeholders and enabling them to act as focal points of the management of the Testing Service is crucial in order to ensure the long-term sustainability of the concept.

4.3 Awareness Raising Component

This Component is designed to improve awareness of stakeholders regarding the importance of refrigerants' quality and its relationship with the efficiency of equipment. Outreach must be carried out **to develop interest and understanding as well as to build up credibility and trust in the labeling system**. The awareness raising activities will take place in Tanzania as well as in the other beneficiary countries.

4.3.1 Outreach campaign

The NOUs and environmental inspectors will be enabled to provide information to end-users, importers and re-sellers on the benefits of not contaminated and reliable quality refrigerants, which includes maintaining efficiency and trouble-free reliable operation of refrigeration equipment.

The labeling system will be advertised in all the beneficiary countries to ensure that quality refrigerants are recognized in the region.

4.3.2 Collection and evaluation of lessons learnt

The results from the project will be assessed and compiled with the aim of replicating the strategy in the region as part for the Stage II HPMPs. Furthermore, the findings will be also integrated in the awareness raising campaign.



5. ACTIVITIES TIMELINE

Components	Activities	Countries involved	1-6 Months						7-12 Months						13-18 Months										
Policy	National assessments of the refrigerant markets	Eritrea, Kenya, Tanzania, Uganda, Zambia	■	■	■																				
	Delivery of tools	Eritrea, Kenya, Tanzania, Uganda, Zambia							■	■	■														
Technical Assistance	Regional training in Tanzania	Eritrea, Kenya, Tanzania, Uganda, Zambia																							
	Design and establishment of the Mobile Refrigerant Testing Service	Tanzania																							
	Design and establishment of the labeling system, including the update/introduction of local standards and guidelines on refrigerants and refrigerant containers	Tanzania																							
	Empowering local institutions and consumer protection bodies and establishment of the monitoring scheme	Eritrea, Kenya, Tanzania, Uganda, Zambia																							
Awareness Raising	Outreach campaign	Eritrea, Kenya, Tanzania, Uganda, Zambia																							
	Collection and evaluation of lessons learnt	Eritrea, Kenya, Tanzania, Uganda, Zambia																							



6. PROJECT SUSTAINABILITY AND DEMONSTRATION VALUE

The project proposal will provide an additional boost for the controlled use and phase-out of HCFCs. As mentioned earlier, it will complement Stage I of HPMPs and will serve as basis for Stage II HPMPs. Moreover, the project activities will pave the way and **prepare the ground for the introduction of low global warming potential refrigerants**, where quality is not an option but a must.

The establishment of quality standards and certification scheme, the identification of trusted dealers/re-sellers, the training of involved stakeholders including environmental inspectors are assets that will **largely contribute to the success of any future interventions**.

This demonstration project would be **pioneering in the involvement of stakeholders that until now have never participated in MP activities: refrigerant importers and in-country dealers**.

Although some of the activities under the Technical Assistance Component will be implemented in Tanzania only, all the target countries will directly benefit. Since Tanzania is the entry point of refrigerants to East Africa, it is expected that as a result of the project the reliability of the **quality of refrigerant will increase in the whole region**. In addition, since all the countries will be involved in the key project activities, later on it will be easy to implement the “missing parts” and complete the national interventions based on the experience in Tanzania. This provides the concept with a **unique possibility for replication in the region**, but it should also be viable in any other beneficiary countries.



7. PROJECT BUDGET

Item	Country	Activities	Description/ Remark	Cost breakdown [US\$]	Total costs [US\$]	Agency
National Assessment, Gap Analysis	Eritrea, Kenya, Uganda, Zambia	<ul style="list-style-type: none"> - National assessments and detailed gap analysis carried out - Participation in the work of the TAG and the EGM - Participation at the regional training programme 	One national expert per country including travel costs	4 x 5,000 (including travel)	20,000	UNIDO
National Assessment, Gap Analysis, Coordination of activities, setting up Testing Service and Labeling scheme	Tanzania	<ul style="list-style-type: none"> - National assessment and detailed gap analysis carried out - Participation in the organization of the TAG Meeting and the EGM - Organize and participate in the regional training - Participate in the design and establishment of the Mobile Refrigerant Testing Service - Participate in the design and establishment of the refrigerants labeling system - Monitor the operation of the Testing Service and its effect on the national refrigerant market - Assess and evaluate results 	One national expert including travel costs	Including travel	10,000	UNIDO
Technical Advisory Group	All	Provide advice on <ul style="list-style-type: none"> - evaluation and synthetization of national assessment reports - training material and training activities - design of the Mobile Refrigerant Testing Service in Tanzania and participate in the monitoring of its operation - evaluation of lessons learnt 		Including travel	35,000	UNIDO
Equipping and Training of Stakeholders	All	Delivery of tools	1 set refrigerant identifier per country and monitoring aids and tools based on the findings of the national assessments		40,000	UNIDO
	All	Training in Tanzania with the participation of regional stakeholders	<ul style="list-style-type: none"> - Benefiting of RDL - 20 participants 		25,000	UNIDO



Demonstration Project on Refrigerant Quality, Containment and Introduction of Low GWP Alternatives

Item	Country	Activities	Description/ Remark	Cost breakdown [US\$]	Total costs [US\$]	Agency
Mobile Refrigerant Testing Service, Labeling Scheme	Tanzania	Design, establishment and monitoring of the Mobile Refrigerant Testing Service	Service composed of environmental inspectors equipped with mobile testing devices		25,000	UNIDO
	Tanzania	Design and establishment of the labeling system, including the update/ introduction of local standards and guidelines for refrigerants / containers	Labeling of quality and inspections		25,000	UNEP
	Tanzania	Empowering local institutions and consumer protection bodies and building the monitoring scheme	Building/strengthening local association (UNEP-ASHRAE cooperation)		10,000	UNEP
Awareness Raising	All	Outreach campaign & Information sharing regionally and globally			20,000	UNEP
TOTAL					210,000	