



**Программа Организации
Объединенных Наций по
окружающей среде**



Distr.
GENERAL

UNEP/OzL.Pro/ExCom/76/28
14 April 2016

RUSSIAN
ORIGINAL: ENGLISH

ИСПОЛНИТЕЛЬНЫЙ КОМИТЕТ
МНОГОСТОРОННЕГО ФОНДА ДЛЯ
ОСУЩЕСТВЛЕНИЯ МОНРЕАЛЬСКОГО ПРОТОКОЛА
Семьдесят шестое совещание
Монреаль, 9-13 мая 2016 года

ПРОЕКТНОЕ ПРЕДЛОЖЕНИЕ: КОСТА-РИКА

Настоящий документ содержит замечания и рекомендации Секретариата по следующему проектному предложению:

Холодильная промышленность

- Демонстрационный проект по применению холодильной системы, работающей на хладагентах аммиак/диоксид углерода, для замены ГХФУ-22 на производственном предприятии среднего бизнеса и в магазине розничной торговли компании Premezclas Industriales S.A. в Коста-Рике

ПРООН

ОЦЕНОЧНЫЙ ЛИСТ ПРОЕКТА — НЕ МНОГОЛЕТНИЕ ПРОЕКТЫ

РЕСПУБЛИКА КОСТА-РИКА

НАЗВАНИЕ ПРОЕКТА (-ОВ)

ДВУСТОРОННЕЕ УЧРЕЖДЕНИЕ /
УЧРЕЖДЕНИЕ-ИСПОЛНИТЕЛЬ

(a) Демонстрационный проект по применению холодильной системы на хладагентах аммиак/диоксид углерода для замены ГХФУ-22 на производственном предприятии среднего бизнеса и в магазине розничной торговли компании Premezclas Industriales S.A. в Коста-Рике	ПРООН
---	-------

НАЦИОНАЛЬНОЕ КООРДИНИРУЮЩЕЕ УЧРЕЖДЕНИЕ:

Национальный орган по озону

ПОСЛЕДНИЕ ПРЕДСТАВЛЕННЫЕ ДАННЫЕ О ПОТРЕБЛЕНИИ ОРВ, УКАЗАННЫХ В ПРОЕКТЕ

А: ДАННЫЕ ПО СТАТЬЕ 7 (ТОНН ОРС ЗА 2014 ГОД, ПО СОСТОЯНИЮ НА АПРЕЛЬ 2016)

ГХФУ	12,63
------	-------

В: ДАННЫЕ СТРАНОВОЙ ПРОГРАММЫ ПО СЕКТОРАМ (ТОНН ОРС ЗА 2015 ГОД, ПО СОСТОЯНИЮ НА АПРЕЛЬ 2016)

ГХФУ-22	8,56
ГХФУ-141b	2,19
ГХФУ-141b в составе импортируемых готовых полиоловых смесей	1,10
ГХФУ-142b	0,14
ГХФУ-123	0,05
ГХФУ-124	0,01
ГХФУ-225ca	0,05
ГХФУ-225cb	0,07

Оставшийся объем потребления ГХФУ, отвечающий критериям финансирования (тонн ОРС)

9,17

АССИГНОВАНИЯ ПО БИЗНЕС-ПЛАНУ НА ТЕКУЩИЙ ГОД	Финансирование (долл. США)	Объемы поэтапного отказа (тонн ОРС)
(a)	500 000	0,00

НАИМЕНОВАНИЕ ПРОЕКТА:	
Применение ОРВ на предприятии (тонн ОРС):	0,035
ОРВ, подлежащие выводу из обращения (тонн ОРС):	0,035
ОРВ, подлежащие вводу в обращение (тонн ОРС):	0
Продолжительность проекта (в месяцах):	14
Первоначально заявленная сумма (долл. США):	590 000
Конечная стоимость проекта (долл. США):	
Дополнительные капитальные затраты:	524 000
Непредвиденные расходы (10 %):	0
Дополнительные эксплуатационные расходы:	0
Общая стоимость проекта:	524 000
Участие на местном уровне (%):	100
Экспортная составляющая (%):	0
Запрашиваемый грант (долл. США):	524 000
Эффективность затрат (долл. США/кг):	н/п
Административные расходы учреждения-исполнителя (долл. США):	36 680
Всего стоимость проекта за счет Многостороннего фонда (долл. США):	560 680
Статус встречного финансирования (да/нет):	Да
Этапы мониторинга проекта включены (да/нет):	Да

РЕКОМЕНДАЦИЯ СЕКРЕТАРИАТА

Для рассмотрения в индивидуальном порядке

ОПИСАНИЕ ПРОЕКТА

1. От имени правительства Коста-Рики, ПРООН в качестве назначенного учреждения-исполнителя представила на 76-м совещании заявку на финансирование демонстрационного проекта по применению холодильной системы с использованием аммиака/диоксида углерода (R-717/R-744) для замены торгового холодильного оборудования, работающего на ГХФУ-22, в розничном магазине компании Premezclas Industriales S.A. в Коста-Рике в сумме 590 000 долл. США плюс административные расходы учреждения в сумме 41 300 долл. США, согласно первоначально представленной заявке¹. Проектная заявка содержится в Приложении I к настоящему документу.

Цель проекта

2. Потребление ГХФУ в Коста-Рике в 2015 году составляло 185,45 метрических тонн (мт) (12,18 тонн ОРС) в секторе техобслуживания и сборки холодильного оборудования и оборудования кондиционирования воздуха. Часть потребляемых объемов использовалась для заправки новых установок промышленного и торгового холодильного оборудования. Несмотря на предпринимаемые правительством усилия по внедрению натуральных хладагентов с низким потенциалом глобального потепления (ПГП), имеются достаточно серьезные препятствия для внедрения таких технологий в коммерческих масштабах. Поэтому в качестве промежуточного варианта для замены ГХФУ в подсекторе сборки промышленного и торгового холодильного оборудования и оборудования кондиционирования воздуха применяются ГФУ, поскольку низкочувствительные и технологически зрелые решения с их использованием представлены на рынке. Исходя из этого, разработан проект для демонстрации возможности использования в розничных магазинах двухступенчатой холодильной системы с хладагентами R-717/R-744 в качестве эффективной альтернативы для замены систем, работающих на ГХФУ-22.

3. Предприятие-участник — компания Premezclas Industriales de Panadería S.A. (Premezclas) использует холодильную установку производительностью 50 тонн для хранения продуктов питания, имеющую центральный блок с двумя компрессорами спирального типа и 14 теплообменников на хладагенте ГХФУ-22, с объемом заправляемого хладагента 909 кг. Предлагаемая система позволит уменьшить рабочее давление и расходы по вторичному контуру, а также объем заправляемого хладагента R-717, что снизит риски для здоровья и безопасности на производстве.

4. В 2015 году для заправки системы было использовано 0,64 мт ГХФУ-22. В рамках демонстрационного проекта предприятие обязалось поэтапно свести это потребление к нулю (от компании Premezclas получено письменное обязательство).

Реализация проекта

5. В рамках демонстрационного проекта будет разработана и смонтирована новая двухступенчатая холодильная система с использованием R-717 в качестве первичного хладагента и R-744 — в качестве хладоносителя теплообменника; будут проведены испытания системы для оценки ее производительности и энергоэффективности в сравнении с системой, работающей на ГХФУ-22; и будет проведено обучение инженеров и технических специалистов. Собранные информация будет использована для разработки стандартов и инструкций по проектированию, монтажу и эксплуатации систем с хладагентами R-717/R-744 в странах с такими же

¹ Было одобрено выделение финансирования для подготовки данного проекта в размере 40 000 долл. США плюс административные расходы учреждения в размере 2 800 долл. США, при том понимании, что полученное одобрение не отменяет необходимости утверждения проекта или его объемов финансирования в процессе рассмотрения представленных заявок (решение 74/26).

климатическими условиями, как в Коста-Рике. Демонстрационный проект также обеспечит обучение инженеров и технических специалистов, которые будут расширять внедрение подобных систем на своих предприятиях.

Бюджет проекта

6. Общая сумма затрат по проекту оценивается в 1 020 095 долл. США, из них 590 000 долл. США по текущей заявке запрашивается у Многостороннего фонда, а остальные 430 095 долл. США должны быть предоставлены софинансирующим предприятием, как показано в таблице 1.

Таблица 1. Расходы по проекту с разбивкой по видам деятельности (в долл. США)

Компонент	Описание	Запрашиваемое финансирование	Софинансирование	Всего
Оборудование и процесс реконверсии	Оборудование	344 000	234 245	579 245
	Демередж (время простоя) и поставка оборудования	-	17 529	17 529
	Общестроительные работы	-	43 206	43 206
	Сборка, монтаж и ввод в эксплуатацию	100 000	91 348	191 348
	Регистрация инженерных изысканий	-	13 266	13 266
	Непредвиденные расходы	30 500	29 500	60 000
Итого по компоненту		474 500	430 095	904 595
Техническая поддержка	Международный эксперт	30 000	-	30 000
	Национальный эксперт	25 000	-	25 000
	Разработка нормативных положений и стандартов	15 000	-	15 000
	Развитие потенциала (обучение кадров)	25 000	-	25 000
	Семинар по завершении проекта	10 000	-	10 000
	Непредвиденные расходы	10 500	-	10 500
Итого по компоненту		115 500	-	115 500
Общий объем затрат		590 000	430 095	1 020 095

7. Координацию проекта будет обеспечивать национальный орган по озону (НОО) при содействии ПРООН. Проект планируется завершить через 14 месяцев.

ЗАМЕЧАНИЯ И РЕКОМЕНДАЦИИ СЕКРЕТАРИАТА

ЗАМЕЧАНИЯ

8. Установка двухступенчатой холодильной системы с хладагентами R-717/R-744 проводилась многонациональной корпорацией (Unilever) в одной из стран Латинской Америки; однако информации об оценке эффективности этой системы пока нет. Поэтому предлагаемый демонстрационный проект расширит знания о двухступенчатых холодильных системах с хладагентами R-717/R-744, что позволит сделать следующий шаг в развитии технологий. Проект может быть использован для замены холодильных установок, работающих на ГХФУ-22; он будет способствовать разработке инструкций и стандартов, поможет найти поставщиков запчастей и компонентов, и поможет устранить технические и логистические барьеры для внедрения данной технологии.

9. К потенциальным рискам и препятствиям, которые могут помешать успешному применению данной технологии, относятся: высокие затраты, связанные с ее применением; дефицит информации, отсутствие поставщика компонентов, отсутствие у инженеров и технических специалистов необходимых технических навыков и ноу-хау. Планируется, что эти риски, связанные с внедрением предлагаемой технологии, можно будет минимизировать в рамках

проекта за счет передачи технологий, обучения кадров и предоставления поддержки для формирования цепочки поставок.

10. В свете решения 74/21(с), секретариат предложил ПРООН рассмотреть возможности для наиболее рационального распределения затрат по данному демонстрационному проекту. В ответ на запрос ПРООН скорректировала сумму затрат по проекту, удалив такие статьи расходов, как разработка нормативных положений и стандартов (15 000 долл. США); семинар после завершения проекта (10 000 долл. США); и непредвиденные расходы (41 000 долл. США). В итоге стоимость проектных расходов в заявке на финансирование от Многостороннего фонда составляет 524 000 долл. США плюс административные расходы учреждения.

Выводы

11. Демонстрационный проект связан с выполнением мероприятий по поэтапному отказу, предлагаемых в рамках ПОДПО для Коста-Рики. В случае успешной реализации проекта он представит практически применимую технологию с низким ППП для замены оборудования, работающего на ГХФУ-22, которое используется в супермаркетах и холодильных установках для хранения продукции, при этом у новой системы охлаждения есть потенциал для повышения эффективности энергосберегающих технологий.

РЕКОМЕНДАЦИЯ

12. Исполнительный комитет может рассмотреть возможность принятия следующих решений:
- (a) Рассмотреть демонстрационный проект по применению холодильной системы, работающей на хладагентах аммиак/диоксид углерода (R-717 / R-744), для замены ГХФУ-22 в магазине розничной торговли компании Premezclas Industriales S.A., в контексте своего обсуждения заявок по демонстрационным проектам для внедрения альтернативных технологий с низким потенциалом глобального потепления вместо ГХФУ, как указано в документе по общему обзору вопросов, намеченных в ходе пересмотра проектов (UNEP/OzL.Pro/ExCom/76/12);
 - (b) Одобрить демонстрационный проект по применению холодильной системы, работающей на хладагентах аммиак/диоксид углерода (R-717 / R-744), для замены ГХФУ-22 в магазине розничной торговли компании Premezclas Industriales S.A., с финансированием в объеме 524 000 долл. США плюс административные расходы учреждения в сумме 36 680 долл. США для ПРООН, в соответствии с решением 72/40;
 - (c) Вычесть 0,035 тонн ОРС ГХФУ-22 из оставшегося объема потребления ГХФУ, отвечающего критериям финансирования; и
 - (d) Настоятельно рекомендовать правительству Коста-Рики и ПРООН завершить проект в течение 14 месяцев, как запланировано, и представить всеобъемлющий итоговый доклад в кратчайшие сроки после завершения проекта.

Annex I

PROJECT COVER SHEET

TYPE OF PROJECT	Demonstration project funding request
TITLE OF THE PROJECT	Demonstration of the application of R717/R744 system in replacement of the HCFC-22 for the medium sized producer and retail store of Premezclas Industriales S.A. in Costa Rica
COUNTRY NAME	Costa Rica
IMPLEMENTING AGENCY	UNDP
GOV. COUNTERPART	Ozone Unit of Costa Rica. Government of Costa Rica.

DATES OF RATIFICATION OF AMENDMENTS TO THE PROTOCOL			
London	June 1998	Copenhagen	June 1998
Montreal	May 2005	Beijing	October 2008

GENERAL INFORMATION	
Sector / Sub-sector	Refrigeration and Air Conditioning / Food Industry-Retail
ODS Consumption (sector)	8.56 ODP t.
<i>Baseline</i>	14.1 ODP t.
<i>Starting Point for Aggregate Reductions</i>	14.1 ODP t.
<i>Project Impact (ODP t.)</i>	0.0351 ODP t
Participating Company (ies)	Pre Mezclas Industriales de Panadería S.A. (PINOVA)
Eligibility of participating company (ies)	100 % (A5) 0 % (non-A5)
Project Costs (US \$)	984,595.56
MLF Requested Funding (US \$)	524,000.00
I.A. Supporting Costs (US \$)	36,680.00 (7%)
Total cost of the Project for the MLF (US \$)	560,680.00
Project Duration (months)	14

PROJECT PROPOSAL SUMMARY
<p>The proposed demonstration project will partner with the company <i>PreMezclas Industriales de Panadería S.A.</i>, taking advantage of their planning and co-finance to replace the existing HCFC-22 based refrigeration systems, by adding the incremental benefit of overlapping the use of HFCs-based system for their commercial refrigeration application through the use of the natural refrigerants system.</p> <p>The project is based on the adoption of a two stage Ammonia/CO2 system. In this setting, a reduced charge of Ammonia is expected in the primary cooling circuit (which is also to be installed as an external unit to the plant). In the other hand, liquid CO2 is to be circulated as secondary cooling, but a subcritical pressure, reducing the costs of the installation</p> <p>The project will look into the removal of barriers to the adoption of this technologies by supporting partners to assess parts and pieces, deliver specialized training and look at legal/institutional barriers for the replication of this demonstration, and also has the objective to deliver higher energy efficiency, both compared to the baseline system (HCFC-22) and to the preferred system (R-404a). This project would be highly complementary to Costa Rica's effort of becoming Carbon Neutral by 2021.</p> <p>The total cost of the project is USD 984,595.56, being that USD 524,000.00 is being requested from the Multilateral Fund, while USD 460,595.56 will be co-financed by the participatory company</p>

Project Prepared by: Rodolfo Hernandez

Technical review: Dr. Roberto Peixoto

INTRODUCTION

1. The agreement to accelerate the phase-out of the HCFCs consumption under the Decision XIX/6 also brought a growing concern to the Article 5 countries related to the establishment HCFCs replacement's policies that could also promote the use of low-GWP technologies, in order to maximize the effects over the climate change issue.

2. This is the case for the country of Costa Rica. Costa Rica had its HCFCs Phase-out Management Plan (HPMP) approved in the 64th Meeting of the Executive Committee (ExCom) for the Implementation of the Montreal Protocol. The HPMP pledged to start controlling the consumption of HCFCs with the freezing of its imports starting in 2013, with reference to the baseline reported for the period 2009-2010 (14.1). The first reduction of 10% over the baseline level will be held in 2015 and the second from 35% in 2020. The total amount approved for the implementation of the project was U.S. \$ 1,240,037 (U.S. \$ \$ 1,153,523 for project costs and U.S. \$ 86.514 for support costs).

3. On the Legal and Institutional Framework part, the country has established a complete legal framework aimed to protect the environment, counting with some norms and regulation to protect specifically the ozone layer. Since 2010, Costa Rica applies a licensing system for the import of HCFC and HFC implemented by the National Ozone Unit (NOU), Bureau of Environmental Quality Management and Energy Ministry of Environment (MINAE), in coordination with the Directorate General of Customs, Ministry of Finance and Trade Office the Ministry of Foreign Trade. In this sense, Costa Rica is in compliance with its obligations in front of the Montreal Protocol.

Table 1 - HCFC consumption as per Country Programme Report, Costa Rica

SUSTANCIA	2008	2009	2010	2011	2012	2013	2014
HCFC-124	3.20	5.94	1.95	0.00	2.31	0,84	0.91
HCFC- 22	137.28	192.81	171.77	338.62	309.53	182.16	178.26
HCFC- 141b	1.77	9.01	36.89	29.56	48.61	23.41	23.15
HCFC - 142b	1.29	0.00	7.15	0.00	9.36	2.42	2,93
HCFC – 123	0.00	0.71	0.00	0.06	0.54	2.91	2.91
SUBTOTAL	143.54	208.47	217.76	368.18	370.35	211.74	208.16
HCFC- 141b in FFS*	-	-	161.56	170.00	--	NR	11.14
TOTAL	143.54	208.47	379.32	538.18	370.35	211.74	219.3

**Fully Formulated Systems and/or Preblended Polyols*

4. On the technical side, currently, the HPMP is undertaking several field actions to support the country achieving its HCFCs staggered reductions. These interventions included the f reconversion of the Domestic Refrigeration producer with the adoption of hydrocarbons as blowing agent. In the RAC servicing sector, the NOU has been working with the National Training Institute (INA) and the aforementioned training institutions to assess their needs, improve RAC practicing laboratory and improve and deploy a better training on RAC best practices in order to prepare technicians to absorb new replacement technologies to HCFCs.

5. The HPMP had envisaged HCFCs phase-out actions both in the Polyurethane Foams (PU Foams) and the Refrigeration and Air Conditioning (RAC) sectors. Although all activities in the HPMP are

Annex I

progressing well, it is clear that the PU Foam sector has a better established technology base in terms of availability and technical knowledge available to convert HCFC-141b based industries to non-ODS and low-GWP alternatives.

6. However, this situation is still not completely clear for the interventions required do phase-out the consumption of the HCFC-22 (and other HCFC-based commercial refrigerant blend) in order to overlap HFCs and establish the basis for the adoption of final low-GWP solutions. In this sense, it has been noted that the market trend to use HFCs-based technologies as interim solutions, due to the relative low cost in comparison to flammable and toxic low-GWP alternatives. And also because of the established knowledge basis on the application and maintenance of such HFCs systems that is readily available.

7. In this sense, specific technical assistance work is being undertaken in order to expand the knowledge base of the training facilities of the country. Some specialized courses will be available from 2016 onwards in Costa Rica through INA using natural refrigerants in industrial refrigeration (Ammonia). Best practices in and air conditioning maintenance will also be promoted using a bilateral cooperation with the Colombian technical institute (SENA). In partnership with the Brazilian Training Institute (SENAI), refrigeration course curriculum is also being reviewed and upgraded truing to focus on the use of natural refrigerants (hydrocarbons for light commercial refrigeration). Also working with the public universities to introduce in the academic curriculum, the new technologies based in natural refrigerants as national strategic to increase knowledge in the new engineer professionals.

8. Despite all the efforts undertaken by the Government of Costa Rica to introduce low-GWP technologies, being mostly natural refrigerants aimed, barriers to their adoption at commercial scale still exist. It is acknowledged that drivers to technology change must be either precedent or followed for technically proven, commercially available and ready-to-use alternatives that, are not only able to be used in the HCFCs consuming sectors, but that are also suitable (or adapted) to regional/local specific requirements that, today, are barriers for their fully implementation.

9. These barriers are related to lack of technical standards, almost no availability of parts and pieces, lack of an organized trained focused on the specific application (since due to financial restrictions and due to the scope of the training institutes, training usually focus more on the generic application of refrigeration and good practices, and many times lack specific hands on training on stratified applications, such as light weight commercial refrigeration, centralized commercial refrigeration systems, self-contained commercial refrigerators and etc.).

10. This is the case for the application of Ammonia/CO₂ (R-717/R-744) systems in the food production and distribution sub-sector for mid to high ambience temperature countries. Pure Ammonia systems are, in one hand, a very well established technology for the application at large commercial/industrial scale, mainly for quick frozen applications. In the other hand, it is noticed the mixed Ammonia/CO₂ applications are being improved in northern countries – where colder temperatures, extensive training and a very well established legal basis set the grounds for a safe and efficient use of those refrigerants in a combined manner.

11. In this sense, this demonstration project proposal aims to apply an Ammonia/CO₂ refrigeration technology in a food producer and retail company located in the city of San José, Costa Rica. This innovative approach will use a two stages system where Ammonia will serve as primary refrigerant by pumping CO₂ at sub-critical pressure as the secondary coolant throughout the facility. This approach, at the first, substantially reduce the supercritical risk associated with the high working pressure of CO₂, and

Annex I

in the other hand, reduce the risk of the use of Ammonia by applying a lower charge system in an external installation limiting exposure risk of the users of the facility.

12. The proposed demonstration project will partner with the company *PreMezclas Industriales de Panadería S.A.*, taking advantage of their planning and co-finance to replace the existing HCFC-22 based refrigeration systems by adding the incremental benefit of overlap the use of HFCs-based system for commercial refrigeration through the application of the proposed natural refrigerants system and delivering higher energy efficiency, both compared to the baseline system (HCFC-22) and to the preferred system (R-404a).

13. The project will look into the removal of barriers to the adoption of this technologies by supporting partners to assess parts and pieces, deliver specialized training and look at legal/institutional barriers for the replication of this demonstration.

OBJECTIVES

14. The implementation of the proposed project in Costa Rica can demonstrate to other developing countries, mainly the ones with higher ambient temperatures, that the application of Ammonia and CO₂ technologies can be safely deployed in the field. Moreover, this system can configure a better solution to countries that have limitations to use supercritical CO₂ in direct expansion (as high ambient ones), or countries that one to overlap HFCs alternatives (since it has been noticed that developing countries tend to use cascade CO₂ systems (CO₂ sub critical), operating under subcritical conditions, but mostly using the R-404a with reduced charges as secondary fluid.

15. Therefore, the expected objectives of the project are:

- (a) To demonstrate the use of NH₃/CO₂ as an alternative to use in the refrigeration systems suitable to small to medium sized companies (applied in the assembling and maintenance sectors).
- (b) To promote the replicability of the technology by supporting the supply chain (parts, assembling companies, local cabinets and rack producers and maintainers) in absorb it and make it available to local companies.
- (c) To facilitate the transfer the technology to potentially interested companies in the future (replication).
- (d) To reduce the operative costs of the system;
- (e) To reduce energy consumption;
- (f) To significantly reduce the direct emissions of CO₂-eq gases;
- (g) To improve the training capacities of the partner to apply and maintain natural refrigerants that pose toxic risks and technical challenges in terms of working pressure;
- (h) To identify and put in place a real case example to enable the country to remove barriers to the adoption of toxic, flammable and high pressure systems with a natural refrigerants;
- (i) To Phase-out the consumption of 909kg of HCFC-22 of the partner company of the project.

EXPECTED RESULTS

16. The expected results of the project are:
- (a) First food producer and retailer in the Central American and the Caribbean Region reconverted and applied a two stage NH₃/CO₂ system;
 - (b) Economic, Financial and technical feasibility demonstrated for the NH₃/CO₂ project conversion in comparison to standard single Ammonia direct expansion system;
 - (c) CO₂ equivalent impact reduced through the elimination of source of direct emissions.
 - (d) Technology and technical scenario in Costa Rica improved through the Project interventions.
 - (e) Technical standards for the application of NH₃/CO₂ drafted;
 - (f) Identify energy consumption (if any) reduction that may be achieved by the end of the Project.

SECTOR BACKGROUND

17. With the exception of the local manufacturing of domestic refrigerators, Costa Rica does not have production of refrigeration and air conditioning equipment. All HCFCs consumption is directed to the assembling and servicing sectors in the country.

18. As a “technology taker”, Costa Rica depends on imports of finalized equipment or its parts so, specifically, commercial refrigeration systems are assembled in the country to meet the market demands (for central equipment). For the self-contained applications of commercial refrigeration (freezers, displays, vending machines, etc.) and for the air conditioning subsector, all equipment is imported and, for this reason, the country is also highly dependent on the technology available at the production source.

19. Currently, it is still identified a demand for HCFC-based equipment which is basically constrained by the obligations under the Montreal Protocol and the work undertaken by the Government through its HPMP. As interim solution, the most common alternative being used in the country are HFC-based ones (for example: R-410A for air conditioners, R-404a for commercial refrigerators). This fact is due to the relative low cost of such technologies in front of other that use natural refrigerants; the lack of standards that would enable the conditions for transportation, sales and use; and the lack of specific training for each of the recipient application.

20. However, it is recognized that the country has certain familiarity with direct Ammonia application in the large industrial sector. However, this is a very unique issue, since these applications are guided by international standards; usually are multinational companies applying those; the Ammonia is constrained at external equipment and the plants are installed in proper industrial zones were the exposure risks become minimal; and there is relative small number of very specialized RAC assembling and servicing companies that received international training to oversight, operate and maintain such equipment.

21. On the other hand, it is difficult to absorb other alternatives, such as CO₂ and Hydrocarbons in the RAC sector, precisely because the country lacks the features highlighted above. On top of that, the phase-in costs are higher in the country because all equipment must be imported.

22. It is under this scenario that this demonstration project is being proposed: a partnership with the company *PreMezclas Industriales de Panadería S.A.*, taking advantage of their planning and co-finance to replace the existing HCFC-22 based refrigeration systems by adding the incremental benefit to overlap the use of HFCs-based system for commercial refrigeration through the application of the NH₃/CO₂ “brine” system in order to reduce CO₂-equivalent direct emissions and achieve higher energy efficiency

23. The technology choice was based on the fact that this would be the first two stage NH₃/CO₂ “brine” refrigeration technology in a food producer and retail company located in the Central American and Caribbean regions. This innovative approach will use a two stages system where Ammonia will serve as primary refrigerant by pumping CO₂ as the secondary coolant throughout the facility. This approach, at the first, substantially reduce the supercritical risk associated with the high working pressure of CO₂, and in the other hand, reduce the risk of the use of Ammonia by applying a lower charge system in an external installation limiting exposure risk of the users of the facility The energy efficiency and cost comparison will be made against the baseline system (HCFC-22) and to the initially preferred system (R-404a).

INSTITUTIONAL ARRANGEMENTS

I. Legal and Regulatory Framework

24. The country Costa Rica has currently regulations that are specifically for HCFCs import/export controlling, as well as a fully functional import quota system in place since 2013. The Government is able regulate importation, trade and usage of any ODS that is controlled under the Montreal Protocol. Unregistered companies are not allowed to import, export, market and/or use ODS. It is prohibited to use CFCs substances in new systems, equipment and products, national and imported, and under the HPMP, supported with the results of this demo, a stringent sector approach to prohibit use and ban consumption of HCFCs may be put into practice to support the country to meet the Montreal Protocol obligations.

25. Imports and exports of all ODS are subject to registration at customs and can be made subject to quota's when need arises. An issue, however, is ODS contained in systems and equipment, as custom registration does not identify these.

II. Institutional Structure

26. The Ministry of Environment and Energy has the mission of promote the adoption of principles and strategies to the knowledge, protection and recovery of natural resources; the improvement of the value of the environmental services; and insertion of sustainability development on the formulation and implementation of public policies, in participative and democratic manner. The Ministry of Environment and Energy also acts as National Ozone Unit for the MP and coordinates the formulation and implementation of all projects funded by the MLF.

27. Under this proposed project, UNDP will serve as implementation agency (IA) working in close coordination with the Ministry of Environment and Energy, through the National Ozone Unit (NOU), which will act as executing agency for the project implementation.

III. Implementation Approach

28. The implementation modality to be used in this specific project preparation proposal will be through NIM (National Implementation Modality).

29. Under this implementation modality UNDP will be responsible for:

- Deliver technical and administrative support to the NOU;
- Undertake the oversight and monitor the implementation;
- Facilitate payments and undertake audits;
- Prepare contracts and other legal documents required for the implementation of the activities;
- Support the Government in procurement processes, hire international and local experts and service providers required to assure the good implementation of the Project;
- Participate in the Project Steering Committee;
- Assure that the Montreal Protocol's and the ExCom's guidelines and Decisions are effectively implemented;
- Deliver training to the implementation training when required; and
- Recollect project information, organize findings and report back to the MLF.

30. The National Ozone Unit will be implementation partner of the project being responsible for:

- Formulation of specific legislation and guidelines required for the project implementation;
- Draft, in close coordination with relevant institutions and stakeholders, guidelines and standards required for the project implementation; and support their approval process;
- Undertake the implementation of the projects activities in the field, with assistance from UNDP;
- Collect and organize information generated by the project;
- Coordinate activities with the stakeholders, undertake awareness necessary for the Project implementation;

31. The NOU is housed by the Ministry of Environment (MINAE) and is the focal point for all matters related to the Montreal Protocol in the country.

IV. Government Commitment's to the Project

32. The Government of Costa Rica is fully committed to the proposed demonstration project. The Annex I of this document brings the Transmittal Letter of the Government of Costa Rica confirming its full commitment to the project, informing the forecast for its completion that not exceeds 14 months.

PARTICIPATING COMPANY

33. This pilot project is designed around the recipient company Pre Mezclas Industriales para Panadería S.A. Contact information is as follows:

Annex I

Company:	Pre Mezclas Industriales para Panadería S.A
Contact:	Adrian Bonilla Astua
Address	San Jose, Uruca
Phone:	2437-7700
E-mail:	adrian.bonilla@musmanni.com
Website (if any):	www.musmanni.com
Foundation date:	1980
Capital:	100% Costa Rica
HCFC installed capacity (kg) in all units(including service demand per year)	2011: not available 2012: 680.56 2013: 387.23 2014: 461.14 2015: 1,353.10

34. The Annex II of this project preparation funding request brings the Letter of Commitment of the company, confirming its full commitment to the project, informing the forecast for its completion expected to be within 12 (twelve) months.

35.

PROJECT DESCRIPTION

36. The company *Pre Mezclas Industriales de Panaderia S.A.* currently operates with three pre-chambers and one chamber for final products with 50 tonnes of refrigeration (TR) capacity and storage capacity of 150 metric tonnes (MT). As of today, the systems runs with a 15 years old HCFC-22 central unit composed by by two scroll compressors (60 hp each) and 14 heat exchangers. Currently, the system has 909kg of refrigerant charged, being that in 2015 this same unit has demanded 639kg (0.0351 ODP t) of HCFC-22 for recharge due the maintenance requirements (consumption). The system has an energy demand of 136,031 kwh/month, responding for 18% of the total energy consumption of the facility.

37. This proposed project will allow the company to reduce to zero its HCFC demand, allowing the company to achieve another step required for the public plan of carbon neutrality signed with the Government and support Costa Rica also de reduce its HCFC consumption.

38. The project is based on the adoption of a two stage NH₃/CO₂ system. In this setting, a reduced charge of Ammonia is expected in the primary cooling circuit (which is also to be installed as an external unit to the plant). In the other hand, liquid CO₂ is to be circulated as secondary cooling, but a subcritical pressure, reducing the costs of the installation (when compared to other supercritical/subcritical CO₂ systems) and also almost eliminating the associated risk with pressure.

39. It is important to highlight that Costa Rica has some experience with the use of direct expansion systems charged with ammonia in the very large scale industrial sector. However, this affirmation cannot be applied to the use of CO₂, since no facility in the country operates this technology. Moreover, capacities to install, operate and maintain a dual NH₃/CO₂ system will need to be built under the proposed demonstration project.

40. The technology proposed was chosen after a thorough review of the needs of the company, the country's set and the beneficial replication/scale up benefits sought at the regional and global level. It is

Annex I

anticipated that the technology could be easily replicate to Article 5 countries, mainly those ones with high ambient temperatures.

41. In this sense, the following technical parameters of the recipient`s plant had to be carefully weighted:

Table 3 . Technical Requirements of PreMezclas Plant:

Feature	Requirement
Chambers temperature:	-20° Celsius
Chambers Humidity	70%
Maximim Storage Capacity	250 MT
Intake product frozen temperatura	-16° Celsius
Outake product frozen temperatura	-11° Celsius
Avarage Residence time of the product in the chamber	7 days
Electrict Voltage	480 v

42. In this sense, the two stage NH₃/CO₂ system is expected to be mounted as the following diagram:

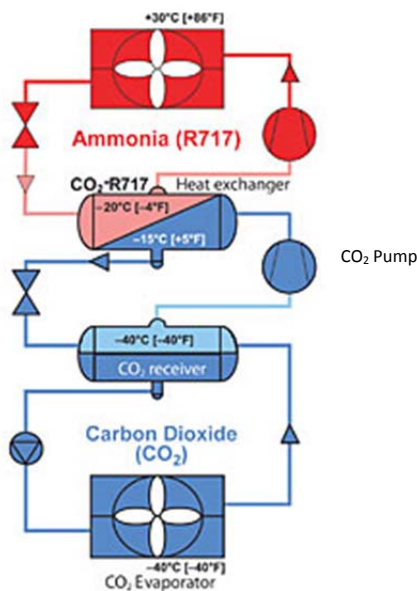

Diagram 1 – simplified working scheme

Source: <http://www.process-cooling.com/>

43. The proposed system is commercially known as “brine”, suitable for applications at temperatures ranging from -5oC to -40oC (being able to meet requirements from commercial refrigeration and industrial chambers). The system uses direct expansion of Ammonia in the primary system, a heat exchanger that will allow the exchange of heat between Ammonia and CO₂, and a pumping system to circulate liquid CO₂ in low pressure throughout the facilities (so there is no exposure risk inside the facility and to the foods). The main components required to assemble this system are:

- Primary cooling system for Ammonia

Annex I

- Heat exchanger for the secondary unit (NH₃/ CO₂)
- Liquid CO₂ pumping station
- CO₂ Evaporator.
- CO₂ and NH₃ condenser.

44. The proposed system has the following benefits:

- Ammonia is used in the primary unit (high pressure) to condensate the CO₂;
- Lower charge of Ammonia in the system;
- There is no charge of Ammonia in the evaporators (lower venting risks);
- There is no contamination risk over the final product;
- The CO₂ is condensate without compression (no pressure risk), no compressor for CO₂;
- No lubricant oil in the secondary cooling system;
- No high pressure resistant (and therefore, lower cost) tubing in the secondary system;
- Smaller diameters of tubes in the secondary system;
- Full compatibility between materials;
- Latent heat of CO₂ is better used (approx. 30X more efficient than other secondary coolants);
- Lower energy consumptions (anticipated to be 20-30% less than the baseline system).

45. On the other hand, some disadvantages must be taken into consideration when designing the system:

- High pressure of overall design;
- Higher initial investment cost (when compared to HCFC or HFC systems).
- Higher pressure if the system is shut down.

Pre-chambers evaporators scheme (1 per pre-chamber)

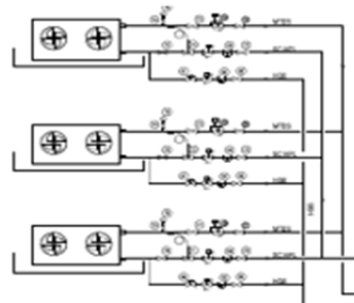

Annex I

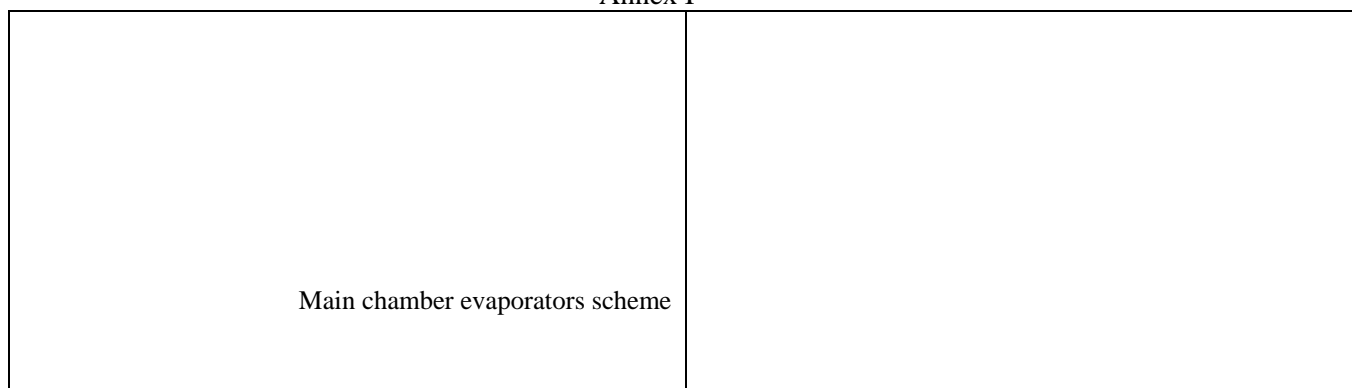

Diagram 2 – detailed working scheme of evaporators

46. Due to the efficiency of the new proposed system, the new thermal load was calculated in 75.8TR, against 150 TR of the HCFC-22 current in operation. The specific list of equipment and parts required for the project implementation are the following:

Table 4 - List of Equipment (and cost breakdown - USD)

Quantity	Description	Cost Unitary \$USD	Total Cost \$USD
3	CO2 Evaporators. 17.6 TR each	19,068.00	57,204.00
1	CO2.Evaporators 8.2 TR each	12,207.00	12,207.00
3	CO2.Evaporators 6.5 TR each	4,678.00	14,034.00
1	Liquid CO2 Tank/Reservoir	15,572.00	15,572.00
2	Liquid CO2 centrifugal pumps	9,702.00	19,404.00
1	Heat Exchanger (NH3 to CO2).	36,953.00	36,953.00
1	CO2 Valves and Controls kit.	47,494.00	47,494.00
1	Liquid/Gas separator for NH3.	9,138.00	9,138.00
1	Oil separator tank.	2,023.00	2,023.00
2	Scroll compressor for NH3 38.9 TR each. (including parts)	81,970.00	163,940.00
1	Evaporative condenser for NH3 (including parts)	54,685.00	54,685.00
1	Thermo tank to compressor oil cooling.	4,267.00	4,267.00
1	Reservoir for liquid NH3.	6,312.00	6,312.00
1	NH3 Valves and Controls kit.	43,018.00	43,018.00
1	Control panel. (Power, Control and PLC)	83,856.00	83,856.00
1	PU foam insulating kit for the tubing.	9,138.00	9,138.00
Total equipment			579,245.00

Table 4.1 - Detailed List of Evaporators

Chamber	Quantity of evaporators	Unit Capacity (TR)	Capacity total (TR)
Chamber 4, final product	3	17.6	61
	1	8.2	
Chambers 1, 2 and 3 (unfinished products, charging and maneuvering areas)	3	6.5	19.5

47. It is important to highlight that the adoption of this technology demands tighter controls, monitoring and maintenance practices for both refrigerants. Capacity needs to be built on such pre-

Annex I

requisites to assure proper handling and avoid accidents. It is correct that the design of the installation is made to reduce leakage risks. However, even with risks reduced and smaller charges, Ammonia is a toxic substance, and Costa Rica will endeavor efforts to adopt proper technical guidelines and standards to enable the conditions to the safe applications and further replication of the project (specifically, but not limited to, the ASHRAE Standard 34).

48. This knowledge is expected to be built within all level of the supply chain (including the support to make parts and knowledge on use available), training institutions and engineering universities in the country. (Removal of barriers component).

PROJECT BUDGET

49. The table 5, below, informs the budget breakdown by investment component of the project.

Table 5 – Investment Component Project Budget

Item	USD
Equipment	579,245.00
Demurrage and delivery of imported equip.	17,529.65
Physical Structure adaptation (civil Works)	43,206.20
Assembling, Installation and Comissioning	191,348.51
Registration and Homologation of Engineering Plans	13,266.20
Contingencies	60,000.00
Total Equipment	904,595.56

50. Additionally, as highlight in the project`s objectives, the demonstration proposal will also look in to the removal of barriers needed to apply the technology and secure its further replication. In this sense, the additional technical assistance costs are estimated:

Table 6 – Technical Assistance Project Budget

Item	USD
International Expert	30,000.00
National Expert	25,000.00
Capacity Building (Pilot Training)	25,000.00
Total TA	80,000.00

51. Finally, the project budget can be summarized as follows:

Table 7 – Summary Project Budget

Component	Item	MLF Funding	Co-funding	TOTAL
		USD	USD	USD
Component 1. Equipment & Reconversion Process	Equipment	344,000.00	234,245.00	579,245.00
	Demurrage and delivery of imported equip.	-	17,529.65	17,529.65
	Physical Structure adaptation (civil Works)	-	43,206.20	43,206.20
	Assembling, Installation and Comissioning	100,000.00	91,348.51	191,348.51
	Registry and Homologation of Engineering Plans	-	13,266.20	13,266.20
	Contingencies	-	60,000.00	60,000.00
Subtotal Equipment		444,000.00	460,595.56	904,595.56
Component 2. Technical Assistance	International Expert	30,000.00	-	30,000.00
	National Expert	25,000.00	-	25,000.00
	Regulatory and Standard Framework	7,500.00	-	7,500.00
	Capacity Building (Pilot Training)	25,000.00	-	25,000.00
	Completion workshop	10,000.00	-	10,000.00
	Contingencies	10,500.00	-	10,500.00
Subtotal Technical Assistance		80,000.00	-	80,000.00
GRAND TOTAL		524,000.00	460,595.56	984,595.56

IMPLEMENTATION PLAN/TIMESCALE

	Month													
	1	2	3	4	5	6	7	8	9	10	11	12	13	14
Administrative Support and Oversight														
Project Approval	■													
Receipt of Funds		■												
Project Document			■											
Consultants Hired			■	■										
Monitoring			■			■			■			■		
Operational Closure													■	
Financial Closure														■
PCR (up to 6 months later closure)														■
Component 1														
Approval of Engineering Plans	■	■												
Design of Technical Specifications		■	■											
Procurement of Equipment			■	■	■	■	■	■	■	■				
Adaptation/Civil Works				■	■	■	■	■	■	■				
Installation/Commissioning										■	■	■	■	
Start up												■	■	
Energy Consumption Measures													■	
Component 2														
Review of Standards			■	■										
Draft of Standards			■	■	■	■	■	■	■					
Consultation Meetings			■						■					
Training										■	■	■	■	
Project Report													■	■
Closure Workshop	-	-	-	-	-	-	-	-	-	-	-	-	-	-

FINAL REPORT

52. All the activities undertaken at and by the Company Premezclas will be monitored and registered under the Project. This information will be analyzed and systematized in order to form part of the Final Report on the project implementation to be submitted to the MLF.

53. It is anticipated that the project will undertake and register the working conditions of the current HCFC-22 based system, undertake energy consumption measures and register all information deemed necessary.

54. The project implementation will be assisted and evaluated by the International Expert in charge of it. He/she will deliver high level technical guidance during the conversion process and will lead the process of collect data and report to both UNDP and the MINAET.

55. Information about cost, barriers, challenges and lessons learned will be gathered and will compose the Final Report, as well as an analysis of the cost-benefit of the process and energy savings generated by the new system

Annex I

56. Finally, the report is expected to be submitted to the second meeting of the ExCom of 2017, followed by a regional workshop to be held in Costa Rica that will serve to disseminate the project results, findings, recommendations and lessons learnt to interested parties. The Report is also expected to be shared with other National Ozone Units and private sector.

RISK ASSESSMENT

Risk	Degree	Action
Cost of technology	High	Project will provide co-funding to minimize this risk and serve as driver of change towards low-GWP technology.
Lack of Information on the technology	Medium	Promote close collaboration between GOV and private sector (international suppliers and national stakeholders) in order to allow wide access to information and data on the technology.
Lack of skilled people in the country	High	Create and establish a training programme suited to the application of proposed technology and promote cooperation with national technical institutes and universities to replicate the training contents and incorporate those in their curricula.
Lack of local parts and services providers	High	Involve national stakeholders in the technology assessment and dissemination process. Assure the continuous flow of information. Facilitate contacts between national and international suppliers. Review institutional and regulatory barriers to import procedures (and barriers) and deploy training to “popularize” the technology.
Lack of trust in the application of technology	Medium	Create/adopt technical standards. Overcome barriers and paradigms that may block the technology update. Undertake awareness campaign to promote the technology.

Annex I

ANNEX I

GOVERNMENT TRANSMITTAL LETTER



Transmittal Letter
GOV CR.pdf

ANNEX II

PARTICIPATING COMPANY LETTER OF CONFIRMATION



Letter of
Confirmation PINOV