



**Programme des
Nations Unies pour
l'environnement**



Distr.
GÉNÉRALE

UNEP/OzL.Pro/ExCom/73/17/Add.1
21 octobre 2014

FRANÇAIS
ORIGINAL: ANGLAIS

COMITÉ EXÉCUTIF
DU FONDS MULTILATÉRAL AUX FINS
D'APPLICATION DU PROTOCOLE DE MONTRÉAL
Soixante-treizième réunion
Paris, 9-13 novembre 2014

Addendum

RAPPORTS DE SITUATION ET DE CONFORMITÉ

Le présent document est publié pour **ajouter** un article sur les projets ayant des exigences spécifiques en matière de rapports.

1. Le présent article aborde les projets et les activités pour lesquels des rapports spécifiques ont été demandés lors des réunions précédentes et qui nécessitent l'attention du Comité exécutif. Ces rapports comportent les parties suivantes:

- Partie IV: Projets de démonstration sur les HCFC
- Partie V: Rapports de vérification financière pour le halon, la production de CFC, la mousse, les agents de transformation II, les solvants et les secteurs de l'entretien de la réfrigération à base de CFC en Chine
- Partie VI: Les plans nationaux d'élimination du CFC
- Partie VII: Le projet d'élimination du bromure de méthyle (BrM) au Guatemala
- Partie VIII: L'élimination et la gestion des déchets PAO
- Partie IX: La mobilisation des ressources

2. Chaque partie contient une brève description des progrès, ainsi que les observations et les recommandations du Secrétariat.

PARTIE IV: LES PROJETS DE DÉMONSTRATION SUR LES HCFC

Mondial: Le projet de démonstration sur la conversion de la technologie à base de HCFC-22/HCFC-142b en une technologie à base d'agent de soufflage au formiate de méthyle et au CO₂ dans la fabrication de mousse en polystyrène extrudée (XPS) chez Feininger (Nanjing) Energy Saving Technology Co. Ltd.

Contexte

3. Lors de sa 64^e réunion, le Comité exécutif a approuvé le projet de démonstration sur la conversion de la technologie à base de HCFC-22/HCFC-142b en une technologie à base d'agent de soufflage au formiate de méthyle et au CO₂ dans la fabrication de mousse en polystyrène extrudée (XPS) chez Feininger (Nanjing) Energy Saving Technology Co. Ltd., mis en oeuvre par le PNUD (décision 64/47). L'objectif du projet était d'établir la pertinence du CO₂ avec une technologie de soufflage au formiate de méthyle comme une solution de remplacement viable de l'agent de soufflage aux HCFC-22/HCFC-142b utilisé actuellement dans la fabrication de mousse XPS.

4. Lors de la 73^e réunion, le PNUD a présenté le rapport final sur le projet de démonstration. Le rapport technique complet figure à l'annexe I du présent document.

Sommaire exécutif

5. Les activités suivantes ont été réalisées: l'évaluation du plan de modernisation; l'acquisition, l'installation et la mise en service de l'équipement; l'exécution d'un projet pilote; l'essai des propriétés; l'évaluation de faisabilité industrielle; et la formation sur le processus et les questions de sécurité.

6. Afin de produire de la mousse XPS avec du CO₂ et du formiate de méthyle, Feininger a actualisé sa chaîne de production originale et modernisé ses systèmes de ventilation et de sécurité incendie de l'usine de production. Les systèmes de soufflage comprenant du CO₂ et du formiate de méthyle, et du CO₂/formiate de méthyle/éthanol ont été évalués. Le PNUD a conclu que la formulation de CO₂ et de formiate de méthyle testée peut être appliquée à la fabrication de mousse XPS étant donné que la conductivité thermique, la résistance à la compression et l'indice critique d'oxygène sont acceptables. Il a aussi été déterminé que l'utilisation du formiate de méthyle comme agent de soufflage du CO₂ n'avait pas d'influence significative sur le processus de traitement de panneaux XPS.

7. La chaîne de production est lancée commercialement et les surcoûts d'exploitation seront distribués à l'entreprise en 2015. La faisabilité de l'application industrielle du formiate de méthyle avec le CO₂ et l'éthanol dans la production de panneaux en mousse XPS a été vérifiée.

8. Les surcoûts d'exploitation actuels de la conversion étaient de 1 743 186 \$US, dont 1 557 635 \$US ont été fournis par le Fonds multilatéral et 185 551 \$US ont été cofinancés par l'entreprise. Les surcoûts d'exploitation annuels ont été estimés à 531 200 \$US par le PNUD (tableau 1). Bien que la ligne de production soit lancée commercialement, les surcoûts d'exploitation sont toujours des valeurs préliminaires.

Tableau 1: Surcoûts d'exploitation estimés pour la technologie au CO₂ et au formiate de méthyle dans la fabrication de mousse XPS

Source du surcoût d'exploitation (*)	Technologie à base de HCFC		Technologie à base de CO ₂	
	Consommation par année (kg)	Coût (\$US)	Consommation par année (kg)	Coût (\$US)
HCFC-22/142b	200 000	380 000	-	
CO ₂	-		120 000	13 200
Formiate de méthyle	-		80 000	180 000
Matières premières	2 000 000	2 900 000	2 000 000	(**) 3 600 000
Total		3 280 000		3 793 200

(*) HCFC-22/142b: 1,9 \$US/kg; matières premières (matériaux récupérés): 1,45 \$US/kg; CO₂: 0,11 \$US/kg; formiate de méthyle: 2,25 \$US/kg; matières premières (nouveaux matériaux en résine de polystyrène): 1,8 \$US/kg.

(**) La formulation de HCFC utilisait des matériaux recyclés, et la formulation de formiate de méthyle et de CO₂ utilisait de nouveaux matériaux en résine de polystyrène dans la démonstration.

Remarque: le calcul du surcoût d'exploitation ne comprend pas le coût de l'agent ignifuge supplémentaire nécessaire pour le fonctionnement au CO₂ et au formiate de méthyle. On estime que l'utilisation de cet agent augmenterait le prix du produit d'environ 20 pour cent.

9. Le projet de démonstration a entraîné une réduction de la consommation de HCFC de 12,3 tonnes PAO et une réduction des émissions annuelles de 420 250 tonnes équivalant au CO₂; la démonstration et la disponibilité d'une méthode de remplacement respectueuse de l'environnement, rentable et reproductible pour les entreprises du secteur de la mousse XPS en Chine et dans les autres pays concernés par l'article 5; l'utilisation de ce produit dans différentes applications; et l'adoption de normes de sécurité sur la fabrication de panneaux XPS.

Commentaires du Secrétariat

10. En notant que le calcul du surcoût d'exploitation a été effectué en fonction de l'utilisation de nouveaux matériaux en résine de polystyrène plutôt que de matériaux récupérés, le Secrétariat a demandé si la technologie testée pouvait utiliser des matières premières récupérées, comme il est requis par de nombreuses entreprises en Chine. Le PNUD a expliqué que bien que l'évaluation était fondée sur des matériaux neufs, des matériaux en polystyrène récupérés pourraient également être utilisés. Cependant, la performance de la mousse ne serait pas aussi bonne que si elle était produite avec des matières premières neuves. Actuellement, la chaîne de production de Feininger utilise le matériau en polystyrène récupéré. En se fondant sur ces informations, le Secrétariat note que dans le cas de Feninger, l'utilisation de matériaux récupérés coûterait 2 900 000 \$US au lieu de 3 600 000 \$US (comme l'indique le tableau 1), ce qui permet de réaliser des économies d'exploitation de 186 800 \$US.

11. En fournissant des précisions supplémentaires sur les caractéristiques et les coûts de l'agent ignifuge nécessaire pour la technologie, le PNUD a expliqué que l'hexabromocyclododecane (HBCD) était l'agent ignifuge utilisé. Les panneaux XPS produits avec la formulation de CO₂/formiate de méthyle/éthanol ont besoin de cinq fois plus d'agents ignifuges que ceux produits avec la technologie à base de HCFC, ce qui accroît le coût du produit d'environ 20 pour cent. Ce coût s'ajoute aux surcoûts d'exploitation calculés dans le tableau 1 qui ne tenait compte que de l'agent de soufflage.

12. En fournissant plus de détails sur les exigences principales et les difficultés dans l'adoption de cette technologie par les autres entreprises dans les pays concernés par l'article 5, le PNUD a expliqué les points suivants:

- (a) En Chine, la technologie pourrait être utilisée pour les applications de mousse XPS où les exigences de sécurité ne sont pas aussi strictes (p. ex. l'isolation contre le gel des routes, des voies ferrées, des zones de circulation et d'autres applications de génie civil). Dans d'autres pays concernés par l'article 5, les utilisations dépendraient des exigences en matière de sécurité pour les matériaux de construction;

- (b) La technologie pourrait être utilisée dans les hautes latitudes. Dans les pays de basses latitudes, la technologie pourrait être appliquée en utilisant des réservoirs sous pression pour le transport et le stockage en raison du point d'ébullition bas du formiate de méthyle (32 °C). Comme ces éléments supplémentaires augmentent les coûts, de nombreuses entreprises de mousse XPS soutenues par le plan de gestion d'élimination du HCFC (PGEH) en Chine, y compris le deuxième secteur de Feininger, ont préféré passer au CO₂ et à l'éthanol plutôt qu'au CO₂ et au formiate de méthyle. Les autres raisons de choisir l'éthanol au lieu du formiate de méthyle sont l'accessibilité et le fait que la matière auxiliaire pour la technologie est bien étudiée et perfectionnée dans le pays; et
- (c) À l'heure actuelle, les coûts d'équipement et de transformation sécuritaire pour la technologie au CO₂ et au formiate de méthyle sont plus élevés que les coûts de la technologie à base de HCFC. À mesure que la technologie se perfectionnera, il sera possible de l'utiliser dans les petites ou moyennes entreprises (PME) si les coûts diminuent.

13. Après avoir abordé tous les commentaires soulevés par le Secrétariat, le PNUD a révisé le rapport final du projet de démonstration en conséquence.

Recommandations du Secrétariat

14. Le Comité exécutif peut souhaiter envisager les points suivants:

- (a) Prendre note du rapport final du projet de démonstration sur la conversion de la technologie à base de HCFC-22/HCFC-142b en une technologie à base d'agent de soufflage au formiate de méthyle et au CO₂ dans la fabrication de mousse en polystyrène extrudée (XPS) chez Feininger (Nanjing) Energy Saving Technology Co. Ltd. en Chine, présenté par le PNUD et contenu dans le document UNEP/OzL.Pro/ExCom/73/17/Add.1; et
- (b) Demander aux agences bilatérales et d'exécution de tenir compte du rapport du PNUD sur la technologie à base d'agent de soufflage au formiate de méthyle et au CO₂ dans la fabrication de mousse XPS, ainsi que des informations sur d'autres solutions de remplacement, lors du soutien apporté aux pays concernés par l'article 5 dans la préparation de projets pour l'élimination des HCFC dans les applications de mousse XPS.

Chine: Rapport final sur le projet de démonstration pour la conversion du HCFC-22 en propane chez Midea Room Air Conditioner Manufacturer Company et Guangdong Meizhi Co.

Contexte

15. L'ONUDI a présenté à la 73^e réunion le rapport final sur les projets de démonstration pour la conversion du HCFC-22 en propane (HC-290) dans la fabrication de climatiseurs individuels et de compresseurs chez Midea Room Air Conditioner Manufacturer Company (Midea) et Guangdong Meizhi Co. respectivement. Les projets de démonstration visaient à valider l'utilisation du HC-290 comme un réfrigérant dans la fabrication de climatiseurs individuels et de compresseurs. Le rapport complet figure à l'annexe II du présent document.

Conversion de la chaîne de production de climatiseurs chez Midea*Rapport d'étape*

16. La conversion de la chaîne de production chez Midea est achevée. L'inspection de sécurité du produit a été réalisée et l'acceptation nationale a été accordée. L'autorité de certification de la Chine a certifié la conformité des climatiseurs à base de HC-290 à la norme nationale GB4706.32, qui permet l'utilisation de réfrigérants inflammables dans les produits de climatisation sur le marché local. Les climatiseurs à base de GC-290 ont également reçu des certificats émanant d'organismes de certification internationaux.

Applicabilité technique et performance du produit

17. Deux types d'unités à base de HC-290 (unité à fréquence variable et unité portable) et six modèles ont été développés et sont disponibles pour la production de masse. Le rapport a conclu que le HC-290 est considéré comme la solution de remplacement idéale au HCFC-22 dans le secteur de la fabrication de climatiseurs. La performance des climatiseurs à base de HC-290 répond aux exigences des normes nationales et internationales. La performance des modèles portatifs est de 15 pour cent à 19 pour cent plus élevée que les unités R-410A, et la performance des modèles à éléments séparés est comparable à celle des unités HFC-410A. Selon les essais menés par Midea, l'efficacité énergétique des climatiseurs à base de HC-290 est de 5 pour cent à 12 pour cent plus élevée que celle des unités à base de HCFC-22.

18. En raison de l'inflammabilité du HC-290, la charge de réfrigérant a été réduite. Des caractéristiques de sécurité, y compris la détection des fuites et le confinement, ont été ajoutées au produit pour éviter que les fuites de réfrigérant n'atteignent la limite explosive. Des mesures de sécurité supplémentaires doivent être perfectionnées dans le stockage, le transport, l'installation et la mise en service des appareils chez les clients pour permettre la pleine commercialisation du produit.

Surcoûts

19. Les surcoûts en capital pour la fabrication de climatiseurs ont été présentés à la 71^e réunion et demeurent inchangés dans le rapport final. Les surcoûts en capital provenaient principalement des composantes suivantes: équipement de traitement pour l'échangeur thermique (62,08 pour cent); équipement pour la conversion de la chaîne de montage, y compris le stockage et l'approvisionnement de HC-290, la détection et les tests de fuites, l'aspirateur, la ventilation et autres mesures de sécurité pour la zone de travail (29,74 pour cent); et l'équipement d'essai de la performance d'exploitation (8,18 pour cent).

20. Les surcoûts d'exploitation sont de 41,95 \$ par unité pour la fabrication d'unités à éléments séparés à base de HC-290. Les principales augmentations proviennent des détecteurs de fuites électroniques (16,33 \$US) et de l'installation (21,31 \$US) en raison des exigences de sécurité. Le rapport indique que la hausse des surcoûts d'exploitation est associée à l'initiation du produit et que ces coûts devraient diminuer à l'avenir.

Conversion de la chaîne de production de compresseurs chez Guangdong Meizhi Co.*Rapport d'étape*

21. La conversion de la gamme de produits a été achevée en juin 2013. Tous les équipements et toutes les installations de laboratoire ont été installés et testés. Une production d'essai a été réalisée. Deux types (à fréquence fixe et variable) et trois modèles de compresseurs ont été conçus. Un prototype a été testé et a répondu à toutes les exigences de la norme nationale chinoise. La commission finale de la chaîne de production convertie est prévue pour novembre 2014.

Applicabilité technique et performance du produit

22. La performance du compresseur à base de HC-290 est conforme aux normes nationales et internationales, et a été certifiée par des autorités compétentes. Selon les essais menés par Guangdong Meizhi Co., l'efficacité énergétique des compresseurs à base de HC-290 est de 2 pour cent à 5 pour cent plus élevée que celle des compresseurs à base de HCFC-22.

Surcoûts

23. Les surcoûts en capital pour la fabrication de compresseurs ont été présentés à la 71^e réunion et mis à jour avec une légère augmentation (694 \$US) dans le rapport final. Les surcoûts en capital provenaient principalement du coût de l'équipement pour la conversion de la chaîne de montage (89,46 pour cent), du soutien technique, y compris la conception, la consultation d'experts et les essais (8,39 pour cent), ainsi que des essais de production et de la formation du personnel (2,15 pour cent). Les surcoûts d'exploitation présentés à cette réunion dans le rapport final sont de 7,57 \$US par unité. Les surcoûts d'exploitation n'ont pas été financés.

Commentaires du Secrétariat

24. Les projets de démonstration pour la fabrication de climatiseurs ont été essentiels au développement d'unités à base de HC-290 et à l'utilisation de la technologie dans le secteur de la climatisation en Chine. Ces projets ont servi de base pour la stratégie d'élimination du plan d'élimination dans le secteur de la climatisation en Chine. Selon les résultats du projet de démonstration, de nombreux fabricants de climatiseurs ont commencé la recherche, le développement, ainsi que des activités de conversion en utilisant la technologie à base de HC-290. Comme il est indiqué dans le rapport d'étape pour la troisième tranche du secteur de la climatisation¹, 13 chaînes de production pour la fabrication de climatiseurs et trois chaînes de production pour la fabrication de compresseurs passeront à la technologie à base de HC-290. Davantage de recherche et de développement sur l'application du HC-290 sont en cours dans le contexte de la mise en oeuvre du PGEH. Avec le soutien des activités d'assistance technique, il est prévu qu'un nombre croissant de fabricants dans le secteur de la climatisation choisiront le HC-290 comme technologie de remplacement pour contribuer à l'élimination des HCFC.

25. Le Secrétariat a noté qu'une vaste optimisation a été entreprise pendant la conversion et a demandé dans quelle mesure cela a contribué à l'amélioration de l'efficacité. L'ONUDI a indiqué que l'optimisation du système était souvent nécessaire pour les conversions de fabrication d'équipements de réfrigération. Pour ce qui est du projet de démonstration, l'amélioration de l'efficacité résulte principalement de l'optimisation du système, grâce à la recherche et au développement, par Midea et Guangdong Meizhi Co. dans les dernières années. Ces optimisations étaient nécessaires pour compenser les effets des restrictions de charge des réfrigérants sur la performance énergétique des climatiseurs à base de HC-290 afin de pouvoir répondre aux normes. Le simple changement du réfrigérant HCFC-22 au réfrigérant HC-290 aurait pu aboutir à une performance moindre des nouvelles unités par rapport à l'unité à base de HCFC-22. Une plus grande amélioration de l'efficacité pourrait être atteinte si les restrictions de charge prescrites par les normes internationales étaient assouplies.

Conversion de la chaîne de production de climatiseurs chez Midea

26. Bien que les surcoûts d'exploitation calculés soient élevés (41,95 \$US par unité), le Secrétariat a noté que l'économie d'énergie n'est pas prise en compte dans le calcul. L'ONUDI a fait valoir que le gain d'efficacité énergétique n'est pas lié directement aux surcoûts d'exploitation. L'économie est à l'avantage des utilisateurs finaux. Les clients pourraient préférer un produit plus écoénergétique, même si le prix

¹ Le rapport d'étape sur la phase I du PGEH pour le secteur de la climatisation en Chine est contenu dans le document UNEP/OzL.Pro/ExCom/73/35, paragraphe 76.

d'achat est plus élevé, mais cela ne réduira pas le coût de l'équipement. À ce stade, il est difficile de quantifier l'avantage du gain d'efficacité énergétique dans le calcul des surcoûts d'exploitation.

27. Le Secrétariat a noté en outre que les surcoûts d'exploitation comprenaient également les frais supplémentaires d'installation (21,31 \$US par unité), ce qui ne fait pas partie des coûts de production. En excluant les frais d'installation, les surcoûts d'exploitation sont de 20,64 \$US par unité. De plus, les surcoûts d'exploitation actuels pour l'unité à base de HC-290 sont calculés en fonction des productions par lots et sont susceptibles de diminuer une fois que la production complète démarrera et que la technologie sera perfectionnée. À l'heure actuelle, Midea et Guangdong Meizhi Co. poursuivent les recherches pour simplifier davantage les mesures de sécurité, comme l'élimination de la source d'ignition plutôt que l'installation de détecteurs de fuite au sein de l'unité. Étant donné que les surcoûts d'exploitation ne reflètent pas entièrement les surcoûts d'exploitation actuels du nouveau produit, l'ONUDI a accepté de continuer à faire le suivi du projet et de fournir des informations relatives aux surcoûts d'exploitation dans la fabrication de climatiseurs et de compresseurs à base de HC-290 à la 75^e réunion dans le rapport d'étape du PGEH du secteur de la climatisation en Chine.

28. Le Secrétariat a posé des questions sur les conditions ambiantes appropriées aux modèles actuellement développés et si ces derniers peuvent être utilisés à une température ambiante élevée. L'ONUDI a précisé que tous les produits dans le cadre du projet de démonstration ont été conçus pour une plage de température entre 18 °C et 43 °C. Après l'achèvement du projet de démonstration, Guangdong Meizhi Co. a développé des compresseurs conçus pour une plage de température entre 21 °C et 52 °C pour les régions où la température ambiante est élevée. La prochaine étape sera de concevoir des climatiseurs pour ces mêmes conditions.

29. Le principal obstacle restant à la pleine commercialisation des unités à base de HC-290 est le manque de normes pertinentes. Comme il est indiqué dans le rapport d'étape de la troisième tranche du plan pour le secteur de la climatisation², le gouvernement de Chine a entrepris l'élaboration des trois normes suivantes: les codes techniques de sécurité pour l'utilisation des réfrigérants inflammables dans l'industrie de fabrication des climatiseurs domestiques et similaires; les exigences de transport des climatiseurs individuels chargés de réfrigérants inflammables; et les codes techniques de sécurité pour la mise en service de l'équipement qui utilise des réfrigérants inflammables. L'adoption de ces normes est prévue en 2015. L'état des progrès dans l'élaboration de ces normes est indiqué dans le rapport d'étape du plan pour le secteur de la climatisation en Chine³.

Conversion de la chaîne de production de compresseurs chez Guangdong Meizhi Co.

30. En réponse à une question concernant le choix du lubrifiant, l'ONUDI a indiqué que le HC-290 se dissout bien dans tous les lubrifiants couramment utilisés, y compris l'huile minérale, l'huile alkylbenzène, polyolester et d'autres lubrifiants à forte polarité. Les propriétés du nouveau lubrifiant pour le HC-290 sont différentes de celles du lubrifiant traditionnellement utilisé avec le HCFC-22, ce qui a également donné lieu à des modifications de construction du compresseur.

Recommandations du Secrétariat

31. Le Comité exécutif peut souhaiter envisager les points suivants:

- (a) Prendre note du rapport final sur le projet de démonstration pour la conversion du HCFC-22 au propane chez Midea Room Air Conditioner Manufacturer Company et Guangdong Meizhi Co. en Chine, présenté par l'ONUDI et contenu dans le document UNEP/OzL.Pro/ExCom/73/17/Add.1;

² Le rapport d'étape sur la phase I du PGEH pour le secteur de la climatisation en Chine est contenu dans le document UNEP/OzL.Pro/ExCom/73/35, paragraphe 79.

³ Idem.

- (b) Demander aux agences bilatérales et d'exécution de tenir compte des informations contenues dans le rapport lors du soutien apporté aux pays concernés par l'article 5 dans la préparation de projets pour l'élimination du HCFC-22 dans le secteur de fabrication de climatiseurs individuels; et
- (c) Demander à l'ONUDI de continuer à faire le suivi du projet de démonstration et d'indiquer les surcoûts d'exploitation des climatiseurs et compresseurs à base de HC-290 à la 75^e réunion dans le cadre du rapport d'étape du plan pour le secteur de la fabrication de climatiseurs individuels du plan de gestion d'élimination des HCFC en Chine.

Chine: Rapport sur le projet de démonstration pour la conversion de la technologie à base de HCFC-141b en technologie à base d'isoparaffine et de siloxane (KC-6) pour le nettoyage dans la fabrication d'appareils médicaux chez Zhejiang Kindly Medical Devices Co. Ltd.

Contexte

32. Lors de sa 64^e réunion, le Comité exécutif a approuvé le projet de démonstration pour la conversion de la technologie à base de HCFC-141b en technologie à base d'isoparaffine et de siloxane (KC-6) chez Zhejiang Kindly Medical Devices Co. Ltd (KDL) en Chine. KDL se spécialise dans la fabrication de dispositifs médicaux à usage unique, en particulier différents types d'aiguilles, de canules et d'ensembles de veines du cuir chevelu jetables. En 2009, la production de l'entreprise représentait environ 45 pour cent de la production nationale de ces produits. Le projet a été approuvé dans le cadre du plan pour le secteur des solvants du PGEH en Chine. Le projet de démonstration visait à établir la pertinence de la technologie à base de KC-6 comme une solution de remplacement viable au HCFC-141b utilisé comme solvant dans la fabrication d'appareils médicaux. Il était prévu que les informations recueillies dans le projet de démonstration puissent être utilisées pour la conversion d'autres entreprises du secteur des solvants. Lors de la 73^e réunion, le PNUD a présenté le rapport final du projet de démonstration. Le rapport complet figure à l'annexe II du présent document.

Progrès

33. Les activités du projet comprenaient la conception du projet, l'installation de l'équipement, des modifications, la conversion de la chaîne de montage, des essais, des évaluations de performance et une formation. Un équipement de sécurité supplémentaire a été installé et des modifications/ajustements au processus de production ont été apportés en raison de l'inflammabilité du KC-6. Toutes les activités du projet pour la conversion ont été achevées à la fin de 2013. La chaîne de production est entrée en exploitation commerciale. Le projet a reçu l'acceptation nationale en décembre 2013. À la suite de la conversion, 27,82 tonnes métriques (tm) de HCFC-141b ont été éliminées.

Pertinence et performance de la technologie

34. Le projet de démonstration a révélé que le KC-6 présentait de bonnes propriétés de solvant pour l'huile de silicone et que le composé avec de l'huile de silicone fournissait une bonne qualité de revêtement sur la surface des dispositifs médicaux. Un certain nombre d'essais ont été réalisés pour évaluer la performance des aiguilles fabriquées en utilisant le KC-6 comme solvant. Les résultats ont montré que la qualité du nettoyage et la durabilité du produit répondaient aux exigences du produit. La force de perforation est légèrement supérieure à celle du HCFC-141b. La biocompatibilité et la pharmacocompatibilité ont aussi été testées et les résultats se sont révélés conformes aux normes nationales. La pertinence de la technologie à base de KC-6 comme une solution de remplacement du HCFC-141b utilisé comme solvant dans la fabrication d'aiguilles a donc été établie.

35. Le KC-6 a également une bonne performance environnementale. En plus de son PAO nul et de son potentiel de réchauffement planétaire inférieur à 20, il a également un point d'ébullition et une

stabilité chimique plus élevés que le HCFC-141b. Ces avantages permettent une gestion plus facile de la réduction des émissions et se traduisent par une consommation moindre.

Surcoûts

36. Les surcoûts en capital de 360 005 \$US pour la conversion sont similaires au montant approuvé de 352 051 \$US avec quelques variations dans les coûts des éléments individuels. En moyenne, le coût total de la conversion est de 2 pour cent supérieur au montant approuvé. Les surcoûts d'exploitation de 205 616 \$US ont été versés à l'entreprise. Le prix du KC-6 est de 6,80 \$US par kg.

Commentaires du Secrétariat

37. Le Secrétariat a posé des questions sur les effets du projet de démonstration sur l'élimination des HCFC dans le secteur des solvants. Le PNUD a répondu que le projet de démonstration a contribué au programme d'élimination pour ce secteur. Selon les résultats de cette démonstration, six entreprises ont choisi le KC-6 comme technologie de remplacement et ont signé des contrats sur l'élimination de la consommation de HCFC-141b dans la fabrication de dispositifs médicaux. La consommation totale de ces six entreprises s'élevait à 410 tm, ce qui représente 65 pour cent de l'élimination totale prévue pour la phase I du PGEH du secteur des solvants en Chine. Puisque KDL est la plus grande entreprise de production d'aiguilles avec une grande capacité de recherche et de développement technologique, de nombreux autres producteurs de dispositifs médicaux font confiance à KDL dans le choix des technologies. Un atelier sur la diffusion de la technologie a été organisé en juillet 2014 au cours duquel KDL a fourni des détails sur la conversion et a partagé son expérience dans la gestion des liquides de silicification et l'exploitation d'équipements optimisés pour obtenir des produits qualifiés.

38. Le Secrétariat a posé des questions sur les principales difficultés rencontrées lors de la conversion. Le PNUD a souligné l'inflammabilité du solvant et a suggéré de résoudre cette difficulté en utilisant des matériaux ignifuges, en ventilant l'atelier et en installant une alarme incendie et des systèmes de gicleurs. La formation des travailleurs est également nécessaire au fonctionnement sécuritaire de la chaîne de production.

39. Le Secrétariat a aussi posé des questions sur les problèmes relatifs aux brevets et à la disponibilité commerciale du KC-6. Le PNUD a indiqué que KDL ne détient aucun brevet lié à l'application du KC-6. Le KC-6 est développé par Beijing Aerospace Technology Innovation Co. Ltd. Ses principales composantes sont l'isoparaffine et le siloxane qui sont faciles à trouver sur le marché. Le KC-6 s'achète sur le marché au prix de 6,80 \$US par kg par rapport à 2,66 \$US par kg pour le HCFC-141b.

Recommandations du Secrétariat

40. Le Comité exécutif peut souhaiter envisager les points suivants:

- (a) Prendre note du rapport final sur le projet de démonstration pour la conversion de la technologie à base de HCFC-141b en une technologie à base d'isoparaffine et de siloxane (KC-6) chez Zhejiang Kindly Medical Devices Co. Ltd en Chine, présenté par le PNUD et contenu dans le document UNEP/OzL.Pro/ExCom/73/17/Add.1; et
- (b) Demander aux agences bilatérales et d'exécution de tenir compte des informations contenues dans le rapport lors du soutien apporté aux pays concernés par l'article 5 dans la préparation de projets pour l'élimination du HCFC-141b dans les applications de nettoyage médical du secteur des solvants.

Mondial: Options à faible coût pour l'utilisation d'hydrocarbures (HC) dans la fabrication de mousses en polyuréthane. Une évaluation de l'application des projets du Fonds multilatéral

Contexte

41. Lors de sa 58^e réunion, le Comité exécutif a approuvé un projet pour démontrer les options à faible coût pour l'utilisation des HC comme agent moussant dans la fabrication de mousses en polyuréthane en Égypte, mis en oeuvre par le PNUD (décision 58/31).

42. Lors de la 66^e réunion, le PNUD a présenté un rapport⁴ documentant la mise en œuvre du projet de démonstration, qui comprenait le développement de l'équipement, le développement du système, des essais par une entreprise de systèmes et des rapports par le biais d'un atelier interrégional pour diffuser les résultats, suivi par un rapport final au Comité exécutif. La démonstration a vérifié les propriétés physiques acceptables des produits rigides en mousse pour la réfrigération commerciale, les panneaux discontinus et les applications de chauffe-eau qui utilisent des systèmes à base de HC pré mélangés et des injections directes de HC. Elle a aussi montré que pour les systèmes à base de HC pré mélangés, des économies de coûts d'environ 100 000 \$US sont prévues en Égypte, puisqu'aucun système de mélangeur n'est nécessaire. Bien qu'il n'y ait pas d'économie de coûts de l'équipement dans le cas des injections directes, la conception compacte pourrait entraîner des économies dans la disposition et le stockage.

43. Selon la nécessité de fournir des informations supplémentaires sur plusieurs domaines, y compris la sécurité et les coûts, le Comité exécutif a décidé, entre autres, de demander au PNUD de finaliser les enquêtes supplémentaires sur les questions relatives à la sécurité, aux densités et à l'optimisation de l'équipement; de développer un concept de calcul des coûts en fonction des systèmes à base de HC pré mélangés; et de présenter un rapport complémentaire à la 67^e réunion (décision 66/15(s)).

Rapport d'étape et plan d'action

44. Lors de la 73^e réunion, le PNUD a présenté un rapport d'étape provisoire sur la mise en œuvre des activités supplémentaires en cours. Le PNUD travaille actuellement avec SAIP, le fabricant d'équipements, sur l'optimisation de la tête malaxeuse du distributeur; et avec une entreprise de systèmes sur l'étude d'un effet bénéfique possible de la densité du cyclopentane pré mélangé centralement ou directement injecté.

45. SAIP a développé une tête malaxeuse à trois voies améliorée qui a été montée sur le distributeur prototype existant. Les essais menés par l'entreprise de systèmes ont confirmé qu'il y avait des problèmes avec la densité de la mousse; mais d'autres essais n'ont pas pu être effectués en raison des difficultés techniques avec la tête malaxeuse. La tête malaxeuse sera modifiée en octobre 2014 afin de réaliser la dernière série d'essais. Les résultats des essais seront analysés en novembre et le rapport final sera présenté à la 74^e réunion.

Recommandations du Secrétariat

46. Le Comité exécutif peut souhaiter envisager les points suivants:

(a) Prendre note du rapport d'étape provisoire sur la mise en œuvre du projet de démonstration sur les options à faible coût pour l'utilisation d'hydrocarbures dans la fabrication de mousses en polyuréthane, présenté par le PNUD et contenu dans le document UNEP/OzL.Pro/ExCom/73/17/Add.1; et

(b)

⁴ UNEP/OzL.Pro/ExCom/66/17.

- (c) Demander au PNUD de présenter le rapport final du projet de démonstration à la 74^e réunion.

PARTIE V: RAPPORTS DE VÉRIFICATION FINANCIÈRE POUR LE HALON, LA PRODUCTION DE CFC, LA MOUSSE, L'AGENT DE TRANSFORMATION II, LES SOLVANTS ET LES SECTEURS DE L'ENTRETIEN DE LA RÉFRIGÉRATION À BASE DE CFC EN CHINE

Contexte

47. Lors de ses 56^e et 57^e réunions, le Comité exécutif a décidé, entre autres choses, de continuer à faire le suivi des activités et de l'utilisation des soldes des projets après la fin de l'entente pour les plans du secteur de production de CFC, de halon et de la mousse et pour les plans connexes du secteur d'élimination accélérée en Chine.⁵ Le rapport de vérification financière pour les années 2011 et 2012 a été présenté à la 71^e réunion. Le Comité exécutif a demandé, entre autres choses, des informations supplémentaires de la Banque mondiale sur les secteurs du halon, de la mousse, ainsi que les budgets pour l'utilisation des soldes de ces secteurs, et sur le secteur de la production de CFC (décision 71/12(b))⁶.

48. Par conséquent, la Banque mondiale, au nom du gouvernement de la Chine, a fourni un budget pour les soldes des fonds des secteurs de la production de CFC, de la mousse en polyuréthane (PU) et du halon à la 72^e réunion.

49. Lors de sa 72^e réunion, le Comité exécutif a examiné le rapport de vérification financière pour les plans du secteur de la mousse, de la production de CFC et du halon en Chine⁷ et a décidé d'inviter le gouvernement de la Chine, par l'entremise des agences d'exécution pertinentes, à présenter à la 73^e réunion les rapports de vérification financière pour les secteurs de l'agent de transformation II, des solvants et de l'entretien de la réfrigération à base de CFC, en plus des plans pour les fonds restants des secteurs du halon, de la production de CFC, de la mousse, de l'agent de transformation II, des solvants et de l'entretien de la réfrigération à base de CFC, en décrivant la façon dont ils seront utilisés par le gouvernement de la Chine pour les activités liées à l'élimination des PAO et pour permettre l'achèvement de ces plans sectoriels au plus tard à la fin de 2018 (décision 72/13(b)).

50. Conformément à la décision 72/13(b), le gouvernement de la Chine a présenté, par l'entremise des agences d'exécution pertinentes, les informations demandées, y compris les rapports de vérification financière de chaque plan sectoriel. Ces rapports ont été reçus seulement entre le 14 et le 17 octobre 2014. Avant leur présentation, le Secrétariat a été informé par les agences d'une demande du gouvernement de

⁵ Avec les procédures simplifiées suivantes: (a) La Chine présentera un plan de travail final pour le secteur de la mousse avec des informations sur les activités prévues et le financement associé. Chaque plan de travail indiquera les activités et le budget associé à mettre en œuvre en 2009 et ultérieurement, étant entendu que la Chine a la flexibilité pour faire les changements nécessaires à ces plans et qu'il ne lui sera pas nécessaire de présenter des plans de travail supplémentaires à moins que des modifications majeures leur soient apportées; (b) La Chine continuera à effectuer des vérifications financières indépendantes pour les trois plans sectoriels et ces vérifications seront fournies au Comité exécutif annuellement à compter de 2009; et (c) La Banque mondiale facilitera la révision et la présentation de tous les changements apportés aux plans de travail et aux rapports de vérification financière au Comité exécutif, et présentera les rapports d'achèvement du projet après la dépense finale de fonds (décision 56/13). Lors de sa 57^e réunion, le Comité exécutif a approuvé le plan de travail pour le secteur de la mousse en Chine pour 2010 à 2012 (décision 57/14(c)(i)).

⁶ Le Comité exécutif a décidé: « D'inviter le gouvernement de la Chine à fournir: (i) par l'entremise de la Banque mondiale, un rapport à la 72^e réunion expliquant la raison pour laquelle le rapport de vérification indiquait des soldes supérieurs à ceux des budgets approuvés aux 56^e et 57^e réunions pour les secteurs du halon et de la mousse en polyuréthane, et des informations sur la résolution de la question juridique identifiée dans le rapport de vérification à la 65^e réunion concernant le transport de halons récupérés jusqu'aux banques de halon à des fins de récupération et de recyclage demandé par la décision 65/10(i)(ii); (ii) par l'entremise de l'agence d'exécution pertinente, dans les futurs rapports de vérification financière en vertu de la décision 56/13, les données sur tous les fonds du Fonds multilatéral qui étaient détenus par le gouvernement de la Chine pour le décaissement en faveur des bénéficiaires finaux, ainsi que les intérêts courus de ces soldes détenus par le gouvernement de la Chine, y compris les données sur le plan du secteur de L'agent de transformation II, le plan du secteur des solvants et le plan d'entretien de la réfrigération; (iii) des informations complètes sur les progrès liés aux plans de travail pour les plans sectoriels et sa proposition sur la manière d'utiliser les soldes potentiels à des fins d'examen par le Comité exécutif à la 72^e réunion. »

⁷ Partie VI du document UNEP/OzL.Pro/ExCom/72/11/Add.1.

la Chine de présenter les rapports après la date prévue de présentation des documents au Secrétariat pour examen à la 73^e réunion.

51. Ce document contient les éléments suivants:

- (a) Les budgets prévus et les rapports d'étape pour l'utilisation du solde des fonds pour les secteurs du halon, de la production de CFC, de la mousse, de l'agent de transformation II, des solvants et de l'entretien de la réfrigération à base de CFC;
- (b) Le rapport de vérification financière du gouvernement de la Chine pour les secteurs susmentionnés;
- (c) Les intérêts générés par les projets sectoriels; et
- (d) Les observations et recommandations du Secrétariat.

52. Le tableau 2 présente les informations fournies en ce qui concerne les dates d'achèvement prévues, les rapports d'étape ou les descriptions de projet pour chaque activité, ainsi que le financement en date du 31 décembre 2009, comme il est indiqué dans la présente ou précédente documentation.

Tableau 2: Budgets prévus pour l'utilisation des fonds restants, les rapports d'étape et les dates d'achèvement

Article	Agence	Activité	Financement en date du 31 décembre 2009 (\$US)	Solde en date du 31 décembre 2013 (\$US)	Date d'achèvement prévue	Description du projet/progrès
Production de CFC						
1	Banque mondiale	Recrutement pour le soutien technique et organisation d'un atelier de technologie sur les solutions de remplacement, etc.	500 000	110 678	2014	Une variété d'activités, comme des consultations, des vérifications et des ateliers de formation, ont été réalisées. Les réalisations de l'application du Protocole de Montréal en Chine et l'évaluation de l'efficacité sur le plan environnemental ont été mises en œuvre et le dernier versement sera en 2014.
2	Banque mondiale	SIG des importations et exportations de PAO	500 000	45 590	2014	Un système de transmission de données spécifique a été établi entre le Bureau de gestion des importations et exportations de PAO et les douanes qui renforce davantage la capacité de gestion des importations et exportations de PAO. Les derniers 10 % seront versés à la fin de 2014.
3	Banque mondiale	Recherche et développement sur les solutions de remplacement des PAO	4 200 000	2 453 398	2016	Neuf propositions ont été retenues pour soutenir une partie des coûts de réalisation de ces activités de recherche et de développement. Le versement restant de 1 753 397,80 \$US sera effectué en 2014. Un montant supplémentaire de 700 000 \$US a été engagé pour financer de nouvelles recherches et de nouveaux développements sur les technologies de remplacement des PAO à faibles émissions de carbone.
4	Banque mondiale	Supervision et gestion		313 379	2018	Menée par le FECO pour assurer la conformité durable dans l'élimination des CFC.
5	Banque mondiale	Coûts d'exploitation pour le Centre de conformité en Chine	3 300 000	Non fourni	Non fourni	Non fourni
Total			8 500 000	2 923 044		Total global approuvé: 150 000 000 \$US
Secteur du halon						
1	Banque mondiale	Pénalité pour extincteur au CO ₂	1 200 000	1 200 000	2008	Alloué au renforcement des capacités de conformité en Chine
2	Banque mondiale	Conversion à la fabrication de système à base de halon 1301	339 840	339 840	2008-2009	Achevé et sans autre contrat

Article	Agence	Activité	Financement en date du 31 décembre 2009 (\$US)	Solde en date du 31 décembre 2013 (\$US)	Date d'achèvement prévue	Description du projet/progress
3	Banque mondiale	Clôture de la production de halon 1301 pour une consommation contrôlée	520 000	520 000	2009	Achevé
4	Banque mondiale	Activités de soutien technique, formation et activités de sensibilisation	900 000	900 000	2008-2010	Achevé
5	Banque mondiale	Activités de clôture du secteur du halon, examen d'achèvement du projet, audits, vérifications	300 000	300 000	2009-2010	Achevé
6	Banque mondiale	Activités centrales et provinciales de gestion et de mise en banque des halons	7 405 800	7 405 800	2008-2015	En cours
7	Banque mondiale	Gestion des halons, supervision, suivi, contrôle des utilisations de matière première, prévention de la production et de l'exportation illégales, etc.	1 500 000	1 500 000	2010-2015	En cours
Total			12 165 640	12 165 640		Total global approuvé: 62 000 000 \$US
Agent de transformation II						
1	Banque mondiale	Contrat d'élimination en cours		39 252	Fin de 2015	Deux contrats d'élimination en cours ont été signés avec deux entreprises avant 2010. Montant non décaissé de 39 252 \$US.
2	Banque mondiale	Renforcement de la capacité des bureaux de protection de l'environnement locaux.		2 410 000	Fin de 2017	Des ateliers, une formation, la sensibilisation du public, une collecte de données et une supervision seront mis en œuvre sur le plan provincial pour fournir des informations à jour et les politiques actuelles concernant la gestion des PAO contribueront à assumer les responsabilités en matière d'application. Six bureaux de protection de l'environnement où se trouvent d'autres producteurs de CTC et de PAO ont été choisis pour la mise en œuvre du projet.
3	Banque mondiale	Élimination des résidus de CTC		5 700 000	Fin de 2018	L'élimination des résidus de CTC (classé comme un déchet dangereux) a été une difficulté pour la plupart des producteurs. Il y a un manque de technologie et de capacité d'élimination des déchets dangereux pour le gouvernement local. Afin de résoudre le problème, un projet a été proposé pour sélectionner des centres d'élimination des déchets dangereux et des producteurs de CTC pour les soutenir dans l'établissement d'une capacité d'élimination des résidus de CTC, y compris l'équipement, la technologie, le système de gestion et une élimination concentrée d'une manière sécuritaire et respectueuse de l'environnement dans certaines régions.
4	Banque mondiale	Nouvel agent de transformation potentiel répertorié par la réunion des parties, élimination du CTC pour les usages en laboratoire, étude et évaluation des technologies et des solutions de remplacement.		1 500 000	Fin de 2018	Appuyer l'enquête et les activités d'élimination sur la nouvelle utilisation potentielle de l'agent de transformation du CTC; examiner les normes pertinentes, développer des solutions de remplacement pour le CTC pour les usages en laboratoire. Examiner et évaluer les solutions et les technologies de remplacement qui ont été utilisées et qui seront utilisées, et évaluer les conséquences sociales, économiques et environnementales de ces substituts

Article	Agence	Activité	Financement en date du 31 décembre 2009 (\$US)	Solde en date du 31 décembre 2013 (\$US)	Date d'achèvement prévue	Description du projet/progress
5	Banque mondiale	Suivi, gestion et évaluation finale		402 292	Fin de 2018	Le CTC comme un sous-produit dans la production de CMS est introduit dans le système de gestion à long terme. Par conséquent, un mécanisme de gestion efficace du CTC est nécessaire, ce qui demandera des consultations, des formations, une évaluation, un audit et une vérification.
Total			Non fourni	10 051 544		Total global approuvé: 46 500 000 \$US
Mousse en PU						
1	Banque mondiale	Sélection et évaluation des substituts sans CFC et développement de nouveaux substituts	2 660 000	1 570 000	2016	Dix propositions de projet ont été retenues et recommandées pour financement à l'appui des activités de recherche sur l'agent de soufflage de la mousse pour développer de nouveaux agents sans PAO ou à faible PRP afin de satisfaire les propriétés isolantes et le prix plus bas pour les PME; et sur le polyol pré mélangé contenant des agents de soufflage de remplacement pour optimiser la stabilité et la performance, et améliorer la conductivité thermique de la mousse.
2	Banque mondiale	Activités provinciales supplémentaires sur la mousse (renforcement de la capacité pour 11 provinces)	3 100 000	2 640 000	2016	
3	Banque mondiale	Service technique pour l'entreprise de mousse pour une meilleure application des solutions de remplacement	1 400 000	1 400 000	2016	Le FECO a divulgué un avis public invitant les entreprises de systèmes à fournir un soutien technique aux entreprises de mousse. Après l'évaluation, un certain nombre d'entreprises de systèmes ont été choisies. Le plafond du contrat de chaque entreprise est inférieur à 350 000 \$US.
4	Banque mondiale	Suivi continu de l'élimination du CFC dans le secteur de la mousse	1 050 000	1 050 000	2017	Le FECO soutient quatre principales provinces, soit Hebei, Henan, Shandong et Tianjin, où se trouvent la plupart des entreprises de mousse et des entreprises de systèmes, en visitant les fournisseurs de produits chimiques, les entreprises de systèmes et les entreprises de mousse pour recueillir des échantillons d'agents de soufflage, des polyols pré mélangés et des produits de mousse finaux, et en effectuant une inspection des matières premières utilisées par les entreprises.
5	Banque mondiale	Suivi et gestion du projet		706 414	2017-2018	
Total			8 923 000	7 366 414		Total global approuvé: 53 846 000 \$US
Entretien de la réfrigération						
1	L'ONUDI, le Japon et le PNUE	Programme de formation		500 000	Déc. 2016	Le FECO a créé huit centres pour mettre en œuvre des cours de formation professionnelle pour les techniciens d'entretien dans huit villes dont la consommation de réfrigérants est élevée.
2	L'ONUDI, le Japon et le PNUE	Effets de l'évaluation sur le programme de formation		150 000	Déc. 2017	Un grand nombre de techniciens ont déjà été formés et devraient être formés dans la période de 2014 à 2016.
3	L'ONUDI, le Japon et le PNUE	Traitement des PAO		900 000	Déc. 2017	Renforcement de la capacité de récupération, de recyclage et d'élimination des CFC par l'achat d'équipement et par la récupération des déchets de CFC. Il y a un manque de capacité pour le traitement (récupération, recyclage et élimination) des déchets PAO

Article	Agence	Activité	Financement en date du 31 décembre 2009 (\$US)	Solde en date du 31 décembre 2013 (\$US)	Date d'achèvement prévue	Description du projet/progress
4	L'ONUDI, le Japon et le PNUE	Étude des données		170 000	Déc. 2016	Une étude est prévue sur les stations de démantèlement de navires pour évaluer la récupération/recyclage de CFC en 2015-2016. D'autres sous-secteurs, comme la climatisation mobile, les réfrigérateurs et la climatisation/réfrigération, seront également pris en compte dans l'étude. Il y a un grand nombre de navires hors service qui doivent être éliminés ou démantelés chaque année; par conséquent, 200 équipements de récupération des PAO ont été achetés et distribués aux stations de démantèlement de navires sélectionnées.
5	ONUDI	Suivi et gestion		95 846	Déc. 2017	Suivi et gestion des activités, y compris des consultations, des formations, une évaluation et une vérification qui seront effectuées par le FECO. Suivi continu des activités
6				949 329		
Total			746 313	2 765 175		Total global approuvé: 7 884 853 \$US
Secteur des solvants						
1	PNUD	Lutte contre les activités illégales associées aux PAO: renforcement de la capacité pour 10 bureaux de douane locaux		2 100 000	2017	Dix bureaux de douane ont été choisis pour mener à bien le renforcement de la capacité. Le FECO prévoit continuer à former les agents des douanes afin de renforcer leur capacité à lutter contre les activités illégales d'importation et d'exportation de PAO de manière efficace et en temps opportun.
2	PNUD	Renforcement de la capacité du personnel lié aux PAO dans 14 provinces		3 400 000	2017	Des ateliers, une formation, la sensibilisation du public, une collecte de données et une supervision seront mis en œuvre sur le plan provincial pour fournir des informations à jour et les politiques actuelles concernant la gestion des PAO aux autorités locales pour qu'elles assument les responsabilités en matière d'application. Le fonds alloué soutiendra ces activités dans 14 provinces, chaque année, pour au moins 700 participants des bureaux de protection de l'environnement locaux, d'autres ministères liés aux PAO, des associations industrielles et des entreprises.
3	PNUD	Sensibilisation du public et activités publicitaires		700 000	2017	Le FECO renforcera la sensibilisation du public sur la protection de la couche d'ozone en particulier dans le secteur des solvants.
4	PNUD	Recherche et publication de politiques		200 000	2017	Le FECO procédera à une évaluation des impacts environnementaux sur les solvants de remplacement, y compris les impacts sur la qualité de l'air en présence de composés organiques volatils, et mettra au point une publication qui résumera les avantages sociaux et environnementaux de l'élimination des PAO.
5	PNUD	Recherche et évaluation de la technologie de remplacement		760 000	2016	Le FECO a retenu quatre propositions de projet pour la recherche et la sélection de substituts sans PAO pour les applications électroniques et métallurgiques sans PAO et à faible PRP; et des solutions de remplacement au diluant de polysiloxane méthylé et hydrogéné pour les entreprises de dispositifs médicaux.
6	PNUD	Système de gestion des dossiers électroniques		400 000	2017	Le FECO prévoit établir un système de gestion électronique pour les documents liés aux PAO. Le FECO a élaboré et mis en œuvre 25 plans sectoriels et a accumulé des documents de projet, comme des contrats, des documents d'approvisionnement, des rapports d'étape et des documents relatifs aux décaissements et aux demandes de fonds.
7	PNUD	Suivi et gestion de projet		578 467	2018	Suivi et gestion de projet, y compris des réunions de formation, une vérification et une évaluation de la mise en œuvre.
Total			12 712 381	8 138 467		Total global approuvé: 52 000 000 \$US

53. Des vérifications financières ont été réalisées par Daxin Chartered Public Accounts selon les normes nationales. L'opinion d'audit était que les déclarations de dépenses et de subventions étaient conformes aux normes comptables de la Chine et qu'elles ont été présentées équitablement et justement à tous les égards importants du 1^{er} janvier 2010 au 30 juin 2014 par le FECO/MEP. Les vérificateurs ont confirmé les soldes en date du 31 décembre 2013 qui sont présentés au tableau 2.

54. Le tableau 3 présente le montant des intérêts perçus.

Tableau 3: Intérêts déclarés des plans sectoriels en Chine (\$US)

Plan sectoriel	2010	2011	2012	2013	Janv. - juin 2014	2010 - juin 2014	Perçus en date du 31 déc. 2012
Production de CFC, halon, mousse en PU et agent de transformation II	1 672	2 026	2 083	2 568	1 412	9 761	1 526 277*
Solvants	42 421	62 461	57 569	49 817	22 832	235 100	Non fourni
Entretien de la réfrigération	8 086	15 472	16 583	14 341	6 732	61 214	Non fourni

*Fourni dans le rapport de vérification en date du 31 décembre 2012 pour la production de CFC, le halon et la mousse en PU seulement.

Commentaires du Secrétariat

55. Les agences d'exécution ont présenté les rapports de vérification demandés en indiquant la façon dont les soldes restants seraient utilisés par activité et secteur, et elles ont fourni des rapports d'étape pour tous les articles, excepté 11. Toutefois, il n'était pas précisé si les activités avaient été amorcées. Les informations du rapport d'étape pour ces articles ont été demandées, y compris la résolution de la question juridique identifiée dans le rapport de vérification présenté à la 65^e réunion sur la capacité de transport des halons récupérés aux banques de halons à des fins de récupération et de recyclage (conformément à la décision 65/10(i)(ii)).

56. Les activités achevées avaient un solde restant de 1 452 090 \$US, mais l'information sur la manière dont ces fonds seraient utilisés n'a pas été fournie. Les intérêts cumulés n'ont pas été fournis dans le cadre du rapport de vérification présenté à cette réunion et, par conséquent, ils ont été demandés pour les secteurs de l'agent de transformation II, de l'entretien de la réfrigération et des solvants.

57. Le tableau 4 présente des informations sur les soldes en cours et intérêts courus pour les plans sectoriels de la Banque mondiale et de l'entretien de la réfrigération. Le niveau des intérêts courus par le secteur de l'entretien dépasse significativement ce rapport pour les plans sectoriels de la Banque, alors que les plans sectoriels de la Banque ont des soldes courants plus importants. Le Secrétariat a demandé des éclaircissements à ce sujet.

Tableau 4: Soldes courants et intérêts perçus pour les plans sectoriels en cours d'exécution par la Banque mondiale et pour le secteur de l'entretien de la réfrigération

Article	Cumulatif en date du 31 déc. 2009 (\$US)	2010 (\$US)	2011 (\$US)	2012 (\$US)	2013 (\$US)	Janv. - juin 2014 (\$US)	Cumulatif (\$US)
Soldes courants (tous les secteurs de la Banque)	59 063 212	49 003 536	44 313 004	39 088 842	35 864 676	32 548 865	
Intérêts (Banque mondiale)	Non fourni	1 672	2 026	2 083	2 568	1 412	9 761
Soldes courants (entretien de la réfrigération)	746 313	2 469 519	3 112 783	3 143 117	2 814 062	2 765 175	
Intérêts (ONUDI, Japon et PNUE)	Non fourni	8 086	15 472	16 583	14 341	6 732	61 214

58. Le Comité exécutif sera informé lors de la 73^e réunion des informations supplémentaires qui devront être fournies aux agences d'exécution pertinentes en réponse aux questions soulevées par le Secrétariat.

Recommandations du Secrétariat

59. Le Comité exécutif peut souhaiter envisager les points suivants:

- (a) Noter avec satisfaction les rapports de vérification financière, les plans de travail et les rapports d'étape fournis pour les secteurs de la production de CFC, du halon, de la mousse en polyuréthane (PU), de l'agent de transformation II, de l'entretien de la réfrigération et des solvants en Chine, contenus dans le document UNEP/OzL.Pro/ExCom/73/17/Add.1;
- (b) Demander ce qui suit au gouvernement de la Chine et aux agences bilatérales et d'exécution pertinentes:
 - (i) Présenter des rapports d'étape annuels, des rapports de vérification et les intérêts courus pendant la mise en œuvre des plans sectoriels de la production de CFC, du halon, de la mousse en PU, de l'agent de transformation II, de l'entretien de la réfrigération et des solvants jusqu'à l'achèvement de toutes les activités connexes prévues au plus tard le 31 décembre 2018, et
 - (ii) Présenter des rapports d'achèvement de projet pour les plans sectoriels de la production de CFC, du halon, de la mousse en PU, de l'agent de transformation II, de l'entretien de la réfrigération et des solvants au Comité exécutif au plus tard à la première réunion de 2019.

PARTIE VI: LES PLANS NATIONAUX D'ÉLIMINATION DU CFC

La République islamique d'Iran: Mise en œuvre du plan national d'élimination du CFC: politique et composante réglementaire

Contexte

60. Lors de sa 41^e réunion (décembre 2003), le Comité exécutif a approuvé un montant de 100 000 \$US plus les coûts d'appui d'agence pour le PNUE pour la mise en œuvre d'une politique et d'une composante réglementaire du plan national d'élimination du CFC pour la République islamique d'Iran (IRA/PHA/41/TAS/161). En septembre 2004, le PNUE a signé un protocole d'entente avec le gouvernement pour la mise en œuvre de ces activités et a transféré un total de 90 000 \$US à cette fin. Bien que toutes ces activités ont été mises en œuvre, seulement 30 000 \$US des 90 000 \$US qui avaient été transférés ont été comptabilisés par le gouvernement.

Commentaires du Secrétariat

61. Le PNUE a présenté un rapport sur le paiement non comptabilisé de 60 000 \$US lors de la 73^e réunion, conformément à la décision 72/16. Dans son rapport, le PNUE a indiqué que depuis 2008, le PNUE effectue un suivi constant de cette affaire par le biais de communications officielles et de discussions bilatérales avec les représentants du gouvernement. Cependant, en date de la 73^e réunion, un rapport sur le paiement non comptabilisé de 60 000 \$US par le gouvernement n'a pas été fourni. Par conséquent, le PNUE a proposé de retourner les 60 000 \$US du financement de 262 000 \$US approuvé pour le PNUE pour la mise en œuvre de la composante du secteur de l'entretien de la réfrigération de la phase I du plan de gestion d'élimination des HCFC lors de la 63^e réunion (IRA/PHA/63/TAS/200), étant

entendu que les activités correspondantes seront mises en œuvre avec les propres ressources du gouvernement de la République islamique d'Iran.

Recommandations du Secrétariat

62. Le Comité exécutif pourrait envisager de noter le retour des 60 000 \$US, lors de la 74^e réunion, pour la composante du secteur d'entretien de la réfrigération de la phase I du plan de gestion d'élimination des HCFC (PGEH) de la République islamique d'Iran qui n'ont pas été comptabilisés dans le plan national d'élimination du CFC (IRA/PHA/63/TAS/200), étant entendu que les activités correspondantes du PGEH seront mises en œuvre avec les propres ressources du gouvernement.

Les Philippines: Rapport financier pour le plan national d'élimination du CFC (PNEC)

Contexte

63. Lors de la 72^e réunion, le Comité exécutif, pendant l'examen du rapport financier présenté par le PNUE au nom du gouvernement des Philippines, a décidé, entre autres choses, de demander au gouvernement des Philippines, par l'entremise du PNUE, de présenter au Secrétariat, au plus tard le 30 juin 2014, le rapport financier officiel vérifié pour le plan national d'élimination du CFC (PNEC) aux Philippines dûment signé par un vérificateur indépendant ou accrédité par le gouvernement (décision 72/14(c)).

Rapport de vérification financière

64. La vérification financière (présentée le 16 juillet 2014) portait sur les transactions et les opérations de l'Unité de gestion des projets (UGP) du PNEC à compter du 1^{er} janvier 2013 jusqu'au 31 mai 2014. Les vérificateurs ont signalé que les états financiers fournis par l'UGP et la documentation à l'appui étaient conformes aux lois et règles applicables et aux principes comptables généralement reconnus. Sur le montant total de 801 630 \$US approuvé pour le reste des activités du PNEC, 786 218,37 \$US ont été décaissés par le gouvernement à la fin de décembre 2013. Le solde de 15 411,63 \$US doit être remis au Fonds multilatéral lors de la 73^e réunion.

Commentaires du Secrétariat

65. Le PNUE a confirmé que la vérification menée pour le PNEC était conforme aux exigences des règles et règlements comptables des Nations Unies. Elle est donc considérée comme étant acceptable.

66. Le Secrétariat a noté en outre que dans la décision 72/14(d)(i), le Comité exécutif, entre autres choses, a demandé au PNUE d'assurer la remise de tout solde non dépensé en fonction du rapport des vérificateurs au Fonds multilatéral au plus tard à la 73^e réunion. Ces soldes n'ont pas été remis en date de la rédaction du présent document.

Recommandations du Secrétariat

67. Le Comité exécutif peut souhaiter envisager les points suivants:

- (a) Prendre note du rapport financier vérifié pour le plan national d'élimination du CFC aux Philippines présenté par le PNUE au nom du gouvernement des Philippines et contenu dans le document UNEP/OzL.Pro/ExCom/73/17/Add.1;
- (b) Demander au PNUE de retourner le solde de 15 411 \$US, plus les coûts d'appui d'agence, le plus rapidement possible, au plus tard à la 74^e réunion, conformément à la décision 72/14(d)(i); et

- (c) Noter que le PNUE présentera le rapport d'achèvement de projet pour le projet en question au plus tard à la 74^e réunion, conformément à la décision 72/14(d)(ii).

PARTIE VII: PROJET D'ÉLIMINATION DU BROMURE DE MÉTHYLE (BrM) AU GUATEMALA

Contexte

68. Lors de sa 71^e réunion, le Comité exécutif a demandé à l'ONUDI de présenter un rapport d'étape sur l'interdiction des importations des utilisations contrôlées de BrM en date du 1^{er} janvier 2015 et des mesures prises pour assurer la viabilité à long terme des technologies de remplacement, étant donné le fait que la consommation de 2012 était supérieure à celle autorisée par l'entente avec le Comité exécutif. Compte tenu de ce qui précède, l'ONUDI a présenté un rapport conforme à la décision 71/7(b)(i).

Rapport d'étape

69. Le rapport d'étape de l'ONUDI a indiqué que plusieurs activités ont été mises en œuvre pour quatre des cinq entreprises utilisant le BrM (une des entreprises est entièrement détenue par une capitale non-A5), y compris l'approvisionnement et l'installation de l'équipement, des ateliers pratiques sur le greffage, la formation des techniciens des universités agricoles et des instituts de recherche, ainsi que le soutien technique à l'institut agricole de Zapaca. Le programme d'étude des étudiants en horticulture sera mis à jour pour inclure les agents biologiques, le greffage et l'utilisation responsable du fumigant. Les activités prévues pour le reste de la période de mise en œuvre comprennent l'approvisionnement d'équipement supplémentaire pour le greffage, des ateliers supplémentaires et des formations sur le greffage, les agents biologiques, le *Monosporascus* et ses mesures de contrôle, ainsi qu'une visite sur le terrain au Mexique. Toutes ces activités contribueront à la viabilité à long terme des technologies de remplacement dans le pays. De plus, le gouvernement du Guatemala a émis une interdiction sur l'importation des utilisations contrôlées du BrM au Guatemala qui sera en vigueur à compter du 1^{er} janvier 2015.

Commentaires du Secrétariat

70. En examinant le rapport de l'ONUDI, le Secrétariat a noté un fort engagement du gouvernement du Guatemala à se conformer aux mesures de contrôle contre le BrM: le gouvernement a émis une interdiction sur l'importation des utilisations contrôlées du BrM en vigueur à compter du 1^{er} janvier 2015; la remise de 210 000 \$US des fonds approuvés dans le cadre de la deuxième tranche de l'ONUDI et 35 000 \$US des fonds approuvés pour le PNUE sur 70 000 \$US. Plusieurs activités, y compris l'approvisionnement d'équipement, des ateliers et des formations aux parties concernées ont été réalisées. Toutes ces actions assureront la viabilité à long terme des technologies de remplacement.

Recommandations du Secrétariat

71. Le Comité exécutif peut souhaiter envisager les points suivants:
- (a) Prendre note du rapport d'étape sur la mise en œuvre du projet d'élimination du bromure de méthyle (BrM) présenté par l'ONUDI au nom du gouvernement du Guatemala et contenu dans le document UNEP/OzL.Pro/ExCom/73/17/Add.1; et
 - (b) Demander à l'ONUDI et au PNUE de présenter, lors de la 74^e réunion, un rapport d'étape et un rapport sur tout risque potentiel de non-conformité pour 2015.

PARTIE VIII: ÉLIMINATION ET GESTION DES DÉCHETS PAO

Indonésie et les Philippines: Rapports finaux des projets d'élimination des PAO

Contexte

72. Lors de la 57^e réunion, le Comité exécutif a approuvé des fonds pour la préparation de projets de démonstration pilotes sur l'élimination et la gestion des déchets PAO en Indonésie et aux Philippines. Lors de cette réunion, la Banque mondiale a indiqué que ces fonds seraient utilisés pour générer des données et tirer de l'expérience sur les modalités de gestion et de financement, et qu'elle examinerait les possibilités de tirer parti d'un cofinancement.

73. La Banque mondiale a présenté les rapports finaux contenant des éléments qui décrivent les inventaires de déchets PAO actuels en Indonésie et aux Philippines, des informations sur la manière de faire des inventaires et des collectes de données, des conseils sur la gestion des PAO indésirables, des options de financement pour la destruction des PAO indésirables, y compris des informations sur les marchés disponibles, des considérations financières et la valeur marchande. Les rapports contiennent également des options spécifiques pour chaque pays, une évaluation de ces options et les prochaines étapes nécessaires à la mise en œuvre. Ces rapports sont joints en annexe IV.

Commentaires du Secrétariat

74. En examinant ces rapports, le Secrétariat a noté les informations détaillées qui y sont contenues et leur utilité, en particulier les manuels préparés pour l'Indonésie et les Philippines. Le Secrétariat a noté en outre que les conseils fournis dans ces documents aideront les pays concernés par l'article 5 à comprendre leur situation actuelle en ce qui concerne les déchets PAO et les options qui s'offrent à eux en matière de gestion et d'élimination.

Recommandations du Secrétariat

75. Le Comité exécutif peut souhaiter envisager les points suivants:

- (a) Prendre note des rapports présentés par la Banque mondiale sur les projets d'élimination des PAO en Indonésie et aux Philippines contenus dans le document UNEP/OzL.Pro/ExCom/73/17/Add.1; et
- (b) Demander aux agences bilatérales et d'exécution d'examiner les informations contenues dans ces rapports au moment de donner des conseils aux pays concernés par l'article 5 sur la gestion et l'élimination des déchets PAO.

Région de l'Europe et de l'Asie centrale (EAC): Démonstration d'une stratégie régionale sur la gestion et l'élimination de déchets PAO

Contexte

76. Lors de la 69^e réunion, le Comité exécutif a approuvé la mise en œuvre d'un projet régional pour développer et démontrer une stratégie de gestion et d'élimination de déchets PAO dans la région de l'Europe et de l'Asie centrale⁸ (EAC) pour la mise en œuvre de l'ONUDI et du PNUE, étant entendu qu'un rapport complet serait présenté, fournissant des informations sur les quantités actuelles de déchets PAO recueillies par substance à compter de l'approbation du projet à la 73^e réunion (décision 69/19(b)(ii)).

⁸ Les pays participant à ce projet sont la Bosnie-Herzégovine, la Croatie et le Monténégro.

77. Le rapport présenté a indiqué qu'une quantité totale de 25,13 tonnes métriques de déchets PAO a été recueillie par des centres de récupération et de recyclage participant au projet en date de la présentation. La quantité restante de 3,94 tonnes métriques qui doit être détruite sera recueillie au dernier trimestre de 2014 et éliminée dans la première moitié de 2015.

Commentaires du Secrétariat

78. À la demande du Secrétariat, l'ONUDI a indiqué que les quantités de déchets PAO qui ont été recueillies jusqu'à présent provenaient de trois centres de récupération et de recyclage en Croatie et l'origine des 3,94 tonnes métriques de déchets restants n'a pas encore été déterminée. L'ONUDI a également indiqué que la capacité d'agrégation d'un centre de récupération et de recyclage en Bosnie-Herzégovine et au Monténégro a été améliorée grâce à l'approvisionnement d'outils et d'équipement. Le renforcement de la capacité se poursuit dans ces trois pays et l'ONUDI est persuadé que les objectifs de ce projet seront atteints.

Recommandations du Secrétariat

79. Le Comité exécutif peut souhaiter envisager les points suivants:

- (a) Prendre note du rapport présenté par l'ONUDI sur les quantités actuelles de déchets PAO recueillis par substance pour la démonstration d'une stratégie régionale sur la gestion et l'élimination des déchets PAO dans la région de l'Europe et de l'Asie centrale, conformément à la décision 69/19(b)(ii) contenu dans le document UNEP/OzL.Pro/ExCom/73/17/Add.1; et
- (b) Demander à l'ONUDI et au PNUE de présenter un rapport d'achèvement de projet à l'achèvement du projet de démonstration pilote, au plus tard à la première réunion de 2016.

PARTIE IX: LA MOBILISATION DES RESSOURCES

Mondial: Mobilisation des ressources pour atteindre des cobénéfices climatiques

Rapport final

80. Lors de sa 63^e réunion, le Comité exécutif a approuvé un montant de 100 000 \$US afin que le PNUE puisse entreprendre une étude sur les options de financement, les ateliers régionaux sur le cofinancement ou une ou plusieurs applications pilotes de cofinancement pour un ou plusieurs pays à faible volume de consommation ayant un plan de gestion d'élimination des HCFC, un montant qui sera financé comme des activités de mobilisation des ressources.

81. Le PNUE a fourni le rapport final du projet de mobilisation des ressources par la présentation d'un document intitulé Options de financement pour atteindre des cobénéfices climatiques pour l'élimination des HCFC dans les pays à faible volume de consommation dans le secteur de l'entretien seulement. Le document fournit des directives pour les spécialistes de l'ozone dans les pays à faible volume de consommation sur la manière de rechercher du financement en dehors du Fonds multilatéral pour atteindre les cobénéfices climatiques liés à leur PGEH. Le rapport contient des informations sur la situation des pays à faible volume de consommation, un article sur les solutions de remplacement des HCFC à faible PRP pour le secteur de l'entretien, une brève description des principales sources de soutien financier qui peuvent être disponibles pour atteindre les cobénéfices climatiques et se termine par des directives étape par étape destinées aux spécialistes de l'ozone qui cherchent à profiter des cobénéfices climatiques pendant l'élimination des HCFC.

Commentaires du Secrétariat

82. En examinant le rapport, le Secrétariat a demandé au PNUE de préciser le processus ou la méthodologie selon lequel le rapport est préparé et la manière dont les résultats des ateliers régionaux réalisés ont été pris en compte dans le document final. Le Secrétariat a aussi fourni des commentaires sur le format du rapport et a proposé quelques modifications qui donneraient plus de clarté à la présentation.

83. Le Secrétariat a également noté que des éléments qui étaient nécessaires dans le cadre du projet (p. ex. l'additionnalité, la transparence, l'évitement des incitations insidieuses, le partage des bénéfices, l'assurance de la durabilité, l'évitement de doublons et les informations sur les coûts de transaction) n'étaient pas inclus dans le rapport. Le Secrétariat a également rappelé au PNUE d'autres décisions pertinentes pour la mobilisation des ressources, y compris l'analyse de l'évaluation du projet des refroidisseurs et la manière dont les aspects spécifiques pourraient être pris en compte dans les rapports finaux, le cas échéant.

84. À la suite de discussions avec le PNUE, un projet final révisé a été présenté en tenant compte des observations et des commentaires du Secrétariat, ainsi que des éléments en suspens indiqués dans le paragraphe 83 ci-dessus. Ce rapport final est joint en annexe V.

Recommandations du Secrétariat

85. Le Comité exécutif peut souhaiter envisager les points suivants:

- (a) Prendre note du rapport sur la mobilisation des ressources pour atteindre des cobénéfices climatiques présenté par le PNUE et contenu dans le document UNEP/OzL.Pro/ExCom/73/17/Add.1; et
- (b) Encourager les pays à faible volume de consommation, par le biais des agences bilatérales et d'exécution, à suivre les directives fournies dans le rapport lors de la recherche de ressources supplémentaires pour atteindre des cobénéfices climatiques pendant la mise en œuvre de la phase I et des phases futures des plans de gestion d'élimination des HCFC.

DEMONSTRATION PROJECT FOR CONVERSION FROM HCFC-22/HCFC-142b TECHNOLOGY TO CO₂ WITH METHYL FORMATE CO-BLOWING TECHNOLOGY IN THE MANUFACTURE OF XPS FOAM AT FEININGER (NANJING) ENERGY SAVING TECHNOLOGY CO. LTD.

FINAL REPORT

August, 2014

Submitted by:

Foreign Economic Cooperation Office, Ministry of Environmental Protection, China (FECO/MEP)

and

United Nations Development Programme (UNDP)

Executive Summary

Demonstration project for conversion from HCFC-22/HCFC-142b technology to CO₂ with methyl formate co-blowing technology in the manufacture of XPS foam at Feininger (Nanjing) Energy Saving Technology Co. Ltd. was approved by the 64th Executive Committee meeting at a funding level of US\$ 1,973,300.

This demonstration project was successfully implemented, and established the suitability of methyl formate co-blowing technology as a viable replacement of the currently used HCFC-22 / HCFC-142b in the manufacture of XPS foam at Feininger (Nanjing) Energy Saving Technology Co. Ltd.

The project activities includes product redesign and development, equipment installation and modifications safety, laboratory testing and performance evaluation, product trials, production line conversion, technical assistance and training.

The successful completion of the demonstration project showed that the methyl formate co-blown with CO₂ exhibited the industrial feasibility in the production of XPS foam board. XPS foam board produced by this conversion technique can be used for frost insulation of roads, railways, trafficked areas, light weight fill for reduction of horizontal and vertical earth pressure and other civil engineering applications etc.

1. Introduction

The Demonstration Proposal prepared and submitted to the 62nd ExCom meeting. And the Executive Committee approved the XPS Demonstration project in 64th meeting in July 2011 at a funding level of US \$ 1,973,300. The project's implementing agency is UNDP. The national agency implementing this project is Foreign Economic Cooperation Office (FECO), Ministry Of Environmental Protection, China.

The objective of this demonstration project is to establish the suitability of CO₂ with methyl formate co-blowing technology as a viable replacement of the currently used HCFC-22/HCFC-142b blowing agent in the manufacture of XPS foam at Feininger (Nanjing) Energy Saving Technology Co. Ltd.

The successful implementation of this demonstration project will provide an environment friendly and cost-effective alternative for enabling replication of this technology in similar applications and enterprises in the XPS Foam Sector, and result in reductions in HCFC consumption of 12.3 ODP tones, contributing to compliance with the 2013/2015 control targets in China. It will also lead to net annual emission reductions of 420,250 tonnes CO₂-eq.

1.1 Background

The XPS Foam Sector in China has experienced remarkable growth in the past several years. Due to the steep growth in the construction industry, demand for XPS foam boards for building thermal insulation has increased significantly, ascribed also to enhanced energy-efficiency standards for buildings. The 2009 estimated HCFC consumption in the sector was about 41,000 metric tonnes. Based on information from surveys, there are about 20 indigenous manufacturers of XPS extrusion lines and an estimated 500 manufacturers of XPS foam in the sector.

Another defining characteristic of this sector is that most of the polystyrene raw material used in XPS foam manufacturing originates from recycled polystyrene scrap with aim to reduce the production cost. Recent zero-ODP XPS foam technologies introduced by multinational corporations are expensive and have been closely guarded in terms of intellectual property, for example complex cell technology used isobutene as blowing agent by Kaneka Corporation and pure CO₂ foaming technology by Dow Corporation. Due to this, these technologies are not cost-effectively accessible for most of XPS foam enterprises of China and may not be compatible to

operate with a high proportion of recycled polystyrene scrap. There is, thus, a clear and present need for a cost-effective and environmentally safe technology alternative for the XPS foam sector of China, in order to remain sustainable and maintain product quality.

Feininger (Nanjing) Energy Saving Technology Co. Ltd. was established in 2002 and it is one of the major manufacturers of Extruded Polystyrene (XPS) foam and XPS foam machines in China. The enterprise also manufactures XPS foam boards with thickness from 20 mm to 100 mm. Other products include Extruded Polyethylene (XPE) foam boards and sheets, XPS foam pipe sections and PVC pipes. Feininger currently employs 143 persons, of which about 50 are technical.

Feininger has been recognized as one of the leading companies in the XPS industry in China with excellent management and high quality products. The enterprise has 26 patents, covering almost all the core technologies in XPS manufacturing. Feininger has been identified as a national high technology enterprise. It has obtained the Class-A Tax Credit Certification Award promulgated by the Internal Revenue Service and the Local Taxation Bureau of Nanjing, Jiangsu. It has also obtained ISO 9000, ISO14001 and CE certifications.

The enterprise currently operates two XPS foam manufacturing lines, both built in-house. The main technical parameters of the baseline equipment in these two manufacturing lines are tabulated below:

Parameter	Unit	Line 1/ SE 150/200*	Line 2/TE 75/200
Type	N/A	Single/Single Tandem	Twin/Single Tandem
Capacity	kg/hr	480-720	480-720
	m ³ /day	300-450	300-450
Diameter of primary extruder	Mm	SE 150	TE 75
Diameter of secondary extruder	Mm	SE 200	SE 200
Power of primary extruder	kW	110	110
Power of secondary extruder	kW	75	75
Connected load	kVA	250	250
Electrical supply	Volts	380V/3 Ph/50 Hz	
XPS board thickness	Mm	20-100	
XPS board width	Mm	600, 900, 1200	
Blowing agents	N/A	HCFC-142b/22 (50:50)	HCFC-142b/22,142b
HCFC consumption**	Metric tonnes	205	290

*Line 1/ SE 150/200 have been converted to non-HCFC technology in this demonstration project.

** 2010

The manufacturing line 1/SE 150/200 is a primary single-screw extruder/single-screw tandem extrusion system and line 2/TE 75/200 is a twin-screw extruder/single-screw tandem extrusion system. Compared with the primary single-screw (line 1), the primary twin-screw (line 2) has some advantages, such as steadier feeding, better dispersive and distributive mixing and better temperature control capability. These characteristics result in XPS foam with lower density and better insulation value. In the past three years, due to demand for improved product standards, the line 2/TE75/200 twin-screw system has been used for a larger share of the production. The existing extrusion line 1/SE 150/200 comprises of the following main equipment:

- Primary extruder 150 mm (36:1)
- Secondary extruder 200 mm (34:1)
- Pre-blending system for additives
- Two single stage blowing agent pumps delivering to the primary extruder
- Static mixer at the discharge of the secondary extruder
- Extrusion die and shaper
- Interconnecting piping and fitting
- Controls and indications

Feininger has rich experience in manufacturing a wide range of XPS foam-related products including the full range of XPS processing equipment. The enterprise has been engaged in research and development in XPS foams, XPS manufacturing machinery and auxiliary equipment such as XPS recycling machines, for several years. The enterprise also has technically competent staff and good management and is financially sound. It has a good market recognition and reputation. Any technology successfully adopted at Feininger provides a good opportunity for wider and more effective dissemination and adoption by the downstream users of XPS machinery and equipment provided by Feininger.

Based on these considerations, Feininger was considered to be the most suitable and appropriate for carrying out this demonstration project.

1.2 Technical Choice

The main zero-ODP alternatives to HCFCs for the XPS foam sector include HFCs, CO₂ and Hydrocarbons. However, these technologies require a high level of process optimization and changes, significant investments up to several million dollars, and are closely guarded in terms of intellectual property rights by a very few large multinational corporations and can be potentially used by only very large enterprises under license or as subsidiaries of these corporations. The introduction of these alternative technologies is therefore a difficult challenge for the Chinese XPS foam industry. The challenge is to develop an alternative technology that can be environmental-friendly, easy and stably used by the large number of XPS foam enterprises in China, particularly because high levels of polystyrene scrap is used as raw material. This is critical because the sector is experiencing a high growth due to rapidly increasing demand in building and other infrastructural construction uses in China.

The selected technology for demonstration is CO₂ and methyl formate co-blowing technology for the following reasons:

- CO₂ has zero ODP and GWP of 1, with a low cost and wide availability in China. It is also non-flammable and stable. It is thus favorable in terms of environment, health and safety. However CO₂ has a small molecule and tends to diffuse through the polymer structure quite easily. The insulation performance with CO₂ alone is therefore not favorable. CO₂ also requires high-pressure operation. Thus, CO₂ alone is not suitable and requires a co-blowing agent.
- Methyl formate is an industrial chemical which is widely and cost-effectively available. The thermal conductivity of methyl formate is low (10.7 m-W/m-K), which is quite close to that of HCFC-142b and HCFC-22 (10 m-W/m-K and 11 m-W/m-K) respectively and much better as compared with other co-blowing agents such as ethanol (17.1 m-W/m-K) and HFC-152a (13.6 m-W/m-K). The co-blowing of methyl formate with CO₂ is thus expected to lead to a lower thermal conductivity of XPS foam as compared with CO₂ alone or co-blown with ethanol or HFC-152a. Additionally, the combination will have very low GWP.

Methyl formate has a boiling point of 32°C giving rise to some concerns on dimensional stability of XPS foam boards at room temperature. In order to customize and improve the physical, mechanical, thermal and flammable properties of the XPS foams to bring them on par with the current HCFC technology, a third co-blowing agent will need to be introduced, for example HFC-152a. The boiling point of HFC-152a is -24.7°C, which is favorable to the dimensional stability and the thermal resistance of the XPS board.

2. Project Implementation

The project was approved by 64th Executive Committee meeting in 2011 at a funding of US\$ 1,973,300. The

project implementation started at 2012, the conversion project was completed in June 2014.

According to the project implementation plan, the following activities were carried out: the retrofitting plan evaluation, procurement, equipment installation and commissioning, pilot running, properties testing, industrial feasibility assessment etc.

2.1 Extrusion foaming line retrofitting

Based on the implementation plan, Feininger updated its original production line to new twin screw extruder tandem single screw extruder line. The high accurate material gravimetric feeder and blowing agent injection and metering system, the high automated downstream parts were equipped with the new line.



Feeder and gravimetric dosing system for PS resin



Blowing agent tank and diaphragm pump metering system



Extrusion foaming extruder and the downstream parts

2.2 Ventilation and fire safety systems retrofitting

The ventilation and fire safety systems of the production workshop were retrofitted and also came into use. An external safety audit was carried out to ensure that the safety systems were consistent with local regulations.



Forced ventilation system and highly sensitive flammable gas sensor



Fire equipment and anti-explosive control cabinet

2.3 Commissioning/Trial-production

Co-blowing system comprising of CO₂/Methyl formate, CO₂/Methyl formate/Ethanol were choose as the substitutes for the HCFC-22/HCFC-142b. The effect of those new blowing systems on the processing process and the properties of the XPS foam board were evaluated. By use of CO₂/Methyl fomate blowing system, the XPS foam board was manufactured in the new line to verify the industrial feasibility. Some special formula was introduced to assess the stability and reliability of the production in the commissioning process.





Commissioning/Trial-production by use of the CO₂/Methyl formate co-blowing agent

2.4 XPS board properties testing

The XPS foam board from the new line was delivered to specialized laboratory to test properties. The thermal resistance of the board was compared in the below table.

Testing Item	Standard	Unit	50/50 CO ₂ /EtOH	50/50 CO ₂ /Methyl Formate	50/20/30 CO ₂ /EtOH/Methyl formate
Thermal conductivity	GB/T 10294-2008	W/m.K	0.0345	0.0342	0.0336



XPS board properties testing and the relevant test report

2.5 Process and safety training

Process and safety training were provided to the manufacturing, installation and maintenance personnel from August 2013 to December 2013.

To ensure the production safety, Feininger retrofitted the ventilation and fire safety systems of the workshop, which comprised the forced ventilation system, the static protection system, the highly sensitive detection, alarm and control system for flammable and explosive gas, the emergency power supply system etc.

Feininger invited a lot of polymeric foam processing experts to conduct training. Feininger had carried out almost 60 person/time of technical training on the research staff, the technical and safety training for equipment operators. Feininger compiled a safety production booklet for using methyl formate and ethanol in the production of XPS foam board and would like to share with other enterprises.

Process and safety training were provided to the manufacturing, installation and maintenance personnel. It was verified that the internal technical acceptance were completed and technical commissioning and relevant personnel training were finished.



XPS board Processing training and fire safety training

2.6 Management

The project was under the overall management and coordination of the Foreign Economic Cooperation Office, Ministry of Environmental Protection of China. UNDP was the implementing agency for the project, which provided international coordination and technical assistance.

The project employs the Performance-based Payment (PBP) mechanism in its implementation. Under the PBP mechanism, the enterprise tasked to carry out the conversion would play the role as a key executor, which is responsible for all the activities related to the conversion. The procurement was organized fully in line with the marketing principle to ensure cost-effective and timely installation of equipment for CO₂ based manufacturing operations.

FECO and UNDP were not involved in the procurement activities of the enterprise by any means other than make payment to the enterprise in tranches for the costs of procurement and conversion, at agreed payment dates given in the payment schedule, and when milestones prerequisite for the tranche have all been achieved on time.

Before each payment, FECO invited independent experts to verify whether the performance for each milestone that the payment depends on have been satisfying. The verification reports were submitted and accepted by UNDP as the main supporting documents for requesting the installment of payment.

During project implementation, FECO and UNDP organized 5 verification missions combined with monitoring and evaluation at Feininger (Nanjing) factory - once in 2011, once in 2012, 2 times in 2013 and once in 2014. The experts group included technology experts and finance experts, FECO staff and UNDP staff as well. The experts team traced the project implementation situations, evaluated the project technical issues and progress, and verified whether the performance for each milestone that the payment depends on have been satisfied. Each verification activity was carried out in a process of planning, preparation, data confirmation, technical material checking, on-the-spot investigation, result confirmation and conclusion.

3. Outcomes

The project was implementing smoothly according to the program schedule, and was completed in June 2014. The national acceptance will be completed by the end of 2014. The production line is running commercially, and IOC will be disbursed to enterprise in 2015. The industrial application feasibility of methyl formate together with CO₂ and ethanol in the production of XPS foam board has been well verified.

The following are the salient outcomes of the project.

- The enterprise completed the redesign of extruder production line, foaming agent injection control system and fire safety system in 2012.
- Equipment for extruder production line was procured in 2012.
- The fire safety system and explosion-proof retrofit were completed in 2013.
- Technical commissioning was completed successfully and relevant personnel were trained in 2013.
- The project Completion verification has been carried out in June 2014.

4. Technical performance

Technical performance of the XPS foam manufactured after implementation of conversion technology is given below.

- CO₂ has zero ODP and GWP of 1, with a low cost and wide availability in China.
- CO₂ is non-flammable and stable. It is thus favorable in terms of environment, health and safety.
- Methyl formate is an industrial chemical which is widely and cost-effectively available.
- The thermal conductivity of methyl formate is low, which is quite close to that of HCFC-142b and HCFC-22 respectively.
- The co-blowing of methyl formate with CO₂ was thus expected to lead to a lower thermal conductivity of XPS board as compared with CO₂ alone or co-blown with ethanol if the processing process could not be severely influenced.
- Methyl formate could be used as the co-blowing agent of CO₂ basically. Using methyl formate as the co-blowing agent of CO₂ had no significant influences on the processing process of XPS board.

5. Project management and monitoring

5.1 Project progress

The project was implementing smoothly according to the program schedule, and was completed in June 2014. The national acceptance will be completed by the end of 2014. The capacity of the production line has been converted to use substitute Foaming agent.

Each of milestones was achieved and verified, the details are as follows:

Milestones		Status
1st	Project Contract to be signed with enterprise	FECO and the enterprise signed contract in March 2012
2 nd	Feininger (Nanjing) sign the procurement contracts with conversion equipment suppliers	Finished in October 2012
3 rd	Conversion equipment was installed in KDL	Finished and verified in January 2013
4 th	The trial run of conversion equipment was verified by expert team	Finished and verified in December 2013
5 th	The enterprise submitted the completion report	Finished in May 2012
6 th	Completion verification was organized by FECO and UNDP	Finished in June 2012

5.2 Conversion cost

Total Project Costs:

The total contract amount with the enterprise is US\$1,844,635, including ICC US\$1,557,635, and IOC US\$287,000.

Incremental Capital Costs:

The actual incremental capital costs for conversion was US\$1,743,186, among which US\$ 1,557,635 was funded by MLF, and US\$185,551 was co-financed by the enterprise. The details of ICC are as follows:

No.	Item/Description	Grant funds (US\$)	Counterpart funds(US\$)	Actual cost (US\$)
1. Extruder Retrofitting				
1.1	Extruder Retrofitting	565,000	99,516	664,516
1.2	Extrusion die (include die heating control system)	15,000	15,484	30,484
1.3	Static mixer	25,000	-2,419	22,581
1.4	Foaming agent injection control system and Explosion-proof retrofit	142,000	-37,161	104,839
Subtotal		747,000	75,420	822,420
2. Blowing agent supply system				
2.1	Storage tank with accessories for CO ₂ , methyl formate, third blowing agent, CO ₂ metering system and Blowing agent piping (high and low pressure)	130,000	-9,516	120,484
2.3	Methyl formate and the third blowing component injection and metering system	160,000	17,186	177,186
Subtotal		290,000	7,670	297,670
3. Ventilation and fire safety system				
3.1	Fire safety system design	10,000	-4,355	5,645
3.2	Transformation of ventilation system and Fire safety system	326,000	55,452	381,452
Subtotal		336,000	51,097	387,097
4. Other				
4.1	Technology transfer from external process expert	25,000	15,323	40,323
4.2	Process trials and safety training	75,000	103,728	178,728
4.3	Product evaluation and certification	10,000	2,271	12,271
4.4	External safety audit	5,000	-323	4,677
Subtotal		115,000	120,999	235,999
5.Contingency		69,635	-69,635	
Total		1,557,635	185,551	1,743,186

Incremental Operating Costs:

The agreed total incremental operating costs calculated one-year duration amount to US\$287,000. The production line is running commercially, and the IOC will be disbursed to enterprise in 2015. The data of IOC is preliminary value.

The cost for the baseline HCFCs based two-stage systems are summarized as below:

- In the HCFCs technology:
 1. HCFC-22 /142b price is US\$ 1.9 /kg
 2. Raw material (reclaimed materials) price is US\$ 1.45 /kg
- In the CO₂ technology:
 1. CO₂ price is US\$ 0.11/kg
 2. Methyl formate price is US\$ 2.25 /kg
 3. Raw material (new PS resin materials) price is US\$ 1.8 /kg

Incremental Operating Cost Source	HCFCs technology		CO ₂ technology	
	consumption in one year(kg)	Cost(US\$)	consumption in one year(kg)	Cost(US\$)
HCFC-22 /142b	200,000	380,000	-	
CO ₂	-		120,000	13,200
Methyl formate	-		80,000	180,000
Raw material	2,000,000	2,900,000	2,000,000	3,600,000
Total		3,280,000		3,793,200

Based on the above table, the actual incremental operating cost on a yearly basis is estimated to US\$513,200.

6. Impact

6.1 Environmental Impact

The HCFC consumption in 2010 at Feininger (Nanjing) Energy Saving Technology Co. Ltd. was 495 metric tonnes. The successful implementation of this demonstration project on one manufacturing line has resulted in a reduction of HCFC consumption by 205 metric tonnes.

The ODP, GWP and MW data of HCFC-142b/-22, CO₂ and Methyl Formate are tabulated below.

Substance	ODP	GWP	Molecular weight
HCFC-142b/22 (50:50)	0.06	2050	93
CO ₂	0	1	44
Methyl formate	0	0	60

The successful implementation of this demonstration project on one manufacturing line has resulted in a reduction of HCFC consumption by 205 metric tonnes. Taking into account both ODP and GWP values of HCFCs, the successful implementation of this project will result in an annual reduction of a minimum of 12.3 ODP tonnes and annual emission reductions of 420,250 tonnes CO₂-eq.

6.2 Results

The successful implementation of this project will result in the following:

- (a) Sustainable reductions in HCFC consumption in the XPS sector in China of 12.3 ODP tonnes, contributing to China's compliance with the 2013 and 2015 control targets.
- (b) Demonstration and availability of an environmentally safe and cost-effective alternative for enabling replication of this technology in similar applications and enterprises in the XPS Foam Sector in China.
- (c) XPS foam board produced by this conversion technique can be used for frost insulation of roads, railways, trafficked areas, light weight fill for reduction of horizontal and vertical earth pressure and other civil engineering applications etc.

UNITED NATIONS INDUSTRIAL DEVELOPMENT ORGANIZATION



Demonstration Sub-Project for Conversion from HCFC-22 to Propane
at Midea Room Air-conditioner Manufacturing Company

Demonstration Sub-Project for Conversion of Room A/C Compressor
Manufacturing from HCFC-22 to Propane at Guangdong Meizhi Co.

FINAL REPORT

Table of Contents

Executive summary	3
1. Introduction	6
2. Project objectives	7
3. Implementation	8
3.1. Selected production lines	8
3.2. Projects activities and scope of the work	8
3.2.1. Midea.....	8
3.2.1 Meizhi	16
4. Results	22
4.1. Environmental impact	22
4.2. Quality of the new products	23
5. Incremental costs.....	25
5.1. Incremental capital costs	25
5.1.1. Midea.....	25
5.1.2. Meizhi	25
5.2. Incremental operating costs.....	26
6. Safety issues	27
7. Practical findings/Lessons learnt.....	28
8. Conclusions	30
ANNEX 1. Cost of equipment purchased - Midea.....	32
ANNEX 2. Actual costs – Meizhi.....	39

Executive summary

This project was developed as response to the Decision 55/43 of the Multilateral Fund Executive Committee and is part of a limited group of projects with the objective to assess new technology options that use non-ODP and low GWP refrigerants; this project was specifically approved by Decision 61/32 in July 2010.

Propane (R-290) is an environmentally friendly refrigerant, since its ODP is zero and its GWP is as low as three. With an excellent cooling performance, R-290 is considered one of the ideal alternatives to replace HCFC-22 in the Room Air Conditioning (RAC) sector. However, since this refrigerant is different from HCFC-22 in terms of chemical and physical properties, thermal performance and flammability, the application of R-290 refrigerant requires design and structural modifications of the HCFC-22-based products and production lines.

In this sense, and in order to support the implementation of its HCFCs phase-out plan in the RAC sector, China (an article 5 party) prepared, in cooperation with UNIDO, two demonstration sub-projects for the conversion of RAC units and compressors manufacturing from HCFC-22 to R-290, in two leading companies' production lines: Guangdong Midea Refrigeration Equipment Co. Ltd. and Guangdong Meizhi Co. Ltd.

In the case of Midea, the production line that has been converted is an advanced mechanized line with complete manufacturing functions, consisting of assembly line, charging equipment, vacuum pump, running test system, leak detectors, packing machine as well as other specialized machines. The products manufactured on the line include split units working with AC and DC. The baseline production is 200,000 units per year.

With regard to Meizhi, the selected production line has an annual production capacity of 1,830,000 HCFC-22-based units that are applied in split air-conditioners of 1 hp and 1.5 hp. Within the selected line there are altogether five component manufacturing departments, that is: 1) roughing and finishing of rollor, cylinder, blade, and crankshaft and bearing components of the compression structure; 2) case manufacturing department for the production of main shell and upper and lower shells; 3) Production of stator and rotor of the compressor motor; 4) Motor coil manufacturing, and 5) Assembly department for sorting, matching, assembly, painting lubricant charging, sealing, tightness, electrical and performance testing.

From these two projects the following conclusions can be pointed out:

- With an excellent cooling performance, R-290 is considered one of the ideal alternatives of HCFC-22 in the RAC sector after conversion of production lines.
- R-290 is available in the Chinese market.
- The conversion of two of the most important production lines of RAC units and compressors in China has maintained the quality and performance of the appliances produced by these two companies. Their performance is consistent with national (CCC) and international standards (IEC/CB and CE), and this has already been certified by the authorities.
- In order to obtain such improvements in the new products' performance, as well as in the system optimization, significant additional efforts were required in terms of co-financing by both companies.
- Regarding the new compressors' performance, the energy efficiency is 2%-3% higher than HCFC-22 compressors.
- Concerning the new RAC units' performance, the energy efficiency is 5%-12% higher than HCFC-22 air-conditioners.
- Further efficiency improvement both in compressors and AC units could be achieved if the charge sizes specified in international standards were relaxed, since there is a relationship between charge and efficiency. Until then, efficiency improvement is mainly dependent on the actual R&D - invested in the product in the past several years and the years to come - and also on system optimization, which was required as in most refrigeration conversion activities in the past.
- **Two types of R-290 compressors (fixed and variable frequency) with 1 HP and COP of 4.12-4.33** are available for mass production after the conversion of the production line.
- **Two types of R-290 RAC units (split/VF and portable A/C) and six different models** are also available for mass production after conversion.
- The conversion of production lines and the manufacturing of new appliances can be handled safely, despite the flammability of R-290, if appropriate measures are implemented and appropriate tools and equipment are used.
- Developments continue post-project with the aim to minimize and simplify product modifications while maintaining safety; as well as to reduce the refrigerant charge in order to expand the range of products.
- The experiments and assessments show that the possibility of fire and explosion for a wall-mounted R-290 air-conditioner is only 10^{-8} - 10^{-9} per year under household use conditions in China. Nevertheless, the next stages of phase-out programme should focus on risks in the servicing and installation processes, risks at different charges, and secondary risks from a fire.

- Besides, in order to foster the introduction of this new technology in the Chinese market it is necessary to establish new policies and financial measures, as well as updated safety standards.

Incremental capital costs

- In the case of both Midea and Meizhi, the projects have had higher capital costs than the agreed project budget.

Incremental operating costs

- Regarding Midea's project, the estimated IOC for one split unit is currently US\$ 41.95. Although the actual IOC is significantly higher than the eligible USD 6.3/kg, these additional costs are associated with the product initiation and expected to decrease in future, albeit not quite the level of the IOC threshold. In addition, the methodology for applying the safety measures is also being refined.
- The cost of the new compressor manufactured by Meizhi is US\$ 7.57 higher than the HCFC-22 based compressor (cost already part of the above calculation). IOC for compressor for Midea was not covered by the funds provided by the MLF, instead the conversion of Meizhi compressor manufacturing line was financed.

The approval and implementation of these demonstration projects was key for the development of R290 units and was a basis for the RAC phase-out strategy in China. As a result, by now, most RAC manufacturers in China are involved in R290 conversion activities and R&D.

While these demonstration projects in China were successful, the application of hydrocarbon (HC) technology should be carefully evaluated in context of the local situation prevailing in each country. The report by no means concludes that the technology was sufficiently consolidated to be applied in all countries, and did not address issues of availability and cost in the field. Finally, interested parties must take into consideration the proprietary issues related to the technology.

1. Introduction

In 2007, the 19th Meeting of the Parties of the Montreal Protocol agreed on accelerating the phase-out of HCFCs. To achieve the compliance goal, China is implementing a HCFCs phase-out sector plan in the Room Air Conditioning (RAC) sector since 2012. In order to support the implementation of this sector plan, China prepared, in cooperation with UNIDO, two demonstration projects (hereafter, the projects) for the conversion of RAC and compressors manufacturing from HCFC-22 to propane (R-290), in two different companies: Guangdong Midea Refrigeration Equipment Co. Ltd. and Guangdong Meizhi Co. Ltd.

The Executive Committee (ExCom) approved the Midea and Meizhi projects at the 61st ExCom meeting, with a budget of US\$ 4,026,507 and US\$ 1,875,000, respectively. UNIDO has been the implementing international agency of the two projects, while the Foreign Economic Cooperation Office of China (FECO), which is part of the Ministry of Environmental Protection, has been the national implementing agency.

Guangdong Midea Refrigeration Equipment Co., Ltd was jointly funded by Guangdong Midea Electric Appliances Inc. (80%) and Toshiba-Carrier Corporation (20%) in 2000. Midea is a large-scale enterprise focusing on the development, production, sales and after-sales service of domestic, commercial and central air-conditioners. As one of the leading manufacturers in the RAC sector of China, Midea has altogether 75 RAC production lines and the annual production capacity amounts to 20,000,000 units.

Guangdong Meizhi Refrigeration Equipment Company Co., Ltd is a comprehensive technology-oriented compressor manufacturer established in September 1995. It is owned by Guangdong Midea Electric Appliances Group (60% share) and Toshiba (40% share). Meizhi belongs to the refrigeration business group of Midea, and it is specializing in the production, sale, and R&D of domestic compressors, mainly for RAC appliances, but also for refrigeration.

Since these two companies are joint ventures shared by local and foreign companies, the budget allocated by the ExCom covers the associated costs of the projects in the same proportion as the local ownership, that is: 80% in the case of Midea and 60% in the case of Meizhi. For this reason, co-financing was needed to cover the rest of the associated costs.

The conversion projects in these two companies were developed as response to the Decision 55/43 (b) of the Multilateral Fund Executive Committee, which is intended to select projects that best demonstrated alternative technologies and facilitated the collection of accurate data on incremental capital costs and incremental operating costs or savings, as well as other data relevant to the application of the technologies. They are also part of a limited group of projects with the objective to assess new technology options that use refrigerants with zero ozone depleting potential (ODP) and low global warming potential (GWP).

2. Project objectives

R-290 is an environmentally friendly refrigerant, since its ODP is zero and its GWP is as low as three. With an excellent cooling performance, R-290 is considered one of the ideal alternatives of HCFC-22 in RAC sector. However, since this refrigerant is different from HCFC-22 in terms of chemical and physical properties, thermal performance and flammability, the application of R-290 refrigerant necessitates design and structural modifications of the HCFC-22-based products and their production lines.

Table 1. Physical properties of R-290 compared to HCFC-22

Parameters	HCFC-22	R-290
Molecular formula	CHCLF ₂	C ₃ H ₈
Molecular weight	86.5	44.1
Critical temperature °C	96.2	96.8
Critical pressure (MPa)	4.99	4.25
Boiling point (°C)	-40.8	-42.1
Lower flammable limit (v%)	N	2.1
Burning velocity (cm/s)	N	39
Combustion heat (KJ/mol)	N	2217.8
GWP	1700	3
ODP	0.055	0

In this sense, these projects consist of the conversion of two HCFC-22-based production lines of both split room air-conditioners and compressors, to R-290 technology¹, with no capacity increase and quality upgrade, in order to:

- Promote the replacement of HCFC in RAC manufacturing sector;
- Demonstrate redesign of split RAC units and compressors for the use of R-290 refrigerant;
- Seek solutions and obtain experience in safe conversion of production lines, refrigerant storage and handling facilities,
- Demonstrate alternative production techniques in air-conditioner and compressor manufacturing;
- Undertake training and marketing of RAC appliances and compressors using R-290 refrigerant;
- Elaborate techniques and processes as well as to collect experience in transportation and installation of R-290 split RACs;
- Support the testing and verification of the conversion of manufacturing of HCFC-22-based compressors to R-290-based compressor and;

¹ Refrigerant R-290 is currently available in the Chinese market.

- Accumulate and disseminate experience for future technical conversion projects.

With the conversion of Meizhi's production line, the new compressors will indirectly phase out 2,196 metric tons of HCFC-22, with an impact of 121 ODP tons per year. In the case of Midea, the new RAC units will phase out 240 metric tons per year, with an impact of 13.2 ODP tons per year.

3. Implementation

3.1. Selected production lines

In the case of Midea, the production line that has been converted is an advanced mechanized line with complete manufacturing functions, consisting of assembly line, charging equipment, vacuum pump, running test system, leak detectors, packing machine as well as other specialized machines. The products manufactured on the line include split unit working with AC and DC. The production line met quality and safety requirements and its baseline production was 200,000 units per year.

The company produces most of the components, including heat exchangers. The compressors are purchased from Meizhi compressor factory.

In the case of Meizhi, among the eleven domestic RAC compressor production lines of the company, it has been converted the one with an annual production capacity of 1,830,000 HCFC-22-based units. The compressors of this line are applied in split air-conditioners of 1 hp and 1.5 hp. Within the selected line there are altogether five component manufacturing departments:

- Roughing and finishing of rollor, cylinder, blade, and crankshaft and bearing components of the compression structure;
- Case manufacturing department for the production of main shell and upper and lower shells;
- Production of stator and rotor of the compressor motor;
- Motor coil manufacturing and;
- Assembly department for sorting, matching, assembly, painting lubricant charging, sealing, tightness, electrical and performance testing etc.

3.2. Projects activities and scope of the work

3.2.1. Midea

After the project was approved in July 2010, FECO and UNIDO signed a contract in May 2011 for its implementation. After 30 months implementation, the conversion project was completed by the end of 2013, and all equipment and lab facilities were installed and tested. Midea has developed different types of A/C products for domestic and oversea markets. It entrusted the national quality supervision and inspection center and the provider of technical services TUV to carry out product test. The test focused

especially on the safety of products. The R-290 A/C has received the China Compulsory Certificate (CCC), the IEC/CB certificate, and the CE certificate.

The following activities were carried out in the implementation: production line planning, conversion of product testing unit, modification of production process, product redesign and development, set-up of prototype and training².

The residential air conditioner research and development center of Midea was responsible for the overall coordination and management of the project implementation.

Production line planning

Capacity of R-290 production line

The R-290 production line was converted from an existing HCFC-22 line. The capacity of this production line will be 200,000 units annually. It can produce outdoor units, including VF, for split A/C of 1.5HP and below, portable A/C, window A/C and dehumidifiers.

Location and construction plan

The old line was located in a plant with other 6 lines. Considering the flammability of R-290, the company decided to select a new production site, separated from other lines. In this sense, it was decided that the production line would be moved to the second floor of No9 plant building. The size of the new production area is 1,800 m², from previously around 1,000 m², but this increase in the operating area is not related to the flammability of R-290, neither is it to any increase in production capacity.

Conversion of production line

The following conversions and modifications were carried out to the production line:

² Transportation, installation and servicing of R-290 AC units are part of an ongoing R&D project under the Stage I HPMP of the RAC sector.

Table 2. Conversion of production line - Midea

No.	Equipment	Contents of Conversion
1	Assembly Line	<ul style="list-style-type: none"> • Relocation of the equipment to new site • Modification of production process (modification of line structure and work station) • Explosion-proof modification and antistatic measurements
2	Running Test system	<ul style="list-style-type: none"> • Function test units adjusted to the properties of R-290 • Explosion-proof modification • Modification to the operation room
3	Vacuum inspection system	<ul style="list-style-type: none"> • Explosion-proof modification to inspection systems • Modification to inspection program
4	Refrigerant Supply line	<ul style="list-style-type: none"> • Installation of R-290 supply equipment • Installation of transport piping of R-290 • New storage tank for R-290 • Lighting protection to the supply station
5	Vacuum pump	<ul style="list-style-type: none"> • Explosion-proof motor • Explosion-proof modification to rework area
6	Vacuum chamber helium leak detection	<ul style="list-style-type: none"> • Explosion-proof modification
7	Refrigerant Charging	<ul style="list-style-type: none"> • AGRAMKOW PROMAX-F2 charging machine, include pressure booster and safety systems
8	Leak detectors	<ul style="list-style-type: none"> • INFICO leak detector
9	Ventilation system	<ul style="list-style-type: none"> • The ventilation system was composed of 4 independent sub-systems, including product testing area, production line, operating room and refrigerant supply station. Each sub system has 2 double speed exhaust fan. When one fan malfunctioned, another fan will be switched on automatically.
10	Alarm system	<ul style="list-style-type: none"> • Drager alarm system. The system has 15 infrared gas detectors and sensors. It is able to detect the concentration of flammable gas of the production line, the refrigerant supply station and the product testing area.
11	Sealing machine	<ul style="list-style-type: none"> • LOKRING pneumatic sealing
12	Tools and fixtures	<ul style="list-style-type: none"> • Quick connector, improve safety level

The layout of the production line is shown in the picture below:

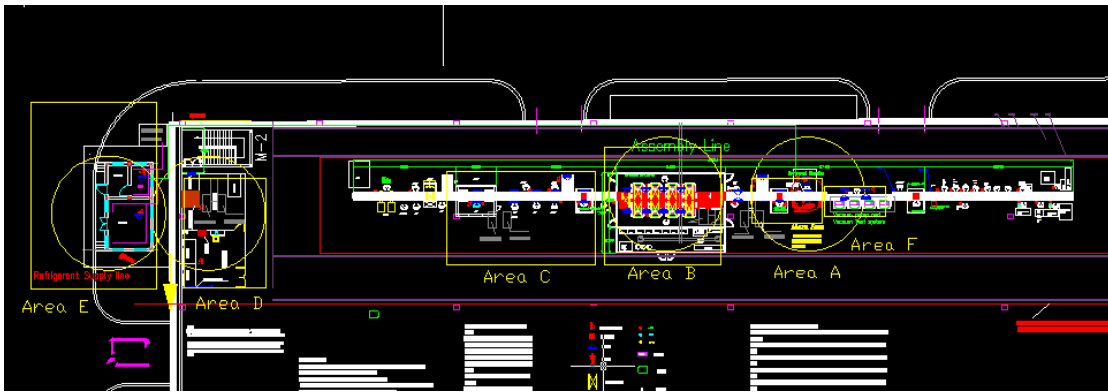

Picture 1. Layout of the production line.

Area A: refrigerant charging area

Area B: performance testing area

Area C: leakage detecting and final testing area

Area D: products inspection area

Area E: refrigerants supply station

Area F: other assembly

Regarding the modification of production process in the assembly line, the structure remained the same with some differences, mainly related to the safety measures required for the R-290. After the assembly of the units, there is a N₂/H₂ pressure and leak test to control the tightness of the assembled unit, followed by evacuation of the units. After this, charging takes place followed by a leak test, which includes a repair area. Then, there is a sealing (ultrasonic welding or Lokring) function test, followed by a leak test and packaging. In hazardous areas (charging, repair, testing areas) there are dedicated ventilation systems and enclosures to avoid spreading R-290 in case of a leak.

Concerning the running test system, a new function test room was built with R-290 indoor units, antistatic floor, proper ventilation and earthing system. Besides, as regards the vacuum inspection system, gas sensors have been installed in hazardous areas, triggering ventilation system when needed, and activating the automatic shut off only after continued leak.

Finally, regarding the refrigerant charging machines, electrical components are separated and encapsulated to avoid contact with the refrigerant. There is an enclosure at the charging area to avoid spreading R290. There is antistatic floor, there are proper earthing connections and there is ventilation in the charging station as well as in the enclosure as well as under the conveyor belt. For refrigerant supply, a dedicated storage area is located outside, next to the building.

Procurement of new equipment

The company made a procurement plan according to the implementation plan. The procurement was finished in March 2013. By July 2013, all equipment has been installed and commissioned by the company.

Product redesign and development

Dimension

Indoor unit: 930x370x298 (mm)

Outdoor unit: 760x285x590



Picture 2. Product redesign.

Configuration

Heat exchanger for indoor unit

Φ7 Inner grooved copper tube, 4 input and 4 output. The main purpose of the heat exchanger modification is to reduce the charge size, and it is related to the reduction of the tube diameter. This reduced diameter may have a positive impact on the heat transfer coefficient.

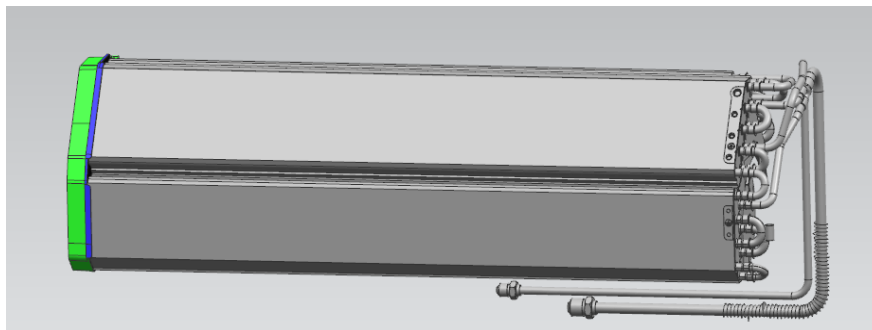

Picture 3. Configuration

Condenser

Φ5 Inner grooved copper tube, 5 input and 5 output. In this case, the condenser has been changed from the former 9 mm tube to reduce the charged refrigerant mass.

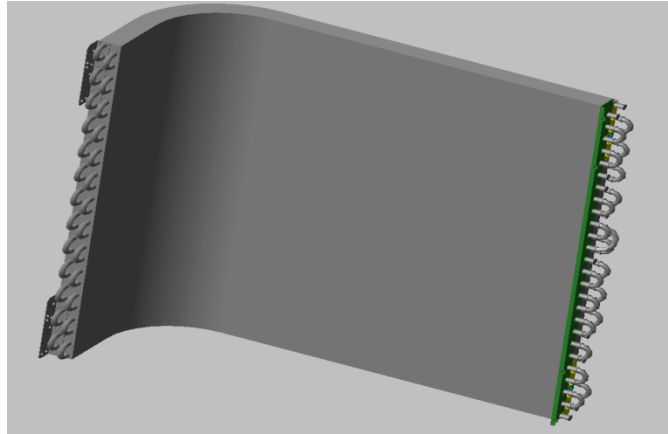

Picture 4. Condenser

Compressor

Type: DD180G1C-10DZ

Discharge rate: 18.0 cm³/rev. Changed from 13.0 cm³/rev.

Fan

Indoor: WZDK30-38G output: 30W

Outdoor: WZDK35-38G output: 35W

There has been no conversion in this case.

Safety measures

The terminal block of outdoor unit

A new outdoor unit structure was designed to prevent accumulation of leaked refrigerants. In addition, as an initial approach, gas detectors were fixed near the most potential ignition sources (electrical connections) to detect and alarm if there is any refrigerant leakage.

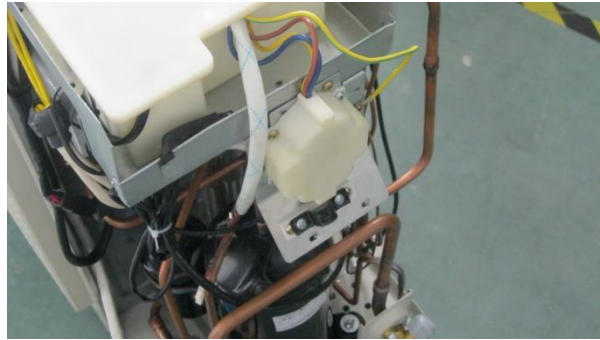
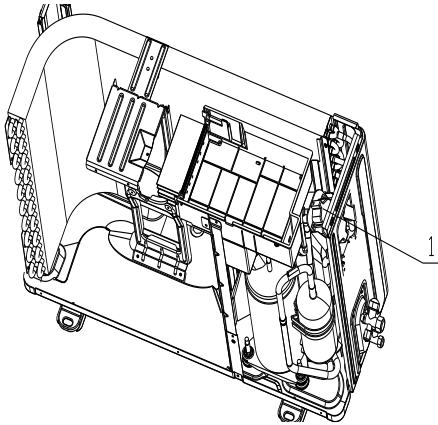

Picture 5. Outdoor units

However, the manufacturers are currently focusing more on the elimination of the ignition source rather than installing such sensors. In order to avoid ignition, electrical parts are encapsulated, the end of the heat exchanger is covered, the cabinet is designed for natural ventilation, etc. It is an ongoing process to be refined with the experience gained, nevertheless, installation of the detectors on the outdoor unit will most likely not be a future feature of smaller units.

Leak detection

Gas detectors were added for both indoor and outdoor unit. When gas leak were detected the electrical control component will switch off the machine.

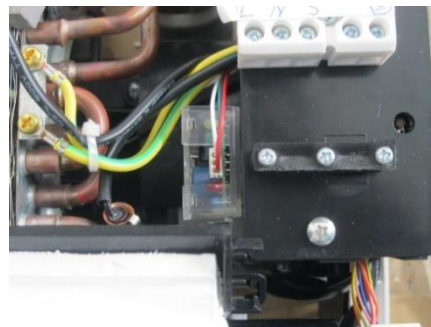

Picture 6. Leak detection

Auto lock designing

Solenoid valves were placed on the tubes of outdoor unit. The leak control and testing is improved to reduce the overall leak rate.



Picture 7. Auto lock

Safety design to process pipes

Locking connector was used for pipes. When refrigerant is charged, it is sealed flameless.



Picture 8. Safety design to process pipes

Prevent gas concentration

Clapboard with special structure was designed between the fan blades and compressor of the outdoor unit. It will help air flow in the space between compressor, the pipe and electrical devices.

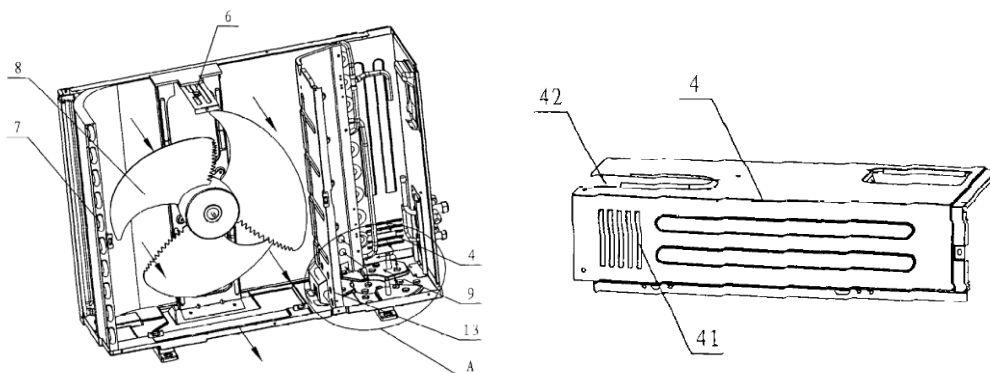

Picture 9. Special clapboard

Destruction of HCFC-22 equipment

In November 2013, Midea destroyed its HCFC-22 equipment from the converted production line. The company invited Shunde EPB to witness the disposal.

Training

Midea has organized several training workshops focused on different topics and trainees:

Table 3. Training workshops – Midea

	Trainer	Topics	Trainee	Place	Number of participants	Date
1	Daniel Colbourne	International standards	R&D engineers	Shunde	15	July 2012
2	Liu Xu	Structure of R-290 A/C and its characteristics	Process engineers	Shunde	30	October 2012
3	Li Tingxun	Selection of alternative refrigerants	R&D engineers	Shunde	100	June 2013
4	Liu Zhen	Safety protection of R-290 A/C	Maintenance engineers	Shunde	120	March 2014
5	Zhou Xiangyang	A/C with flammable refrigerants	Process engineers	Wuhan	30	Mai 2014
6	Li Tingxun	Standards for flammable refrigerants	R&D engineers	Shunde	100	June 2014

Furthermore, experience gained by Midea has been and is being disseminated at various national and international conferences and workshops:

- During network meetings;
- At the annual international conference of RAC manufacturers in China, which is held end October/early November;
- At the Atmosphere Europe event that was held in June 2013 in Vienna;
- During conferences on HCFC alternatives in high ambient conditions;
- Through UNEP webinars.

3.2.1 Meizhi

After 30 months implementation, the conversion project was completed by the end of 2013; all equipment and lab facilities were installed and tested. One prototype was sent to be tested at China Testing & Inspection Institute for Household Electric Appliances. The report shows that all required

parameters can meet national standards. The production line is ready for final commission, which is planned for November 2014³.

The following activities were carried out in the implementation: product redesign, procurement of necessary equipment and systems, modification of tools and parts, installation, debugging and trial of production lines, training, pilot production and performance testing of R-290 compressor as well as technology dissemination.

Product redesign

Three types of compressor were designed, including both fixed frequency and variable frequency. The specifications of compressors are as below:



Table 4. Types of compressors



Type	Power	Capacity (w)	HP(w)*	COP (w/w)*		
				R-290	HCFC-22 ¹	Minimum requirements
DSK118D10UBZ	DC INV	1700	515	3.3	---	---
DSN180V1UDZ	220/240V/50Hz	2700	820	3.29	---	---
DSM180V1UDZ	220/240V/50Hz	2700	830	3.25	3.15	3.10



1. There are no basic R-22 models of DSK118D and DSN180V, these two models were specially designed for R-290. The DSM180V is developed based on R-22 model HSM180V, but the motor of DSM and HSM is different, so the result is only for reference.

Other design changes are described and illustrated on the series of pictures of the various main parts affected.

³ The other two prototypes will apply also the certification and the schedule depends on the market demand.

CVI INDEX		<p>Change of: Inner Diameter, Height, Position of bolt holes,</p>
MAIN		<p>Change of: Inner Diameter, Height, Position of bolt holes,</p>

SUB		<p>Change of: Inner diameter,</p>
ROLLER		<p>Change of: Inner and outer</p>
PLATE		<p>Change of: Height</p>

CRANK		<p>Change of: Outer diameter</p>
STATOR		<p>Change of: Inner and outer diameters.</p>

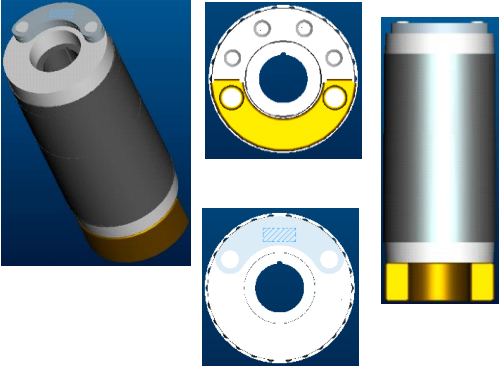
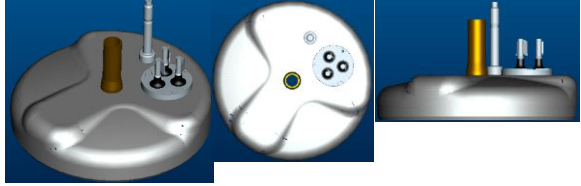
<p>ROTOR</p>		<p>Change of: inner and outer diameters, shape of lamination, shape of balancer</p>
<p>UPPER CASE</p>		<p>Change of: outer diameter</p>

Picture 10. Design changes on different compressor's parts.

The conversion of the compressor was done with the following two objectives:

- a) To increase compressor swept volume to offset the slightly reduced capacity of R-290, which has also an impact on the electromotor.
- b) To optimize the compressor in order to minimize the refrigerant contained in the oil. As a result of this effort, the compressor contributed to approximately 5% charge reduction in the RAC unit and the oil quantity was also reduced.

Lubricant selection

Besides the reduction of the charge size, one of the main challenges in the manufacturing of these appliances was the development of a suitable lubricant^{4 5}.

Regarding the technical aspects of oil selection, besides the basic property called for lubricant oil, the other three key points are solubility, miscibility and viscosity.

Since R-290 has very good solubility with almost all kinds of oil, the manufacturer considers that the lowest the solubility and the miscibility, the better.

⁴ Due to the changed performance of the lubricant, the anti-wear treatment of some of the components of the compressor was modified. In this sense, for example, the wear of vane tip was too large after compressor left test, and this problem was solved by increase the hardness of the vane tip like use the treatment CrN or DLC coating.

⁵ The supply of raw material, on the contrary, is not a challenge for the development of a suitable lubricant, since compressors manufacturers in China are working together with lubricant suppliers.

On the other hand, the very good solubility also causes the decrease of working viscosity, so it is necessary to test this working viscosity with the viscometer while the compressor is in operation.

Several companies have already made some publications on how to test oil working viscosity in compressors with a viscometer and, besides, this method can be found in the handbook of the viscometer device. Basically, it is necessary to assemble the viscometer on the compressor and run the compressor by using the test device. The working viscosity data can be read on the viscometer screen.

For the analysis of results, it is convenient to make a comparison with a baseline at the same running conditions. This baseline can be set as R-22 compressor with its oil.

However, it is to be noted that each manufacturer has its own developed compressors with components of different sizes, and this can lead to different procedures in lubricant selection.

Conversion of production line

The conversion involves 12 major parts of the production line: assembly, cylinder, roller, bearing, crankshaft, blade, sorting, upper-case, main-vessel, motor coiling, stator/rotor, inspection-tools. The activities mainly include procurement of new equipment, modification and tools and parts.

Procurement of new equipment

There are two fundamental requirements for the equipment: the performance testing equipment should be explosion-proof due to the flammability of R-290; the lubricant chargers, lubricant purifying and supply systems need to be replaced.

Equipment conversion and purchase are described as follows:

Table 5. Equipment conversion and purchase

NO.	Category	Action	Name of line	Contents
1	Production equipment	Modification	Assembly Line	fixture and tools of Cylinder centering machine
2			Cylinder Line	fixture and tools of Automatic chamfering machine
3			Rollor Line	fixture and tools of Automatic internal honing machin
4			Bearing Line	fixture and tools of Automatic internal honing machine
5			Crank Shaft Line	fixture and tools of Semi-Automatic cylindrical grinder
6			Blade Line	fixture and tools of Automatic high-speed surface honing machine
7			Sorting Line	fixture and tools of Blade Sorting Equipment

NO.	Category	Action	Name of line	Contents
8			Case Line	fixture and tools of Blade Sorting Equipment
9			Motor Coiling Line	fixture and tools of Auto rolling machine
10			Stator Varnish Equipment	varnishing tooling
11			high speed press machine	Die & control system
12			Testing tools	Testing tools
1			Performance testing equipment	Purchase
2	Life test Unit for 10 pieces	Life test Unit		
3	Gas Load Test Unit	Gas Load Test Unit		
4	Gas concentration alarm system	Gas concentration alarm system		
5	Lubricant viscometer	Lubricant viscometer		

Modification of tools and parts

The processing and machining equipment can still be used after conversion, but it was necessary to change the tools and moulds to meet the size of the parts for R-290 compressors. Meizhi designed and manufactured these tools and moulds by themselves.

Installation, debugging and trial of the production line

The equipment was delivered and installed in April and May 2012.

Training and technology dissemination

Meizhi has organized three training workshops focused on different topics and trainees:

- 6 March 2011, test operation of R-290 compressors
- 13 January 2012, designing of R-290 compressors
- 10 May 2012, HC refrigerants and its applications

The company has utilized the opportunity of meetings and exhibition to disseminate the R-290 technology. The main activities include:

- The 23rd IIR international Congress of Refrigeration: Refrigeration for Sustainable Development.
- Advancing Ozone and Climate Protection Technologies: Next Steps.

- The 2nd Regional Symposium on Alternative Refrigeration or Air-conditioning Industry in High-Ambient Temperature Countries, the Way Forward 2012.
- Chillventa
- ACREX

4. Results

The results of these two projects can be divided in three different aspects: the environmental impact of the projects, the quality of the new products and the capacity of converted production lines.

4.1. Environmental impact

The implementation of these projects will indirectly benefit the ozone layer by enabling domestic room air conditioner manufacturers to build appliances using refrigerant with no ozone depleting impact. This will prevent the release of refrigerants at two stages: during the life time of the products and at the time of discarding those products.

In this sense, considering the fact that average RAC units traditionally contain 1.2 kg of HCFC-22 refrigerant with an ODP of 0.055, the new compressors manufactured by Meizhi will indirectly phase out 2,196 metric tons of HCFC-22 with a total impact of 121 ODP tons per year, while Midea's new RAC appliances will allow the phase-out of 240 metric tons per year, equivalent to 13.2 ODP tons per year.

The use of these new products will also reduce the emission of Green House Gases (GHG) during the life time of the appliances and in the process of disposal, due to the very low GWP of R-290. The estimated greenhouse gas emission reduction in the Meizhi project is 8,852,533 MT CO₂ equivalent per year of operation of the line at the given capacity. In the case of Midea, this reduction is estimated in 967,490 MT CO₂ equivalent per year of operation of the line at the given capacity.

In addition, in view of the higher energy efficiency of the refrigerant, an indirect reduction of GHG emissions linked to energy consumption is also expected.

Table 6. Environmental impact of the projects*

Projects	ODS		GHG (MT CO ₂ eq.)
	Metric tons of HCFC-22	ODP tons	
Midea	240	13.2	967,490
Meizhi	2,196	121	8,852,533

* Per year of manufacturing on the lines at the given capacity

4.2. Quality of the new products

As mentioned before regarding Meizhi's project, two types of R-290 compressors (fixed and variable frequency) with 1 HP and COP of 4.12-4.33 are available for mass production⁶. The compressors have been tested under the following test conditions:

Table 7. Test conditions

Parameters	Temperature (deg C)
Condensing Temp.	54.4
Evaporation Temp.	7.2
Superheat	10.8
Subcooling	8.3

Tested by Midea under standard GB/T7725-2004.

The energy efficiency ratio of the R-290 compressor is 2%-3% higher than a HCFC-22 compressor⁷. In order to obtain such improvements in the new products' performance, as well as in the system optimization, additional efforts were required in terms of co-financing by Meizhi. This was also the case for Midea's project.

As above mentioned, the certification authorities have already certified the consistency of new air-conditioners with the standard GB 4706.32 (see section 7. Practical findings), which allows the use of flammable refrigerants in RAC products in the local market (3C certificate).

Compliance with international standards has also been certified (IEC/CB and CE).

The types and models of R-290 RAC units that has been developed by Midea is shown in the table below:

⁶ The actual COP is higher than the designed COP parameter (from 3.25 to 3.30), since the new compressor is a DC INV model and the one before conversion was a fix speed compressor. In this sense, the test conditions are different and hence the results are also different.

⁷ The energy efficiency of new compressors was tested with Calorie meter at Meizhi laboratory.

Table 8. Performance information for R-290 based air-conditioners*

Type	Model	Capacity (w)	R-290		HFC-410A		Minimum requirements	Certification
			Charge (g)	COP (w/w)	Charge (g)	COP (w/w)	COP (w/w)	
Split/VF	KFR-26GW/BP3DN7Y	2600	270	4.77(APF)	980(R410A)	4.75(APF)	3.5	CCC
Split/VF	KFR-35GW/BP3DN7Y	3500	360	4.73(APF)	1130(R410A)	4.75(APF)	3.5	CCC
Split/VF	MS11M-09HRFN7-QRC4	2600	310	4.0(SCOP)	1030(R410A)	4.0(SCOP)	3.3(GWP<150)	CB/CE
Split/VF	MS11M-12HRFN7-QRC4	3500	350	4.0(SCOP)	1300	4.0(SCOP)	3.3(GWP<150)	CB/CE
Portable A/C	MPPD-09ERN7-QB6G1	2600	210	3.1	430(R410A)	2.6(R410A)	2.6	CB/CE
Portable A/C	MPPD-11ERN7-QB6G1	3200	230	3.0	520(R410A)	2.6(R410A)	2.6	CB/CE

* The R290 products were developed based on R410A models, thus, there are no comparison data with R22. In addition, R290's RAC efficiency is normally 5-12% higher than R22. Charge mass is only 45% of R22.

In terms of energy efficiency, as shown in the table, the new units can reach the highest standards. Compare to the HCFC-22 based units, the use of R-290 in the new air-conditioners leads to a reduction of 5% to 12% in energy consumption⁸. According to the test result, based on tests undertaken by Midea, in order to achieve the best performance, the 450g refrigerant would be required for a 3,500W capacity (COP = 3.0) split unit, however, the standards allow maximum 350g with which the capacity is less than 3,400W and a COP of 2.8.

Further efficiency improvement both in compressors and AC units could be achieved if the charge sizes specified in international standards were relaxed, since there is a relationship between charge and efficiency, and hence also an optimal charge. Until then, efficiency improvement is mainly dependent on the actual R&D - invested in the product in the past several years and the years to come - that was not financed by the project, and also on system optimization, which was required as in most refrigeration conversion activities in the past. Furthermore, given these restrictions on charge sizes, only a change of refrigerant would have resulted in poorer performance compared to the R22 units, not to mention safety concerns. All products under the demo projects were designed for T1 ambient conditions. After the completion of the project, Meizhi has developed T3 compressors for high ambient regions as well. Capacity of production lines

⁸ The energy efficiency of new AC units was tested at Midea laboratories.

The capacity of the production lines remains the same as before the conversion in both companies: 200,000 units, in the case of Midea, and 1,830,000 units, in Meizhi's production line.

With regard to the latter, more than 20,000 R-290 compressors were produced by the end of 2013, being most of them sold to other AC manufacturers different from Midea.

5. Incremental costs

5.1. Incremental capital costs

In both projects there have been some adjustments regarding the cost of equipment and tools purchased. The following is a summary of these adjustments. Besides, in annexes 1 and 2, a breakdown of these costs is presented, including explanations of the major variations from the original budget.

5.1.1. Midea

The actual cost of the combined pre-charging H₂/N₂ pressure- and leak test was US\$ 74,444 compared to the approved budget of US\$ 32,000. The cost of the ex-proof R-290 storage room was US\$ 59,841, whereas the approved budget was US\$ 32,961. The cost of R-290 storage tank and pipeline including installation amounted to US\$ 132,698 compared to an approved budget of USD 64,039.

Additional items were required, which were originally not budgeted: a booster pump that ensures that the inlet of the charging machine is fed with sub-cooled refrigerant, Nitto quick couplings to avoid leaks during charging and in particular testing, as well as variable frequency power supply to facilitate 110V and 220V as required by different A5 markets. These additional items had additional costs of US\$ 60,000.

Cost of the heat exchanger conversion was 3 times higher than the approved budget, however, it needs to be considered that funding was provided only for 60% of the estimated conversion costs, since the production capacity of the HE was about 330,000 unit per year (before and after conversion), while the converted production line had a capacity of only 200,000.

Cost of other items was similar to the approved budget with differences of up to +/-20%. In this sense, the cost of the equipment purchased amounts to US\$ 3,938,004, out of which US\$ 2,383,967 has been covered by the funds provided by the MLF in line with the approved project based on the eligible A5 ownership.

5.1.2. Meizhi

The actual costs in the case of Meizhi amounted to US\$ 3,398,093 and were about 11% higher than the total agreed project budget (US\$ 3,049,190). However, in these costs, investments related to R&D of the past years have not been included, which is also of significant value. High level of co-financing was required from the enterprise to cover the costs related to the 40% A2 ownership as well as the additional

investments. In this sense, the funds provided by the MLF amounted to US\$ 1,875,000, in line with the approved project based on the eligible A5 ownership.

With respect to the various components, it can be concluded that costs related to the motor coiling line and the rotor & stator line were significantly underestimated in the project document, since these parts are crucial to the performance of the compressors and thus, high quality equipment is required⁹. Conversion of these two lines alone had a cost of US\$ 1,416,187. Actual cost of the conversion of assembly line was about 30% more expensive than approved. Cost of the lubricant viscosity meter was US\$ 31,746 compared to the approved budget of US\$ 11,644. It is to be noted that selection of a suitable lubricant is essential in the reduction of the charge size.

On the other hand, investment costs related to the case line were significantly lower, since a majority of these operations have been outsourced by the company. However, it adds operating cost to the company, which is not eligible for funding. The cost of test tools was also much lower (about 20% of the approved budget) and savings could be made on the purchase of the gas concentration alarm system (1/3 of the approved budget) due to the fact that these tools were sourced domestically instead of the originally foreseen imported equipment. The cost of other items was similar to the approved budget with differences of up to +/-20%.

5.2. Incremental operating costs

IOC for compressor for Midea was not covered by the funds provided by the MLF, instead the conversion of Meizhi compressor manufacturing line was financed. The cost of the new compressor manufactured by Meizhi is US\$ 7.57 higher than the HCFC-22 based compressor.

In the case of Midea, the estimated IOC for one split unit is currently US\$ 41.95, as described in the table below.

Although the actual IOC is significantly higher than the eligible USD 6.3/kg, these additional costs are associated with the product initiation and expected to decrease in future, albeit not quite the level of the IOC threshold. In addition, the methodology for applying the safety measures is also being refined. UNIDO will continue to monitor the progress of the IOC as part of the RAC sector plan.

⁹ The high cost of these lines was due to the high quality equipment that was required in order to fulfil the technical requirements of conversion. There was no other option for conversion and, thus, there is no difference between the cost increases resulted from performance upgrade and those from conversion.

Table 9. Incremental operating costs - Midea

Item	Incremental cost/RMB	Incremental Cost/USD	Remarks
Heat exchanger	-31.05	-5.09	40 meters of copper tube for condenser, with 7.395 RMB per meter of 7 mm and 6.61875 RMB per meter of 5mm
Refrigerant	-3.02	-0.50	1.2 kg HCFC-22 with 10.126 RMB/kg, 0.3kg R-290 with 30.45 RMB/kg
Lokring	10	1.64	One lokring costs 2.5 RMB and there is a need for four
Compressor	46.19	7.57	Data from Meizhi
Electronic parts	99.63	16.33	Electronic parts are sealed
Labor cost per unit	4.14	0.68	Based on 0.006RMB/second;
Installation	130	21.31	Installation of one HCFC-22 unit requires 4,440 seconds and an R-290 one needs 6,690 seconds, with a labor cost of 0.052 RMB/sec.
Total	255.89	41.95	

In this project, 50% of the IOC relates to additional labor costs due to the necessary safety features applied to the product.

6. Safety issues

As above mentioned, contrary to HCFC-22, R-290 is flammable and explosive refrigerant and therefore, significant changes should be introduced to the existing design and use of air-conditioners and compressors.

In the case of RAC units manufactured by Midea, these changes are introduced to reduce the amount of the refrigerant in the appliance, control refrigerant containment and prevent large leakages. Furthermore, safety measures need to be adopted in every step including production, storage, transportation, as well as installation and servicing of the appliances at the costumers.

In light of the above, to reduce hazards in the manufacturing of RAC units the following major principles are followed during the product and technology conversion:

- a. The charge size of R-290 A/C should be dramatically reduced comparing to HCFC-22. In view of the excellent thermo-physical performance of R-290, especially its large latent heat and favorable viscosity, the charge amount of R-290 refrigerants can be substantially lowered without compromising on the cooling capacity of the A/C;
- b. The new split units should be equipped with explosion proof components, leak sensor and a special sensor, which monitors the temperature/pressure ratio to recognize eventual refrigerant leaks and avoid formulation of hazardous air/refrigerant mixture within the room being cooled;

- c. In the manufacturing, repair and testing processes gas detection, monitoring and safety ventilation systems as well as emergency power supply should be installed. The hazardous areas should be thoroughly checked and safety risks should be eliminated, e.g. all equipment in the hazardous areas should be made Ex-proof and properly grounded to eliminate risks arising from sparks in case of a potential leakage of refrigerant, the plant floor in the hazardous areas should be painted with antistatic coating for the very same reason.
- d. The manufacturing, plant maintenance as well as the appliance installation and service personnel should be thoroughly trained.
- e. Special tools are to be provided to the service staff for the installation of R-290 RACs.

Developments continue post-project with the aim to minimize and simplify product modifications while maintaining safety, in order to expand the range of products. In this sense, there are efforts on simplifying the safety measures - like the one mentioned on the sensor for the outdoor unit – and, furthermore, significant efforts are being made to reduce charge size without significantly compromising the system performance, as well as extending the application to larger units.

Concerning the production of compressors, the main safety measures to be considered are as follows:

- a. Electric components inside the R-290-based compressor should be sealed. This results in the modifications of the electric components and structure of the compressor;
- b. Flammability of the new refrigerant requires special explosion-proof performance testing machines, such as calorimeter, life test units, gas load testing unit and operation testing unit for the compressor.

Besides these principles, relevant foreign standards and practices for the production of R-290-based room air-conditioners and compressors can be a reference to Chinese manufacturers.

In conjunction with RAC sector plan, FECO has cooperated with Tianjin Firefighting Research Institute to design and conduct a research on the flammability of R-290 refrigerant in a common use scenario. Air-conditioners were installed in rooms of various sizes and refrigerant leaks and burning were tested in different conditions. The experiment report was made available in May 2013 and published in English on *International Journal of Refrigeration*. The experiments and assessments showed that the possibility of fire and explosion for a wall-mounted R-290 air-conditioner is 10^{-8} - 10^{-9} per year under household use conditions, which is 1/10 of the risk of a domestic refrigerator with hydrocarbon. In June, an expert panel discussed and determined the key points of next phase's risk assessment, including risks in the servicing and installation processes, risks at different charges, and secondary risks from a fire.

7. Practical findings/Lessons learnt

With regard to the project, the main point to highlight is that its approval and implementation were essential for the development of R-290 units, and have also been a basis for the RAC phase-out strategy

in China. As a result, by now, most RAC manufacturers in the country are involved in R-290 conversion activities and R&D.

In terms of market introduction, since the local market is so relevant for both companies, the following lessons can be learnt:

- Due to the introduction of new alternative technologies in the RAC sector, modification on the existing Chinese standards as well as establishment of new standards will be a key factor for the adoption of alternative technologies.
- Technology promotion is essential for the introduction of R-290 in the local market. New policy/financial measures should be considered to help the R-290 air-conditioners' sales in the market.
- Training on the servicing and installation of the RACs with flammable refrigerants is prerequisite for the market introduction and safe use of the R-290 air-conditioners.

Regarding the standards, FECO has cooperated with the China Household Electrical Appliances Association (CHEAA) to establish 3 standards for flammable refrigerants. These are technical safety codes for using flammable refrigerants in the household and similar air-conditioners manufacturing industry, the particular requirements for transportation of room air-conditioners charged with flammable refrigerants, and technical safety codes for servicing. The draft standards are planned to be prepared in 2014, while the adoption of the standards is envisaged in 2015.

In parallel, on 1st May 2013, the standard GB4706.32 on Safety of Household and Similar Electrical Appliances – Particular Requirements for Heat Pumps, Air-Conditioner and Dehumidifier, came into effect. The standard is equivalent to IEC 60335-2-40, which allows application of flammable refrigerants in air-conditioner systems provided that they meet the specific requirements such as charging amount, labelling and electric safety measures.

Concerning the market introduction, FECO, in partnership with an association of manufacturers, has established a market promotion subsidy scheme by which those manufacturers that sell R-290 AC units in 2014 and 2015 can get a subsidy up to a level of US\$50 for the first 10,000 units they produce. In 2016, this subsidy will be half of the above mentioned amount.

Besides this, since 2008 many initiatives have been launched to control and limit the production, commercialization and consumption of ODS as the HCFC refrigerants. Among these initiatives, it can be mentioned the *Circular on the Catalogue of Controlled ODS in Import & Export (5th batch)*, the *Circular on Strict Control over the Establishment of Facilities Using HCFCs* and the *Circular on Strict Control of HCFC Production Facilities*. In June 2010 it entered into force the *Regulation on ODS Management*, which was reviewed and approved in principle at the Executive Meeting of the State Council chaired by Premier Wen Jiabao. More recently, in August 2013, the MEP issued the *Notice on quota permit for the production, sale and consumption of HCFCs*. These initiatives establish a legal

framework to reduce the use of ODS and, therefore, they promote indirectly the adoption of alternative refrigerants, as for example the R-290 that has been tested in these projects.

Finally, with respect to the training on the servicing sector, a feasibility study on the certification of servicing workers has been initiated by FECO to standardize the operation of servicing workers and minimize the unwanted emission and discharge of refrigerant.

8. Conclusions

- R-290 is an environmentally friendly refrigerant, since its ODP is zero and its GWP is as low as three. With an excellent cooling performance, R-290 is considered one of the ideal alternatives of HCFC-22 in the RAC sector after conversion of production lines.
- R-290 is available in the Chinese market.
- The conversion of two of the most important production lines of RAC units and compressors in China has maintained the quality and performance of the appliances produced by these two companies. Their performance is consistent with national (CCC) and international standards (IEC/CB and CE), and this has already been certified by the authorities.
- In order to obtain such improvements in the new products' performance, as well as in the system optimization, significant additional efforts were required in terms of co-financing by both companies.
- Regarding the new compressors' performance, the energy efficiency is 2%-3% higher than HCFC-22 compressors.
- Concerning the new RAC units' performance, the energy efficiency is 5%-12% higher than HCFC-22 air-conditioners.
- Further efficiency improvement both in compressors and AC units could be achieved if the charge sizes specified in international standards were relaxed, since there is a relationship between charge and efficiency. Until then, efficiency improvement is mainly dependent on the actual R&D - invested in the product in the past several years and the years to come - and also on system optimization, which was required as in most refrigeration conversion activities in the past.
- **Two types of R-290 compressors (fixed and variable frequency) with 1 HP and COP of 4.12-4.33** are available for mass production after the conversion of the production line.
- **Two types of R-290 RAC units (split/VF and portable A/C) and six different models** are also available for mass production after conversion.

- The conversion of production lines and the manufacturing of new appliances can be handled safely, despite the flammability of R-290, if appropriate measures are implemented and appropriate tools and equipment are used.
- Developments continue post-project with the aim to minimize and simplify product modifications while maintaining safety; as well as to reduce the refrigerant charge in order to expand the range of products.
- The experiments and assessments show that the possibility of fire and explosion for a wall-mounted R-290 air-conditioner is only 10^{-8} - 10^{-9} per year under household use conditions in China. Nevertheless, the next stages of phase-out programme should focus on risks in the servicing and installation processes, risks at different charges, and secondary risks from a fire.
- Besides, in order to foster the introduction of this new technology in the Chinese market it is necessary to establish new policies and financial measures, as well as updated safety standards.

Incremental capital costs

- In the case of both Midea and Meizhi, the projects have had higher capital costs than the agreed project budget.

Incremental operating costs

- Regarding Midea's project, the estimated IOC for one split unit is currently US\$ 41.95. Although the actual IOC is significantly higher than the eligible USD 6.3/kg, these additional costs are associated with the product initiation and expected to decrease in future, albeit not quite the level of the IOC threshold. In addition, the methodology for applying the safety measures is also being refined.
- The cost of the new compressor manufactured by Meizhi is US\$ 7.57 higher than the HCFC-22 based compressor (cost already part of the above calculation). IOC for compressor for Midea was not covered by the funds provided by the MLF, instead the conversion of Meizhi compressor manufacturing line was financed.

The approval and implementation of these demonstration projects was key for the development of R290 units and was a basis for the RAC phase-out strategy in China. As a result, by now, most RAC manufacturers in China are involved in R290 conversion activities and R&D.

While these demonstration projects in China were successful, the application of hydrocarbon (HC) technology should be carefully evaluated in context of the local situation prevailing in each country. The report by no means concludes that the technology was sufficiently consolidated to be applied in all countries, and did not address issues of availability and cost in the field. Finally, interested parties must take into consideration the proprietary issues related to the technology.

ANNEX 1. Cost of equipment purchased - Midea

No.	Area	Conversion or Procurement	Equipment	Conversion details	Budget (USD)	Budget (USD)	Actual cost (USD)	MLF financing (USD)	Company co-financing (USD)	Remark	Additional remarks
1	Assembly Line Equipment	Conversion	Assembly Line	Assembly line relocation	117,000	117,000	227,302	140,400	86,902	Combined with Item 2 and item 16	The beneficiary has installed a new line, instead of converting the original one. This was the main reason for the higher costs. 20% beyond the budget was compensated in line with existing MLF rules.
2				Antistatic floor and ground circuit in the hazardous areas						Combined with Item 1 and item 16	
3				Power distribution explosion-proof modification for the production line						Combined with Item 1 and item 16	
			variable frequency power supply	Included above							
				Nitto quick coupling for the products	Additional items purchased that were required. 275 units of quick couplings were purchased for charging to avoid leakage. Frequency power supply was required since various countries have various needs and the tests have to be made accordingly						

No.	Area	Conversion or Procurement	Equipment	Conversion details	Budget (USD)	Budget (USD)	Actual cost (USD)	MLF financing (USD)	Company co-financing (USD)	Remark	Additional remarks
4		Conversion	Function Test system	Function test units adjusted to the properties of R-290 (including Electrical safety tester and new quick connectors)	85,000	85,000	99,365	85,000	14,365	Combined with item 5, item 12 and item 30; 30test units	difference less than 20%
										30 test units	
6		Procurement	Refrigerant Charging	New refrigerant charging machines (including the transportation pump in the storage room)	100,000	320,000	352,143	320,000	32,143	Combined with item 15, item 17 and item 33	difference less than 20%
15			Leak detectors	Gas detection (IR) (included in the safety system)	-					Combined with item 6, item 17 and item 33	
16			Ventilation system	Safety ventilation system for R-290-based RAC production line	80,000					Combined with item 1 and item 2	
17	Safety System		Safety alarm system for R-	140,000	Combined with item 6, item 15 and item 33						

No.	Area	Conversion or Procurement	Equipment	Conversion details	Budget (USD)	Budget (USD)	Actual cost (USD)	MLF financing (USD)	Company co-financing (USD)	Remark	Additional remarks
				290-based RAC production line and R290 storage room							
7				Ex-proof R290 storage room	32,961	32,961	59,841	32,961	26,880		
8		Procurement	Refrigerant Supply equipments and pipeline	New storage tank for R-290 and New R290 pipeline installation for the production line and R290 storage room	64,039	64,039	132,698	76,847	55,851	Combined with item 9	The beneficiary installed a bigger storage room than required for the one line in order to cater for the needs of additional R290 lines in future. 20% beyond the budget was compensated in line with existing MLF rules.
10		Procurement	Vacuum system and vacuum test	Ex-proof vacuum pumps	-	-	88,198	-	88,198	Combined with item 11	not eligible item
11	Vacuum meter			Combined with item 10							
12	Conversion			Vacuum measuring system modification						Combined with item 4, item 5 and item 30	
13		Conversion	Helium leak testing system		32,000	32,000	74,444	38,400	36,044		The budget approved was not sufficient and in future higher cost should be approved for a He leak testing system. 20% beyond the budget was compensated in line with existing MLF rules.

No.	Area	Conversion or Procurement	Equipment	Conversion details	Budget (USD)	Budget (USD)	Actual cost (USD)	MLF financing (USD)	Company co-financing (USD)	Remark	Additional remarks
14		Procurement	Leak detectors	New portable R290 detectors for production line/test room/storage and new Helium leak detector for heat exchanger	80,000	80,000	83,200	80,000	3,200		difference less than 20%
18		Procurement	Sealing machine	LOKRING sealing machine	60,000	60,000	11,762	11,762	-		
19	Heat Exchanger Process Equipment	Conversion	High-speed fin stamping Press	Conversion of various parts of the high speed fin press and its stacker, fixtures and parts	103,700	417,850	1,646,337	459,635	1,186,702	Combined with item 20	The production capacity of the heat exchanger was about 330,000 unit per year (before and after conversion), while the converted production line had a capacity of only 200,000. For this reason, the approved budget was reduced according to the line capacity. However, the conversion of the heat exchanger producing equipment had to be done for the original full capacity (330,000 units) and thus, costs were consequently higher.
20		Procurement		Procurement of moulds for fin press	314,150					Combined with item 19	
21		Conversion	Hair pin tube bending machine	Conversion of the Ø9.52-sized Hair Pin Bending machine to Ø5-sized one, new tools.	24,000	24,000	62,698	24,000	38,698	Combined with item 25	
22			Connection curve bending machine	Conversion of the Ø9.52-sized connection curve bending	12,000	12,000	18,651	12,000	6,651	Combined with item 23 and item 24	

No.	Area	Conversion or Procurement	Equipment	Conversion details	Budget (USD)	Budget (USD)	Actual cost (USD)	MLF financing (USD)	Company co-financing (USD)	Remark	Additional remarks
				machine to Ø5-sized one, new tools.							
23			Cutting machine	Conversion of the Ø9.52-sized cutting machine to Ø5-sized one, new tools.	15,000	15,000	23,810	15,000	8,810	Combined with item 22 and item 24	
24			CNC Tube Bending Machine	Conversion of the Ø9.52-sized CNC tube bending machine to Ø5-sized one, new tools.	16,000	16,000	21,746	16,376	5,370	Combined with item 22 and item 23	
25			Automatic Tube End Processing Machine	Conversion of the Ø9.52-sized automatic tube end processing machine to Ø5-sized ones, new tools.	13,000	13,000	10,397	10,397	-	Combined with item 21	
26			Expander Presses	For small diameter of tube.	198,250					Combined with item 27	
27			Expander Fixtures and Jigs	For small diameter of tube.	134,200	332,450	660,317	332,450	327,867	Combined with item 26	
28		Procurement	Welding Ring Insertion Machine	For small diameter of tube.	20,000	20,000	19,381	19,381	-		

No.	Area	Conversion or Procurement	Equipment	Conversion details	Budget (USD)	Budget (USD)	Actual cost (USD)	MLF financing (USD)	Company co-financing (USD)	Remark	Additional remarks
29			Cleaning Machine	New cleaning machine for Ø5-sized tubes.	18,000	18,000	18,730	18,730	-		
30	Operating performance test equipment	Conversion	Ex-proof conversion	Explosion-proof modification of the function test	20,000	259,000	326,984	284,900	42,084	Combined with item 31 and 32	Actual costs confirm that the original budget was somewhat underestimated. For this reason, 10% beyond the budget was compensated in line with existing MLF rules.
31		Procurement	Capacity test	Capacity test unit suitable for R-290 RAC	159,000					Combined with item 31 and 32	
32			Life test Unit	Life test units suitable for R-290 RAC	80,000					Combined with item 30 and 31	
33	R290 recovery station	Procurement	R290 recovery station	Ex-proof recovery stations for R-290	10,000	10,000	see remarks			Combined with item 15, item 17 and item 6	
34	Tools for Installation	Procurement	Tools for Installation	Refrigerant Bottles	15,750	15,750	see remarks			To be purchased as soon as sales start and will be paid by company co-financing.	Will be additional costs and are required as eligible items
35				Ex-proof vacuum pump	180,000	180,000	see remarks			To be purchased as soon as sales start and will be paid by company co-financing.	Will be additional costs and are required as eligible items
36				LOKRINGS tools	396,000	396,000	see remarks			To be purchased as soon as sales start and will be paid by company co-financing.	Will be additional costs and are required as eligible items

No.	Area	Conversion or Procurement	Equipment	Conversion details	Budget (USD)	Budget (USD)	Actual cost (USD)	MLF financing (USD)	Company co-financing (USD)	Remark	Additional remarks
37	Others	Delivery, insurance, installation of manufacturing equipment etc. 7.5%			189,004	189,004	see remarks	189,004	-189,004	Total cost for this line is not possible to identify due to the many items and purchases made. For this reason, the total approved budget is indicated for this line item and co-financing amount is reduced accordingly.	
38		Contingency			270,905	270,905		216,724	-216,724	Since actual costs were higher than the original budget (including A2 ownership), the co-financing amount was reduced by the approved contingency budget.	
TOTAL					2,979,959	2,979,959	3,938,004	2,383,967	1,554,037	39% of the total equipment cost was company co-financing	

ANNEX 2. Actual costs – Meizhi

Activities	Total Budget US\$	Actual Expenditure (USD)	MLF Actual (USD)	Co-financing (USD)	Remarks
Motor coiling line	131,285	619,048	131,285	487,763	Costs have significantly increased, since higher standard equipment was selected, as these are essential for compressor performance;
ROTOR & STATOR line	397,020	797,139	305,483	491,656	Costs have significantly increased, since higher standard equipment was selected, as these are essential for compressor performance;
Assembly Line	170,217	216,990	170,217	46,773	
CASE line	132,210	3,499	0	3,499	it has been largely outsourced, that is the reason for the under-expenditure
ROLLOR line	79,281	72,393	72,393	0	
MAIN BEARING line	33,814	29,124	29,124	0	
SUB BEARING line	33,814	33,965	33,965	0	
CRANK SHAFT line	79,282	81,892	72,804	9,088	
CYLINDER line	52,854	53,615	52,854	761	
BLADE line	6,607	4,675	4,675	0	
sorting line	11,653	3,425	0	3,425	domestic purchase reduced costs
Test tools	264,268	38,206	0	38,206	domestic purchase reduced costs
Calorie Meter	330,335	373,016	330,335	42,681	

Activities		Total Budget US\$	Actual Expenditure (USD)	MLF Actual (USD)	Co-financing (USD)	Remarks	
Life test Unit		488,896	552,381	488,896	63,485	Another unit will be purchased by the company outside the project budget	
Gas Load Test Unit		158,561	115,714	0	115,714	purchased before the project was approved, so cost was paid as co-financing, but it is in fact and actual ICC	
Gas concentration alarm system		39,000	13,270	13,270	0	domestic purchase reduced costs	
Lubricant viscometer		11,644	31,746	11,644	20,102	The planned viscosity meter did not meet the requirements and for this reason another type had to be purchased	
Sub-total		2,420,741	3,040,098	1,716,945	1,323,153		
Production trials	material cost	42,750	49,495	42,055	7,440	costs related to prototyping	
	Labour Costs	5,750	5,750	0	5,750	cost was covered from company's budget	
	Evaluation and Testing	1,750	1,750	0	1,750	cost was covered from company's budget	
Sub-total		50,250	56,995	42,055	14,940		
Technical Assistance Costs	Design conversion	Redesign of products, production line, manufacturing procedures and conversion of specialized software	100,000	100,000	45,000	55,000	estimated staff costs, company's co-financing

Activities		Total Budget US\$		Actual Expenditure (USD)	MLF Actual (USD)	Co-financing (USD)	Remarks
	Technical communication, survey and consulting	Technical communication with component suppliers, Technical communication with downstream companies, Expert costs	60,000	60,000	30,000	30,000	estimated staff costs, company's co-financing
	Consultant (External coordination and cooperation)	Safety test of compressors Selection of lubricant	100,000	100,000	0	100,000	estimated costs, company's co-financing
	Test and certification	Test and certification of products Component and material tests	25,000	25,000	25,000	0	
Sub-total		285,000	285,000	100,000	185,000		
Training Cost	Training of processing staff		12,000	12,000	12,000		level of additional costs born by the company is not known
	Training of test staff		4,000	4,000	4,000		level of additional costs born by the company is not known
Sub-total		16,000	16,000	16,000	0		
Contingency		277,199	See remarks	See remarks	See remarks		Included in the above items
TOTAL		3,049,190	3,398,093	1,875,000	1,523,093		

Demonstration project for conversion from HCFC-141b-based technology to iso-paraffin and siloxane (KC-6) technology for cleaning in the manufacture of medical devices at Zhejiang Kindly Medical Devices Co. Ltd.

FINAL REPORT

August 2014

Submitted by:

Foreign Economic Cooperation Office, Ministry of Environmental Protection, China (FECO/MEP)

and

United Nations Development Programme (UNDP)

Executive Summary

Demonstration project for conversion from HCFC-141b-based technology to iso-paraffin and siloxane (KC-6) technology for cleaning in the manufacture of medical devices at Zhejiang Kindly Medical Devices Co. Ltd. (KDL) was approved by the 64th Executive Committee meeting at a funding level of US\$557,667 from the Multilateral Fund and \$205,616 as bilateral cooperation from the Government of Japan.

This demonstration project was successfully implemented, and established the suitability of KC-6 technology as a viable replacement for HCFC-141b as solvent and Silicone oil diluent in the manufacture of needles at Zhejiang Kindly Medical Devices Co. Ltd.

The project activities includes product redesign and development, equipment installation and modifications safety and other measures to handle the flammability, laboratory testing and performance evaluation, product trials, biocompatibility and drug-compatibility testing, production line conversion, technical assistance and training.

The successful completion of the demonstration project contributes towards promotion of this technology for medical devices production and enables cost-effective conversions at other similar manufacturers in this sub-sector.

1. Introduction

In 2007, the 19th Meeting of Parties of the Montreal Protocol agreed on accelerated phase-out of HCFCs. To achieve the compliance goal, China is implementing HCFCs phase-out sector plans in the solvent sector from 2012. The KDL project was established as a demonstration earlier in 2010 for preparation and support of the sector plan implementation.

The Executive Committee approved the KDL demonstration project at the 64th meeting in 2011 at a funding level of US \$ 557,667. The project's implementing agency is UNDP. Total approved funding from MLF was US \$ 352,051. Additional funding of US\$ 205,616 has been approved as a bilateral cooperation component with the Government of Japan, with UNDP as the implementing agency. The national agency implementing this project is Foreign Economic Cooperation Office (FECO), Ministry Of Environmental Protection, China.

The objective of this demonstration project is to establish the suitability of KC-6 technology as a viable replacement for HCFC-141b as a solvent in the manufacture of needles at Zhejiang KDL Co. Ltd.

As a result of the conversion project, about 27.82 tons of HCFC consumption has been phased out, reducing greenhouse gas emission by 19,613 tons CO₂ eq. The implementation of the project followed the rules and procedures of National Execution (NEX). The Performance Based Payment (PBP) mechanism was applied for the implementation.

1.1 Background

The major applications of HCFCs within the solvents sector in China include cleaning in the Medical, Metal (Compressors), Metal (Other), Electronics (LCD), Electronics (Precision), Electronics (Other) and Formulated Solvents sub-sectors. According to survey statistics, the HCFC consumption in the Solvents Sector in China was 4,394 metric tonnes HCFC-141b in 2009.

The Medical Cleaning Applications sub-sector is important from a human health perspective and consumed about 1,700 metric tonnes of HCFC-141b in 2009, representing about 39% of the overall solvent sector consumption. The sub-sector manufactures a range of products that are applied widely and involve more than 400 enterprises. Since 1980s, along with China's rapid economic development, the sub-sector has made great progress and

maintained an average annual growth rate of over 15%, and China has, thus, become the world's leading medical macromolecular product manufacturer. According to statistics, in 2009, the gross sales in the sub-sector exceeded US\$ 1.5 billion, 16% higher in real terms than a year earlier. The main products manufactured in this sub-sector include syringes, infusion sets, blood transfusion sets, various puncture instruments (e.g., hypodermic needles, scalp vein sets, blood collection needles, intravenous canulae, puncture needles, biopsy needles, etc.), catheters and other sanitary materials. The devices manufactured are siliconized to reduce friction and the patients' pain; in addition, the silicification tooling used in the manufacturing of these devices needs regular cleaning, so as to prevent the tooling stained with silicone oil from polluting the joints of puncture instruments. The sub-sector comprises a large number of SMEs with limited access to alternative technologies for HCFCs and their viability depends upon accessing suitable alternative technologies at the earliest. For these reasons, China has prioritized this sector and sub-sector for early interventions to meet the 2013/2015 targets.

To work out a cost-effective and sustainable alternatives to HCFC-141b technology that could be implemented in the large number of predominantly SMEs in the Medical Cleaning Applications sub-sector, the Solvent Demonstration project was prepared and submitted for the consideration at the 64th Meeting of the Executive Committee after due review and endorsement by the Government.

1.2 Silicification and its tooling cleaning process with HCFC-141b

Puncture instruments, such as medical needles, need to be coated with a layer of silicone oil on the blade and the tube. This process is called silicification. The purpose of silicification is to reduce frictional resistance and the patients' pain when the needle pierces the skin. This process is completed at the silicification working station of assembly machines.

Silicification tooling refers to a special kind of working station utensil (see pic1) that is used on the assembly machines for puncture instruments. Needle assembly and silicification must be completed on this tooling. Each strip-shaped tooling contains 50 steel needle seats with unfinished needles. Each needle assembly machine usually has at least 600 such tooling. When the needles are siliconized, the tooling is contaminated by silicone oil, so it is necessary to clean the tooling on a regular basis. Otherwise, the silicone oil will stick on the inner bore of needle hubs and the outer surface. Accordingly, when needles are put on syringes, they will fall off automatically or the connection may not be secure. In case of continuous production, each tooling needs cleaning every 15-20 days.

The original single-tank open-type ultrasonic cleaning machines are located in KDL's Class 100,000 clean room which was built in May 2005. Each cleaner could clean about 200,000 stripe-times of silicification tooling every year; in 2009, the consumption of KC-3000C¹ was about 33.6 tonnes (equivalent to 21.84 metric tonnes of HCFC-141b). The machines in current use are all single-cylinder ultrasonic cleaners. Workers are needed to load and unload the materials. After cleaning, the materials have to be put on the shelf for drying. There are mainly 4 processes, i.e. loading, cleaning, drying and unloading. These machines will need to be modified due to the following:

- The machines are not closed, so the operators will unavoidably have contact with solvents and inhale solvent vapors;
- There is no explosion-proof safety features and thus, the process, as set-up currently, is not suitable for the alternative solvent with slight flammability. Further, there is no solvent recovery system and as a result, the consumption is high. The cost will increase when using the alternative solvent with higher unit price.

¹ KC-3000C's main ingredient is HCFC-141b (65%) and others, much safer and better than HCFC-141b for the needle silification.

1.3 Technology Choice

Some of the zero-ODP alternatives to HCFC-141b currently available for this application are listed below:

Solvent Option	ODP	GWP	Remarks
HFC-4310	0	1,300	HFC-4310 is one of the Vertrel [®] series solvents launched by the US DuPont Company, with decafluoropentane as the principal component. It is non-toxic and non-flammable. As a silicone oil solvent, the boiling point, surface tension and viscosity index are ideal. If HCFC-141b is taken as the benchmark for comparison, HFC-4310 shows poor effects of CO ₂ emission reduction and its toxicity is higher than HCFC-141b. Moreover, it is expensive and the price is as high as US\$ 70/kg.
HFC-365mfc	0	840	While this option offers good solvent properties, with respect to HCFC-141b, it has a higher GWP. It is also flammable in the range of 3.5% - 9% by volume in air, thus safety becomes a significant barrier for adoption. It is also more expensive than HCFC-141b with a cost of about US\$ 22/kg.
KC-3000	0	750	KC3000 is a HFC-365mfc-based mixed solvent. It is compatible with most kinds of materials, not easily flammable, non-toxic and volatile and its chemical properties are stable. Its inadequacy is that it has a certain degree of flammability. The cost is about US\$ 12/kg.
HFE-7100	0	480	HFE-7100 is a fluoride based solvent launched by 3M [®] Corporation. It is non-toxic, non-flammable and has a relatively low GWP. As a silicone oil solvent, its boiling point, surface tension, and viscosity index are ideal. Although its boiling point is higher than HCFC-141b, its latent heat of evaporation is 40% lower than HCFC-141b, therefore, when the needle tube and the outer sleeve are silicified, the solvent is easily volatile, leaving little residue. Its surface tension is 26% lower than HCFC-141b, but its silicone oil dispersion and coating properties are better than HCFC-141b. Its GWP is lower than HCFC-141b. However, its main disadvantage is its cost, which is in the range of US\$ 60/kg.
KC-6	0	<20	KC-6 is a new generation of environment-friendly medical silicone oil thinner developed by Beijing Aerospace Technology Innovation Co., Ltd., in light of the actual situation of China's medical device industry. It is a combination of Siloxanes, Isoparaffin, etc. Its shortcomings are that it has certain degree of flammability, a high boiling point, and is less volatile as compared to the current technology. Its cost is favorable at about US\$ 6.8/kg.

There are other alternatives available or under development. But due to their high GWP, flammability, performance, implement ability or costs, they were not considered to be viable. On the other hand, while adopting KC-6 as an alternative solvent, one should consider the following impacts:

Safety

KC-6 is flammable, although it has a higher flash point. When it is used by the medical device industry in clean rooms, particular attention needs to be given to safety due to the accumulation of solvent vapors, and necessary precautions have to be taken. With those measures taken, its flammability could be controlled.

Silicification performance

KC-6 has a higher boiling point; after silicification, its evaporation rate will be slower than HCFC-141b. In accordance with the current practice, as soon as the needles are silicified, they will be turned upside down. Thus, if the solvent cannot be evaporated in time the silicification fluid will flow to the needle hub, causing the absence of silicone oil in the needle tip and the contamination of the needle hub and silicification tooling. In order not to reduce the output, air dryers will need to be installed on the assembly line.

Biocompatibility and drug compatibility

Puncture instruments are devices that enter human tissues and may come into contact with blood. As KC-6 is a mixed solvent, the biocompatibility and drug compatibility of Isoparaffin, should be confirmed for patients' safety.

2. Project Implementation

The project was approved by 64th Executive Committee meeting in 2011 at a funding of US \$ 557,667. Project implementation started in 2012, all the progress milestones required by the contract were reached and verified by the end of 2013. The project successfully passed national acceptance in December, 2013.

This demonstration project proposed to modify a needle assembly line and an ultrasonic cleaning line at Zhejiang Kindly Medical Devices Co. Ltd. to provide a demonstration of KC-6 technology.

According to the project implementation plan, the following activities were carried out:

I. Equipment redesign and installation

1. Ultrasonic cleaning line

In order to realize mechanized operations with minimum operator interference, human errors and exposure, the silicification tooling has a strip shape; when it is cleaned, a container is needed to hold it. Each container can hold 30 pieces silicification tooling. Thus a mechanical lifting device, instead of the manual operation of an operator, can be used to transfer automatically the containers between different working stations. In this case, the operator will not touch the solvent. These containers are an essential equipment to realize closed and mechanized operation. In addition, the containers must be designed not to block ultrasound penetration. Otherwise, the silicification tooling held within cannot get the impact of ultrasonic, and the effectiveness and efficiency of cleaning will be significantly reduced. The ultrasonic cleaning line was designed based on the following considerations:



Pic1: Silification toolings



Pic2: silification toolings with needles on

- To make the machine fully closed, and prevent operators from contact with solvents.
- To adopt the explosion-proof design, and select explosion-proof electrical appliances and equipment.
- To set up a solvent recovery system, so that solvent vapors in confined spaces and the polluted solvent residue can be recovered in time, so that solvent consumption can be reduced.
- After cleaning with the use of KC-6, an evaluation on the cleaning effects from the aspects of appearance and needle connection firmness needs to be conducted:
 - Appearance evaluation: Wipe the surface of the tooling with white paper, use a 10x magnifying glass to observe the surface of the white paper, and there should be no oil stains.
 - Connection firmness evaluation: Put a needle onto a cleaned silicification tooling, silicize the needle, and use a fastness tester to test its firmness to see whether the product is qualified.

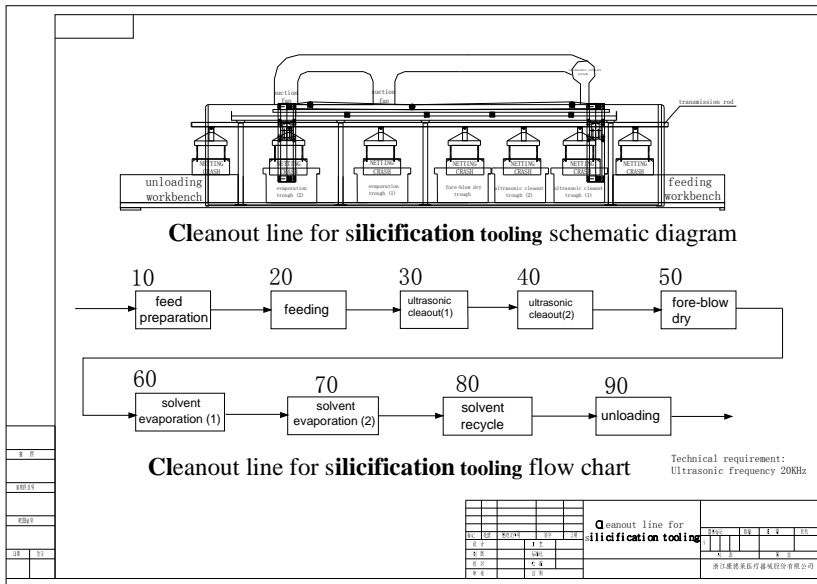

Pic3: process flow chart of cleaning line for silicification tooling

The tooling cleaning line is a LBD-6090 JRTF automatic ultrasonic cleaner manufactured by Shenzhen Liboda Technology Co. Ltd., and is composed of a set of equipment of solvent immersion and a set of 13-roller automatic scrubbing equipment and an ultrasonic cleaner which is equipped with 6 tanks. Among them, the former three are heating cleaning tanks, each can hold 30L cleaning agents and work at 50°C usually; the fourth is a gas cleaning tank, which can also hold 30L cleaning agents and work at 80°C usually. The fifth and sixth are drying tanks, which can work at the temperature from room temperature to 120°C; the last is a solvent recovery tank, with a capacity of 30L/h to 50L/h. With good operation flexibility, the working time of each working station of this cleaner could be set from 30 seconds to 60 minutes.

The cleaning for 3 minutes and cold air drying at room temperature could get good cleaning result that met the production requirements. The equipment of solvent immersion is used to soak and pre-clean clamp from the needle assembly line back to the cleaning line. Good cleaning is presented due to long time of turnover and immersion cleaning. The toolings are automatically scrubbed by the scrubbing equipment with 13 rollers to replace manual scrubbing, before they transferred into the ultrasonic cleaner. Of the 13 rollers, the former three and the last four are slow rotating rollers, while the middle six are quick rotating rollers. This scrubbing equipment is controlled through PLC, which is equipped with a set of refrigeration device for the purpose of circulating cooling of cleaning tanks. The field verification results indicated that both the drying speed and the effect of clean were good, could meet the cleaning requirements, and also conform to the specified technical requirements of the demonstration project.



Pic4: the needle-making clamp cleaning line

KC-6 清洗产品的链接牢固度记录表

时间	规格	数量	合格数	判定	备注
2014.5.12	22G	100	100	合格	
2014.5.13	22G	100	100	合格	
2014.5.14	22G	100	100	合格	
2014.5.15	22G	100	100	合格	
2014.5.16	22G	100	100	合格	
2014.5.17	22G	100	100	合格	
2014.5.19	22G	100	100	合格	

注:牢固度标准为 40N 不脱落。



KC-6 清洗产品的清洁度记录表

时间	规格	数量	与注射器配合 无脱落数	有无油污	判定	备注
2014.5.12	22G	100	100	无油污	合格	
2014.5.13	22G	100	100	无油污	合格	
2014.5.14	22G	100	100	无油污	合格	
2014.5.15	22G	100	100	无油污	合格	
2014.5.16	22G	100	100	无油污	合格	
2014.5.17	22G	100	100	无油污	合格	
2014.5.19	22G	100	100	无油污	合格	



Pic5: Link reliability test data

Pic6: cleaning quality test data

After modification, the silicification tooling cleaning lines has been adjusted according to the new features of KC-6 to meet health, safety and environment requirement.

The needle assembly line

The original needle assembly line includes eight major production processes, i.e. feeding of needle hub, assembly of needle canula, gluing adhesive, curing (in a tunnel oven), silicification, feeding of protective cap, pressing protective cap, and unloading products. Each of these processes is accomplished through special purpose-built automatic machines and devices of 1997-1998 vintage.



Pic7: Needles



Pic8: Needle assembly line



Pic9: Silicification working station



Pic10: Needles Silicification by hand

Process Changes

KC-6 has a higher boiling point and slight flammability. To address these issues, the demonstration project involved modification of production lines, process adjustments, silicification fluid management, evaluation of needle silicification effects and the effects of silicification tooling cleaning, the confirmation of biocompatibility and drug compatibility, as well as related training and technical assistance.

Process Changes Made for Needle Assembly Line

Adjustment of the silicification process

Since KC-6 has certain flammability, in order to control the concentration of the clean room within flammable limits, KDL installed an explosion-proof local exhaust ventilation hood near the silicification tank to discharge as much as possible the volatile solvent vapors outside the clean room. All local ventilation hoods that have been installed in the clean room can be connected together to form a ventilation system during the entire phase-out in the enterprise in the future.

Addition of vacuum dryer

As KC-6 has a higher boiling point, the solvent cannot be volatilized in a timely way. So the silicification fluid will flow to the needle hub, causing the absence of oil in the needle tip and the pollution of the needle hub and silicification tooling. Therefore, in order to accelerate evaporation, a vacuum drying process was added after the silicification process.

Technological adjustments

Due to the use of a new solvent, the technical process of the whole assembly line has to be adjusted moderately:

Production process: Because of the addition of the vacuum drying process, the operation speed of the assembly line, the quantity of tooling allocated and the work-piece making sequence were adjusted accordingly;

Ventilation system: In order to prevent the accumulation of solvent vapors in the clean room, KDL increased the volume of outdoor air for dilution and to add fresh air, so that a positive pressure can be ensured in the purification room.

Management of silicification fluid

As a result of using a new solvent, KDL adjusted the silicification fluid management methods, including: compounding methods, the indicators and methods for controlling the concentration of fresh silicification fluid and the concentration and control indicators of silicification fluid in the tanks varying with the change characteristics of the duration of silicification, its control methods, testing methods of control indicator and equipment adjustments. A recovery system was built to recover the solvent of the residual silicification fluid that has already lost effectiveness; explosion-proof security measures were taken to achieve a unified storage of the residue.

Evaluation of needles silicification

After using the new solvent, the effects of needle silicification was evaluated from two aspects:

Appearance evaluation: Evaluate the dispersion of silicone oil, oil amount at the needle tip and the pollution condition of the needle seat;

Puncture force evaluation: Use the needle sharpness tester for testing; investigate the magnitude of force, the peak value position and the waveform of force.

The needle assembly line installed

The needle assembly line was installed at the new workshop of KDL, consisting of a needle seat system, a needle tubing system, a gluing system, a drying system, an image-processing system, a block-inspecting system, a needle-silicifying system, an insert-inspecting system, an upper cover system, a needle-removing system, an electric control system and so on. The needle-silicifying system involved in this equipment is well sealed that uses KC-6 as the solvent, in which the tooling can roll over automatically. The volatilized solvent after silicification is pulled to outdoor through the vent pipe on the side of the silicifying tank to address the safety risks. The previous silicifying equipment has the function of silicification and block-checking, while the new equipment adopted the technology of laser and rapid photography, in which the inspection of block will be completed before silicification. That is, the new silicifying system is only responsible for silicification. The new equipment can meet the demand of the production, as for the high automation, high detection sensitivity and reasonable safety precautions judged from the run of the equipment.

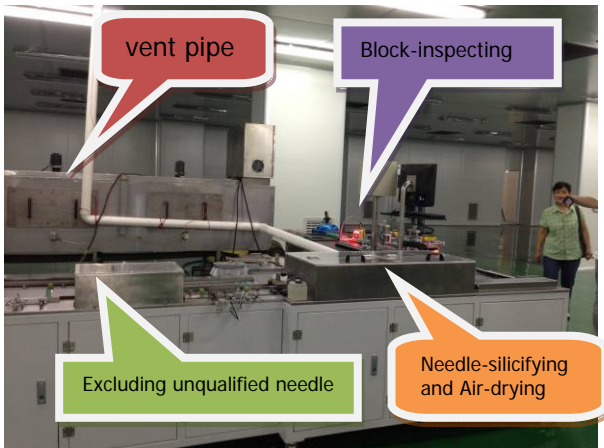

Pic11: Converted needles assembly line

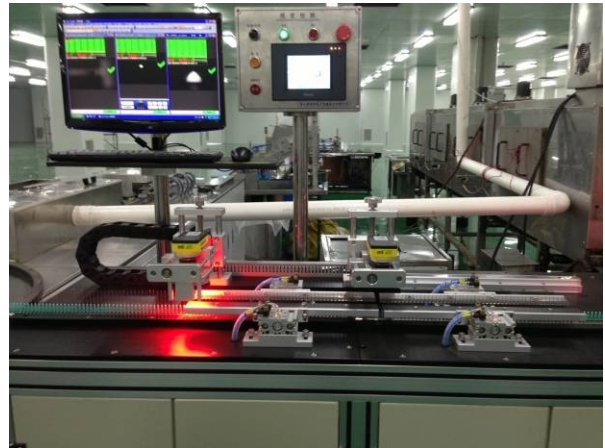

Pic12: Block-inspecting system

When the needle assembly line was put into production, KDL made a lot of tests on the puncture force. For the 0.9mm needles, the puncture force with KC-6 is 0.51N, a little better than that with HCFC-141b (KC-3000), which need 0.53N.

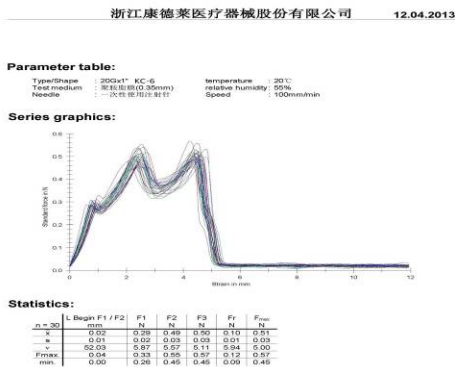

Pic13: Puncture force evaluation with KC-6

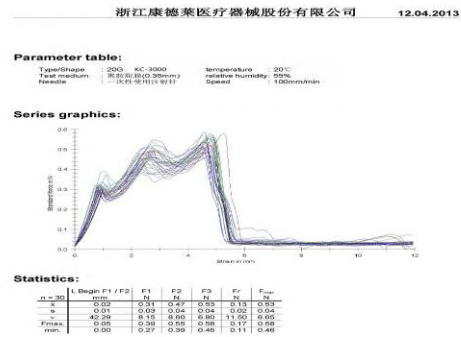

Pic14: Puncture force evaluation with HCFC-141b

II. Workshop modification for KC-6

Before all the equipment conversion work of demo project in the new plant, KDL carefully prepared the constructions with more fire prevention materials, fixed a ventilation system in large scale in all the workshops using KC-6, placed the new ultrasonic cleaning line and silicification fluid in independent room respectively. All workshops producing needles are furnished according to the Medical Devices Production Standard.

The cleaning line was installed in another building, far away from needles production workshops.

After the workshop modification, KDL applied for the fire prevention inspection of construction project, Medical Devices production license and contaminant discharge license for the responsible administration department, and got the Medical Devices production license on 16 September 2013; got the contaminant discharge license on 10 October 2013; got approved by the local fire prevention bureau on 24 January 2013.



Pic15: License for Medical devices production



Pic16: License for pollution discharge

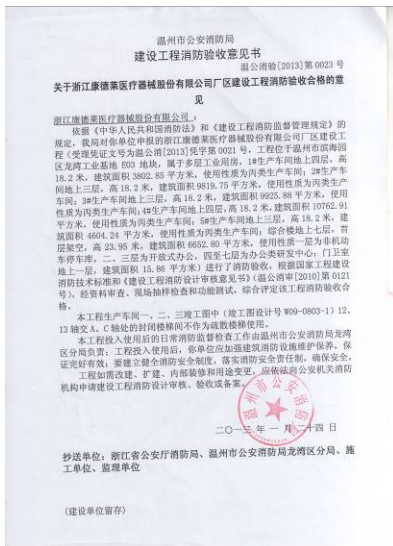

Pic17: Firefight acceptance report



Pic18: Back-up of License for pollution discharge

III. Confirmation of biocompatibility and drug compatibility

In 2012, KDL submitted the needles siliconized with KC-6 to National Institutes for Food and Drug Control (NIFDC) to test whether the isoparaffin that remains after needle solidifications and cleaning will have an impact on biocompatibility and drug compatibility. In July 2013, NIFDC provided testing report indicating the Needles siliconized with KC-6 are well in seven major indicators according to China pharmacopeia. The result will also benefit other medical equipment device production enterprises, saving their testing time and money when utilizing this substitutes.

The durability evaluation between KC3000C, KC-6 and national standard is given in the table below.

Date	Scale	National standard (GB15811) on durability	KC3000C		KC-6		Result
			Number of needle samples	Non-qualified	number of needle samples	Non-qualified	
2014.5.12	22G	Not break off under 40N	100	0	100	0	qualified
2014.5.13	22G		100	0	100	0	qualified
2014.5.14	22G		100	0	100	0	qualified
2014.5.15	22G		100	0	100	0	qualified
2014.5.16	22G		100	0	100	0	qualified
2014.5.17	22G		100	0	100	0	qualified
2014.5.19	22G		100	0	100	0	qualified

The puncture evaluation between KC3000C, KC-6 and national standard is given in the table below.

No.	Scale	National standard (GB15811) on puncture (N)	KC3000C	KC-6	Result
1	22G	≤0.85	0.63	0.57	qualified
2	22G	≤0.85	0.59	0.55	qualified
3	22G	≤0.85	0.56	0.56	qualified
4	22G	≤0.85	0.55	0.57	qualified
5	22G	≤0.85	0.64	0.59	qualified

KDL's product has been approved by CE certification by EU and FDA factory verification.

In 2013, FECO signed HCFC-141b phase out contracts with 6 Medical Devices production enterprises, all of them selected KC-6 as suitable substitute for HCFC-141b.



中国食品药品检定研究院检验报告		
报告编号: QH201300782	共 1 页, 第 1 页	
样品名称: 一次性使用无菌注射器	样品批号: QH0502201201568	
生产单位: 浙江康德莱医疗器械股份有限公司	注册号: 0051	
供货单位: 浙江康德莱医疗器械股份有限公司	规格: 0.7*32mm	
检验目的: 合同检验	剂型/型号: /	
检验项目: 部分检验	包装规格: 1支/盒	
收样日期: 2012年11月27日	有效期至: 2015年10月	
样品数量: 200 袋	密封数量: /	
检验依据: 约定方法		
检验项目	标准规定	检验结果
药物相容性		
地塞米松相容性	样品与空白对照针头相比, 药液浓度比应在 90%~110%之间	93%, 103%, 97%, 96%, 96%
盐酸布比妥因	样品与空白对照针头相比, 药液浓度比应在 90%~110%之间	101%, 100%, 98%, 98%, 102%
无菌	应符合无菌规定	符合规定
热原	应无热原反应	符合规定
细菌毒性	应不大于 1 级	0 级
皮内刺激	应无皮内刺激反应	无皮内刺激反应
皮肤刺激	应无皮肤刺激反应	未观察到; 无皮肤刺激反应
急性全身毒性	应无急性全身毒性	未观察到; 无急性全身毒性
溶血	溶血率应≤5%	0%
以下空白		
检验结论	本品按约定方法检验, 上述项目符合规定。	
授权签字人	签发日期	2013年7月25日

Pic19: Report biocompatibility and drug compatibility

IV. Demonstration

In July 2013, KDL technical manager was invited by UNDP to introduce how this demo project was implemented during the technology workshop on HCFC phase-out alternative technologies.



Pic20: Medical Device Production enterprise representations visited converted equipment by demo project



Pic21: Workshop on HCFC-141b phase-out project implementation progress, Zhejiang Wenzhou, 31, July 2013



Pic22: Solvent KC-6

V. Safety measures

With proper hardware for safety, the cleaning line was equipped with a central ventilation system above the whole line, as well as a refrigeration recycling system beside it. An independent ventilation system has been installed to discharge the solvent volatilizing from the silicifying system to outdoor, which increases the safety factor. On the other hand, KDL has formulated fire emergency plans for the two lines. These all can meet the requirements of the demonstration project.



Pic23: Concentration detector

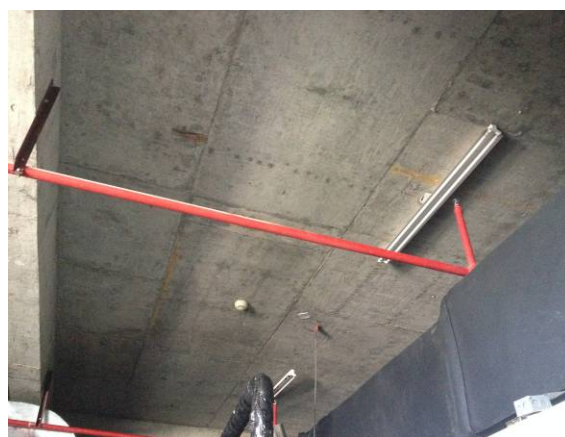

Pic24: firefighter pipes and vent pipe

Management of silicification fluid

As a result of using a new solvent, it is necessary to adjust the silicification fluid management methods, including: compounding methods, the indicators and methods for controlling the concentration of fresh silicification fluid and the concentration and control indicators of silicification fluid in the tanks varying with the change characteristics of the duration of silicification, its control methods, testing methods of control indicator and equipment adjustments. A recovery system was built to recover the solvent of the residual silicification fluid that has already lost effectiveness; explosion-proof security measures are taken to achieve a unified storage of the residue.



Pic25: Special room for silicification fluid management with vent pipe and fire pipe

Process and safety training

Training was provided to the production, installation and maintenance personnel on the physical and chemical properties of KC-6, technical adjustments of modification processes and added processes, silicification fluid management, silicification effects, methods for cleaning effect evaluation, methods of operating newly-added equipment, machine operating parameters, machine maintenance procedures, precautions and safety measures, etc.

Process and safety training were provided to the manufacturing, installation and maintenance personnel. It was verified that the internal technical acceptance were completed and technical commissioning and relevant personnel training were finished.

KDL invited KC-6 technical service to introduce matters needing attention in different stages of production and silification liquid management.



Pic26: Training workshop for workers

3. Management

The project was under the overall management and coordination of the Foreign Economic Cooperation Office, Ministry of Environmental Protection of China. UNDP was the implementing agency for the project, which provided international coordination and technical assistance.

The project employs the Performance-based Payment (PBP) mechanism in its implementation. Under the PBP mechanism, the enterprise tasked with carrying out the conversion would play the role as a key executor, which is responsible for all the activities related to the conversion. The procurement was organized fully in line with the marketing principle ensuring cost-effective and timely installation of equipment for KC-6 based manufacturing operations.

FECO and UNDP were not involved in the procurement activities of the enterprise by any means. FECO made payment to the enterprise in tranches for the costs of procurement and conversion, at agreed payment dates given in the payment schedule, and when milestones prerequisite for the tranche have all been achieved on time.

Before each payment, FECO invited independent experts to verify whether the performance for each milestone that the payment is contingent on has been satisfied. The verification reports were submitted and accepted by UNDP as the main supporting documents for requesting the installment of payment.

During project implementation, FECO and UNDP organized 5 verification missions combined with monitoring and evaluation at KDL factory - once in 2011, once in 2012 and 3 times in 2013. The experts group included technology experts and finance experts, FECO staff and UNDP staff as well. The experts team traced the project implementation situations, evaluated the project technical issues and progress, and verified whether the performance for each milestone of the respective payment has been satisfied. Each verification activity was carried out in a process of planning, preparation, data confirmation, technical material checking, on-the-spot investigation, result confirmation and conclusion.

4. Outcomes

The project was completed and has successfully passed national acceptance in December 2013. The production line is in commercial operations, and the IOC has been disbursed to the enterprise in April.2014. The suitability of KC-6 technology as a viable replacement for HCFC-141b as a solvent in the manufacture of needles at Zhejiang KDL was established.

The following are the important outcomes of the project.

- The enterprise completed the redesign and production process of the needle assembly line and ultrasonic cleaning line in 2012.
- Equipment for modification of ultra-sonic cleaning line and a half-automatic needle assembly line was procured in 2012.
- Needle assembly line and ultra-sonic cleaning machine converted and verified in 2013.
- Demonstration was presented to other Medical Devices Production Enterprises in 2013.
- Technical commissioning was completed successfully and relevant personnel were trained in 2013.
- The project successfully passed national acceptance in December 2013.

5. Technical performance

- KC-6 has a zero ODP and very low GWP, thus it is ozone-layer friendly but also climate-friendly.
- KC-6 is a mixture, whose components are easily available on the market at favorable costs through domestic production;
- KC-6 has a higher boiling point than HCFC-141b; as a solvent, it is less volatile and therefore has less dissipation and result in less consumption;
- KC-6 exhibits good solvent properties for silicone oil, removing silicone oil from contaminated tools quite easily. The compound is clear and transparent, with good coating quality on the surface of needles;
- Due to its chemical stability and high flash point and boiling point, its comprehensive emission reduction and environmental benefits turn out to be much better than the HCFC-141b-based solvents currently use;
- The compound can be used as both the silicone oil thinner and the cleaning agent, therefore, allows relatively easy management of procurement, storage and handling;
- The KC-6 has been applied to other several Medical devices production enterprises in China. Thus, the performance has potential to be promoted.

6. Project management and monitoring

6.1 Project progress

The project was implementing smoothly according to the program schedule, and was completed by the end of 2013. It successfully passed national acceptance in December 2013. The capacity of the production line has been converted to use substitute solvent.

Each of milestones was achieved and verified, the details are as follows:

Milestones		Status
1 st	Signing of the contract	FECO and the enterprise signed contract in March 2012
2 nd	KDL sign the procurement contracts with conversion equipment suppliers	Finished in October 2012
3 rd	Conversion equipment was installed in KDL	Finished and verified in July 2013
4 th	The trial run of conversion equipment was verified by expert team	
5 th	National acceptance	Finished and verified in December 2013
6 th	Submit half-year run report and financial vouchers to FECO	Finished and verified in April 2014

6.2 Conversion cost

Total Project Costs

The total contract amount signed with the enterprise is US\$ 510,662 including ICC US\$ 305,046, and IOC US\$ 205,616.

Incremental Capital Costs

The actual incremental capital costs for conversion was US\$ 360,005 among which US\$ 352,051 was funded by the MLF, and the US\$ 7,954 was co-financed by the enterprise. The details of ICC are as follows:

No.	Item/Description	Grant funds (US\$)	Counterpart funds(US\$)	Actual cost
1.	Needle assembly line modifications (Local exhaust device; air dryer; Conveyor modifications; Intermediate inspection bench; Installation and commissioning; Electronics adjustment and debugging)	96,763	0	96,763
2.	Process Adjustments (Additional silicification tooling, Conveyor to transfer workpieces from silicification tooling to dryer)	10,884	7,954	18,838
3.	Silicification fluid management (Closed liquid mixer ;Safety features (alarm, ex-proof electricals); Digital rotary viscometer; Residue processor)	42,950	0	42,950
4.	Silicification tooling line modifications (Modification of ultrasonic cleaning line and mechanization; Workpiece loading container; Solvent recovery system; Installation and commissioning; Electronics adjustment and debugging)	121,845	0	121,845
5.	Performance evaluation (Puncture testing; Biocompatibility testing; Drug compatibility testing (statutory authorities) ;Silicification form evaluation; Silicification durability evaluation)	27,103	0	27,103
6.	Other (Design and technical expert fees, technical assistance Process; trials Process and safety training Documentation; reporting and information dissemination (UNDP) ;Project management(FECO) ;External monitoring and experts verification)	52,506	0	52,506
	Total	352,051	7,954	360,005

Note: Contingency of USD15,000 was mainly disbursed for process adjustment and silicification tooling line modification (smoke detector and alarming system). The amount of USD15,000 is already included in these two line items.

Incremental Operating Costs

The approved total incremental operating costs calculated for one-year duration amount to US\$ 205,616. The production line is in commercial operations and the IOC has been disbursed to enterprise in April.2014. The actual amount of incremental operating costs was US\$ 217,600, US \$ 205,616 was from bilateral cooperation of the Government of Japan. US \$ 11,984 was co-financed by the enterprise.

The cost for the baseline HCFC-141b based two-stage systems are summarized as below:

1. HCFC-141b price is US\$ 2.66/kg
2. KC-6 price is US\$ 6.8/kg (*exchange rate changes a lot from 2009 to 2013*)

Incremental Operating Costs

Item	KC-6 consumption in one year(kg)	HCFC-141b consumption in one year(kg)	Reasons
An ultrasonic Cleaning line	25,000	21,840	Tooling cleaning times frequency increased, from one time in half a month into one time in a week
A needle Assembly line	7,000	5,980	Air dryer after silification speeds solvent volatilization, the dryer took more solvent than actual coated in needle
Total	32,000	27,820	

7. Impact

Environmental Impact

The HCFC-141b consumption during 2009 at Zhejiang Kindly Medical Devices Co. Ltd. was 27.82 metric tonnes.

Substance	Quantity	ODP	GWP	CO ₂ -eq emissions
HCFC-141b	27.82	0.11	725	20,169
KC-6	32	0	20	640
Impact		(3.06)		(19,529)

Based on the above, the successful implementation of this project will result an annual reduction of minimum 3.06 ODP tonnes and annual direct emission reductions of 19,529 tonnes CO₂-eq.

Results

The successful implementation of this project resulted in the following:

- (a) Sustainable reductions in HCFC consumption in the Solvents sector in China of 3.1 ODP tonnes, contributing to China's compliance with the 2013 and 2015 control targets
- (b) Demonstration and availability of an environmentally safe and cost-effective alternative for enabling replication of this technology in similar applications and enterprises in the Medical Cleaning Applications sub-sector in China. It must be noted that results of KDL project are already being used by companies in China for phasing-out HCFC-141b in select solvent applications with KC-6.



Establishment of a Private-Public Financing System for Disposal of ODS for Indonesia

March 2014

Prepared for

The World Bank Group
1818 H Street NW
Washington, DC 20433

Prepared by

ICF International
1725 Eye Street, Suite 1000
Washington, DC 20006

blank
page

Contents

1. Background	1
2. Inventory Development	3
2.1. Development of Inventory Tool.....	3
2.2. Data Collection in Indonesia	3
3. Building Capacity to Undertake ODS Destruction Projects	4
3.1. Guidance on the Management of Unwanted ODS	4
3.2. ODS Destruction Capacity.....	5
4. Financing Options for Destroying Unwanted ODS	6
4.1. Available Markets for ODS Destruction Credits	7
4.2. Cost Considerations.....	12
4.3. Market Prices.....	14
5. Evaluation of Options for Indonesia.....	14
6. Next Steps	15
6.1. Establishing a System for the Long-Term Management of ODS	16
7. References.....	18
Appendix A. Workbook on the Management of Unwanted ODS in Indonesia	A-1
Appendix B. Importance of Evaluation Criteria Relative to Financing Options	B-1
Appendix C. Potential Project Developers	C-1
Appendix D. Sample Terms of Reference for Project Developer	D-1

blank
page

Acronyms and Abbreviations

Acronym / Abbreviation	Stands For
CCO	Chemical Control Order
CDM	Clean Development Mechanism
CFC	chlorofluorocarbon
DRE	destruction and removal efficiency
EOI	expression of interest
GHG	greenhouse gas
GWP	global warming potential
HCFC	hydrochlorofluorocarbon
HFC	hydrofluorocarbon
kg	kilogram
km	kilometer
LVC	low volume consuming country
MLF	Multilateral Fund
MoE	Ministry of Environment
MRV	measurement, reporting, and verification
MtCO ₂ e	million metric tons carbon dioxide equivalent
NCCC	National Council on Climate Change
NCPP	National CFC Phase-out Management Plan
NCS	Nusantara Carbon Scheme
ODS	ozone depleting substance
OEWG	Open-Ended Working Group
PCBs	polychlorinated biphenyls
PMR	Partnership for Market Readiness
PMU	Project Management Unit
tCO ₂ e	metric tons carbon dioxide equivalent
TEAP	Technology and Economic Assessment Panel
ToR	terms of reference
UNEP	United Nations Environment Programme
UNIDO	United Nations Industrial Development Organization
VCS	Verified Carbon Standard
VCU	verified carbon unit

blank
page

1. Background

The Montreal Protocol on Substances that Deplete the Ozone Layer has been immensely effective at reducing the production and consumption of ozone depleting substances (ODS) worldwide. While the production and consumption of ODS has dramatically diminished, a large amount of ODS still remains in equipment, products, and stockpiles held by country governments as well as industrial and commercial users. Because emissions from ODS banks are not explicitly controlled by the Montreal Protocol, there is significant risk that these ODS will be released to the atmosphere, contributing to both ozone depletion and global climate change. Many countries have enacted regulations that prohibit the venting of ODS; however, regulations alone are often not enough.

To prevent inadvertent or intentional emissions of ODS banks, financial incentives must be put in place to encourage proper management and ensure eventual destruction of this unwanted material. The high global warming potential (GWP) of ODS means that their destruction has the ability to generate significant volumes of carbon credits. Indeed, a study prepared for the World Bank in 2010 found that opportunity exists for financing the destruction of ODS through the voluntary carbon market (ICF 2010).

To help countries operating under Article 5(1) of the Montreal Protocol take advantage of this opportunity, ICF International was commissioned by the World Bank to explore options for engaging the private and public sectors in financing the destruction of unwanted ODS in Indonesia.¹ The remainder of this report provides a summary of the results of this effort, including the following:

- ❖ Development of an inventory of unwanted ODS (Section 2);
- ❖ Building capacity (Section 3);
- ❖ Exploring options for destroying unwanted ODS (Section 4);
- ❖ Evaluation of options for Indonesia (Section 5); and
- ❖ Next steps (Section 6).

Financing the Destruction of ODS through the Voluntary Carbon Market

The 2010 study prepared for the World Bank assessed opportunities for financing the destruction of unwanted ODS through the voluntary carbon market. The study concluded that there is a market for ODS destruction through frameworks such as the Verified Carbon Standard and Climate Action Reserve. The study recognized that some challenges do exist, but that overall the voluntary market is likely a win-win opportunity.

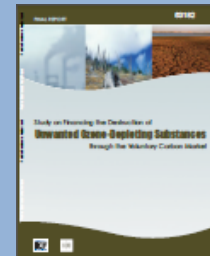

For more information, see the full report online: <http://documents.worldbank.org/curated/en/2010/02/14551009/study-financing-destruction-unwanted-ozone-depleting-substances-through-voluntary-carbon-market>.

¹ As part of this work, ICF also explored options for engaging the private and public sectors in financing the destruction of unwanted ODS in the Philippines. The outcome of this activity is documented in a separate report.

Long Term Approach for Recovery, Collection, and Management of ODS

There are three main sources of ODS: (1) ODS stockpiles that are obtained by Customs when illegally imported into the country; (2) ODS recovered from large equipment (e.g., chillers) during decommissioning; and (3) ODS recovered from small equipment (e.g., household refrigerators, window air conditioning units) at end-of-life. A phased approach should be undertaken to ensure systems are established to properly manage each source of ODS.

Phase 1: ODS Stockpiles from Illegal Imports – Destroying illegally imported stockpiles of ODS represents the first phase of ODS management. ODS stockpiles are owned by the government and are often stored at a central location, making them the easiest source of ODS to manage. However, stockpiles of ODS that are left unattended will slowly vent to the atmosphere. Therefore, prompt disposal is necessary to avoid emissions.

Phase 2: ODS Recovered from Large Equipment – The second phase of ODS management involves collection and destruction of ODS recovered from large equipment. When large pieces of equipment such as chillers are decommissioned, the refrigerant is often recovered since there is an economic incentive to reuse it for the servicing of other equipment. Additionally, many countries have regulations in place that require the recovery of ODS from large equipment. Retired chillers that use large amounts of refrigerant provide a steady stream of ODS that, if not reused, will be stockpiled and eventually vented into the atmosphere. The development of systems to collect and destroy ODS from retired large equipment is needed to ensure proper management of ODS from this source. Establishing these systems now is also important for the future management of HFCs.

Phase 3: ODS Recovered from Small Equipment – The third phase of ODS management involves ODS recovered from appliances such as refrigerators, freezers, and air conditioners, which historically used CFCs and now largely rely on HCFCs and HFCs. Individually, these pieces of equipment contain only a small amount of refrigerant (e.g., 0.13 – 2 kg). Thus, there is little economic incentive to recover this material. However, with more than 65 million households in Indonesia (Statistics Indonesia 2009), collectively, the refrigerant that can be recovered from small equipment represents a significant opportunity for generating carbon credits from destruction. To prohibit venting and ensure refrigerant is recovered at end-of-life, regulations should be established along with collection and recycling programs. The United States, Brazil, Mexico, and many countries in Europe have already established appliance recycling programs to encourage the proper management of ODS. Establishing these collection centers now is also important for the future management of HFCs.

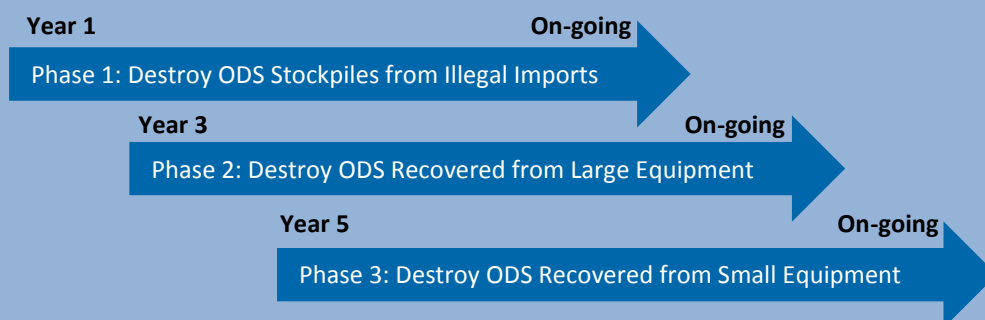

2. Inventory Development

As a first step to managing banks of unwanted ODS, an inventory detailing the quantity, type, purity, location, and ownership of the material must be developed. This step was completed in two parts: through (a) the development of an inventory tool and (b) data collection and tool population, as described in the sections that follow.

2.1. Development of Inventory Tool

To assist country governments in the development of an ODS inventory, an Excel-based inventory tool was developed. The inventory tool is designed to collect information on ODS contained in stockpiles, chillers, and other equipment (e.g., refrigerators and air conditioners). The inventory tool also includes a summary table that auto-completes to show total quantities of unwanted ODS held domestically. A detailed description of the inventory tool along with guidance on how to populate the tool is presented in the Workbook provided in Appendix A.

ODS Stockpiles

Stockpiles of ODS are generally stored in cylinders within large facilities and warehouses. These cylinders are often pressurized and can be distinguished using color, pressure, size, weight, or shape. The refrigerant industry typically universally distinguishes the type of refrigerant in a cylinder primarily based on color and pressure. These stockpiles of ODS are often consolidated into larger cylinders or storage tanks prior to destruction to avoid additional shipping expenses.

2.2. Data Collection in Indonesia

To populate the inventory tool, information on stockpiles of unwanted ODS in Indonesia was compiled by a local consultant through consultation with Indonesian Customs officials and the Indonesian Ministry of Environment (MoE). It was identified that illegally imported ODS was seized on seven different occasions between February 2004 and June 2009. Through further discussions, it was confirmed that all confiscated material that was seized was refused entry into the country and no longer resides in Indonesia. A summary of these seizures is provided in Table 1 below. Table 2 that follows summarizes these seizures by ODS type and quantity.

Table 1: ODS Seizures by Indonesian Customs (2004-2009)*

#	Port	Date	ODS Type	Quantity (kg)
1	Tanjung Priok	2/11/2004	CFC-12	10,132
2	Tanjung Emas	3/24/2004	CFC-12	31,280
3	Tanjung Emas	9/3/2007	CFC-12	39,535.2
			CFC-11	4,000
			HCFC-141b	4,000
4	Tanjung Balai Karimun	10/1/2007	CFC-12	3,372.8
5	Tanjung Priok	3/25/2009	CFC-12	15,504
6	Merak	5/25/2009	CFC-12	53,883
7	Pontianak	6/2/2009	HCFC-22	15,572

* All seized imports have since been exported from Indonesia.

Source: Pasek (2013).

Table 2: Seized ODS Imports by Type and Quantity (2004-2009)*

Chemical	Seized Stockpiles	
	kg	tCO ₂ e
CFC-11	4,000	19,000
CFC-12	153,707	1,675,406
CFC Subtotal	157,707	1,694,406
HCFC-22	15,572	28,185
HCFC-141b	4,000	2,896
HCFC Subtotal	19,572	31,081
R-404A	367.2	1,440
R-407C	312.8	477
R-410A	15,504	32,372
HFC Subtotal	16,814	34,289
TOTAL	194,093	1,759,776

* All seized imports have since been exported from Indonesia.

Source: Pasek (2013).

Information available on the inventory of ODS in chillers was also compiled. The inventory, summarized below in Table 3, is based on information previously compiled for the Indonesia Chillers Energy Efficiency project, which is known to only represent a small portion of the installed base of chillers in Indonesia. Additional efforts will need to be undertaken to expand the chiller inventory and develop an inventory of ODS contained in other equipment (e.g., refrigerators/freezers) and that recovered by service technicians during maintenance.

Table 3: Indonesia Chiller Inventory*

Chemical	Chiller Inventory	
	kg	tCO ₂ e
CFC-11	6,230	29,593
CFC-12	3,640	39,676
TOTAL	9,870	69,269

* The inventory presented is known to be incomplete.

Source: Pasek (2013).

3. Building Capacity to Undertake ODS Destruction Projects

3.1. Guidance on the Management of Unwanted ODS

To assist countries operating under Article 5(1) of the Montreal Protocol to take advantage of the opportunity to finance the destruction of ODS through the carbon market, a *Workbook on the Management of Unwanted ODS* was developed. The workbook, which was developed by ICF under contract with the World Bank, is intended to serve as a general guide on how to manage unwanted ODS held by country governments. The workbook includes information on the following:

- International agreements that govern the movement of ODS;
- Guidance on how to develop an inventory of unwanted ODS;

- Guidelines for proper handling of unwanted ODS; and
- An overview of the project assessment and development process, including strategies for engaging the public and/or private sector in an ODS destruction project.

To inform this report, an overview of relevant domestic regulations in Indonesia is provided in the version of the workbook presented in Appendix A. The MoE is expected to review and further populate the workbook with detailed country-specific information. In addition, the MoE is expected to take the time to understand the systems that must be put in place to properly handle unwanted ODS, and to identify possible improvements to their national systems and regulations. Ensuring that these systems are in place now is critical for preventing the venting of these chemicals and ensuring eligibility under various carbon markets not only today, but also in the future as more ODS (and possibly other harmful chemicals) are phased out of the global market. Further discussion on implementation of a long-term approach to the management of ODS and other F-gases is found in section 6 of this report.

Key Indonesian ODS Regulations

- Minister of Industry and Trade No. 110/MPP/Kep/1/1998
- Government Regulation No. 18/1999
- Government Regulation No. 74/2001
- Minister of Trade No. 24/M-DAG/PER/6/2006
- Minister of Industry No. 33/M-IND/PER/4/2007
- Minister of Trade No. 03/M-DAG/PER/1/2012

3.2. ODS Destruction Capacity

In addition to properly managing ODS, feasible options for the disposal of ODS should also be explored. In 2002, TEAP identified a variety of technologies that can be used to destroy ODS, which include:

- **Incineration technologies**, which use a controlled flame to destroy ODS in an engineered device. Common technical options, such as rotary kilns and cement kilns, use hydrocarbon fuels, while reactor cracking is fuelled by hydrogen. Incineration technologies are commonly used worldwide and offer high destruction capacity at a relatively low operating cost.
- **Plasma technologies**, which use intense heat from plasma to destroy ODS. Specific options are differentiated according to the method of plasma generation. Some have the advantage of being compact and portable, yet require a significant amount of energy to operate as well as trained technicians to service and maintain the equipment.
- **Other non-incineration technologies**, which destroy ODS without using incineration or plasma-based techniques. Some of these techniques, such as solvated electron decomposition, operate at relatively low temperatures and use chemical processes to destroy the material. Those that operate at high temperatures, including superheated steam reactors, use hydrogen or hydration to break apart the ODS molecules.

Indonesia's Local Destruction Capacity

In Indonesia, ODS destruction capacity already exists. Specifically, in 2006–2007 the cement kiln at Holcim Indonesia's Narogong facility, located in Jakarta, was retrofitted to destroy ODS. The process of retrofitting the Holcim plant was led by the Indonesian MoE and Japanese MoE in 2005.

Cement kilns are used by the cement industry to convert limestone into clinker, a precursor to cement. They typically operate at temperatures of over 1,600°C. Because of their high temperatures and their need for fuel, cement kilns are co-utilized around the globe for the purposes of hazardous waste destruction, including ODS destruction. In 2005, at the time of project inception, Holcim's Narogong cement kiln was already a permitted hazardous waste destruction facility capable of destroying polychlorinated biphenyls (PCBs). Thus, to render it capable of destroying ODS, only the addition of an ODS injection system and performance testing were needed.

This injection system was installed by Holcim beginning in October 2006. The additions consisted of an ODS feeding station, flowmeters, valves, a valve train, control valves, and piping to the main burner. Tests were then conducted to determine the facility's performance. The destruction and removal efficiency (DRE) was determined to exceed 99.9999%. The facility was also found to meet or exceed all national emissions standards for hazardous waste destruction facilities. Periodic testing is required to confirm that the plant continues to meet these standards.

As of February 2013, 19 tonnes of ODS have been destroyed at the Holcim facility. The kiln has a total feed rate 550 metric tons per hour. As part of this flow, approximately 50 to 80 kg of ODS can be fed into the kiln per hour, resulting in a capacity of 1 tonne of ODS per day. The energy use for destroying the ODS as part of cement operations is negligible, given that ODS destruction represents a maximum of 0.01% of the kiln's input feed on any given day, and that the kiln would operate regardless of whether ODS is destroyed or not.

The cost of readying the facility for ODS destruction totaled nearly US\$150,000. Approximately US\$90,000 of this expense was spent on equipment modification, US\$15,000 was used for detail engineering, and US\$22,500 was spent on emission testing. Meetings, workshops, training, and travel cost approximately US\$22,500. While ODS shipping costs vary widely based on volume and distance, Holcim estimates that the shipment of a 20-foot container containing 5.5 tonnes of ODS from Medan in North Sumatra to Narogong (roughly 2,000 km) would cost US\$2,000 to US\$2,500—or approximately US\$0.00018 to US\$0.00023/kg/km. Destruction costs (e.g. for labor, power, test/monitoring of exhausting gas) are approximately \$5 per kilogram, regardless of ODS type.

Sources: ICF (2010); MoE (2013)

4. Financing Options for Destroying Unwanted ODS

The ability to finance the destruction of ODS through the voluntary carbon market is based on two key factors: (1) the availability of a basic market structure to support ODS destruction, and (2) sufficient demand in the market for carbon credits from ODS destruction projects (ICF 2010). While the market structure is known to exist—through both the voluntary and compliance carbon markets—the demand

for carbon credits from ODS destruction projects remains uncertain. In addition, due to the criteria established for market-specific offset programs, not all markets currently allow for the inclusion of carbon credits generated from the destruction of ODS sourced internationally. The remainder of this section explores the feasibility of generating ODS destruction carbon credits from existing and anticipated carbon markets, and the implications for financing ODS destruction in Indonesia.

ODS Destruction Projects: 2012 Market Share

In 2012, there was a notable market for ODS destruction projects, as shown in Figure 1. While ODS destruction credits represented roughly 7% of all offset credits generated globally in 2012, the majority of these projects were aimed at U.S. preparations for the California cap-and-trade compliance market, which require the ODS to be sourced from within the United States.

Figure 1: Market Share by Project Type, 2012

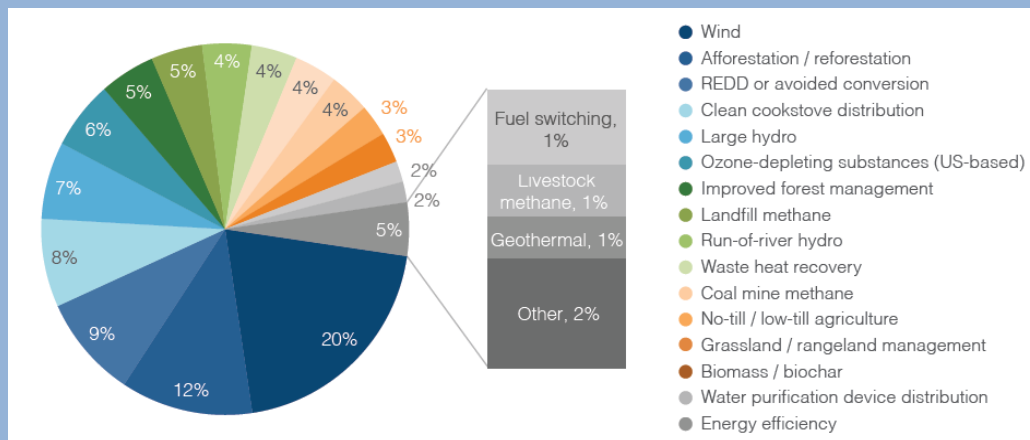

Source: Ecosystem Marketplace (2013)

4.1. Available Markets for ODS Destruction Credits

Although a number of voluntary and compliance carbon markets exist, only some allow for the generation of carbon credits from the destruction of ODS and even fewer allow for the generation of carbon credits from the destruction of ODS sourced from Indonesia. Currently, ODS destruction projects are not eligible for offset credits under the Kyoto Protocol or its flexibility mechanisms (i.e., the Clean Development Mechanism). ODS destruction projects with material sourced outside the United States or Canada are also not eligible for offset credits under California's or Quebec's compliance programs.

The existing international platforms that are available to finance the destruction of ODS from Article 5 countries include the Climate Action Reserve (the Reserve) and the Verified Carbon Standard (VCS). In addition, national carbon markets have been or are currently being established in a number of Article 5 countries throughout the world as a result of the Partnership for Market Readiness (PMR) program, and

ODS offsets may be eligible in these national markets. The opportunity to use these existing and anticipated frameworks to finance the destruction of ODS is discussed below.

ODS Destruction under the Compliance Market in California and Quebec

California and Quebec have both established cap-and-trade programs, setting an enforceable compliance obligation beginning with the 2013 GHG emissions. Under both programs, ODS destruction offset credit protocols have been adopted. However, in order to be eligible for credits under these programs, all ODS must originate domestically.

The destruction of ODS sourced from domestic material is currently the preferred project type for buyers under California’s compliance market. As shown below in Figure 2, in 2012, more than 4 million metric tons of carbon dioxide equivalent (MtCO₂e) were generated by US-based ODS destruction projects, representing roughly 7% of all offset credits generated globally. These credits were transacted at an average \$9.2/credit on average, up from \$8/credit in 2011 (Ecosystems Marketplace 2013).

Figure 2: Transacted Volume and Average Price by California Offset Type, 2011-2012



Source: Ecosystem Marketplace (2013)

While destruction of unwanted ODS from developing countries—including Indonesia—are not eligible for credits under either California’s or Quebec’s compliance program, these programs serve as a valuable example for future compliance markets that may be established in other countries at the national level. Furthermore, these markets should be monitored closely as it is possible that in the future they will support inclusion of ODS destruction projects that generate credits with material sourced from developing countries.

Destruction under the Climate Action Reserve, “The Reserve”

The Reserve is a nonprofit organization that establishes standards for carbon offset projects, oversees independent third-party verification bodies, issues carbon credits generated from such projects, and

tracks the transaction of credits over time. In late February 2010, the Reserve adopted two new offset project protocols for ODS destruction. The protocols, which serve as standardized approaches for quantifying and monitoring reductions in GHG emissions from ODS destruction projects, are for material sourced domestically and for ODS imported into the United States from Article 5 countries.

Per the latter protocol, material that resides in Indonesia can be destroyed for carbon credits under the Reserve; however, some limitations do exist. Specifically, only Annex A, Group I CFCs (i.e., CFC-11, CFC-12, CFC-113, CFC-114, and CFC-115) used in refrigeration applications are eligible for crediting under the protocol. In addition, material must be destroyed within the United States or its territories, and come from one of the following sources:

1. Privately held stockpiles of used ODS refrigerant that can legally be sold to the market;
2. Article 5 government stockpiles of seized ODS refrigerant that can legally be sold to the market;
3. Article 5 government stockpiles of seized ODS that cannot be legally sold to the market; or
4. Used ODS refrigerant recovered from industrial, commercial, or residential equipment at servicing or end-of-life.

In total, there have been 34 ODS destruction projects registered under the Reserve, five of which used the Article 5 protocol. Three of these projects (i.e., CAR596, CAR597, and CAR 691) involved virgin private stockpiles of CFC-12, one project (i.e., CAR826) involved mixed CFC-12 sourced from end-of-life appliances, and the most recent project (i.e., CAR955) involved virgin, government stockpiles of CFC-12 that were seized from an illegal import. A summary of these projects are provided below in Table 4.

Table 4: Article 5 ODS Destruction Projects Registered under the Reserve

Project ID	Project Developer	Source Country	Credits Registered	Date Registered
CAR596	Coolgas, Inc.	India	683,087	5/12/2010
CAR597	Coolgas, Inc.	India	551,802	10/22/2010
CAR691	Reclamation Technologies Inc.	Mexico	2,602,812	6/21/2011
CAR826	OEKO Service Luxembourg S.A.	Mexico	89,834	6/7/2012
CAR955	EOS Climate Inc.	Nepal	82,391	5/24/2013

Source: Climate Action Reserve (2013).

In addition to the projects that have already been registered, the Multilateral Fund (MLF) has recently approved several projects that intend to utilize the A5 destruction protocol under the Reserve. For example, in Mexico with assistance from UNIDO, MLF financing is being used to finance the destruction of CFC-12 collected from refrigerator de-manufacturing processes. The revenue from the credits, if generated and sold, will be used to start a self-sustaining ODS waste management system, with annual revenue from the credits being fed back into the waste management system. Similarly, in Nigeria with assistance from UNIDO, MLF funding will be used to finance ODS destruction projects, with the potential revenue from the credits being used to establish a national Appliance Replacement Programme that incentivizes recycling. A portion of the anticipated profit may also be used to improve local capacity for

ODS waste management. As another example, in Turkey with assistance from UNIDO, revenue from the destruction of ODS is intended to be used to sustain and improve Turkey's ODS recovery and collection system, with the ultimate goal of building local capacity for ODS destruction.

Project Highlights

Nepal: After confiscating an illegal import of CFCs in 2004, the Government of Nepal received MLF funding for a pilot ODS destruction project. With assistance from UNEP, Nepal considered numerous options for destroying the material (e.g., destruction within Nepal using a mobile unit; export to Japan, Indonesia, Europe, or the United States for destruction). Ultimately, export to the United States for credit generation under the Reserve was identified as the most economically and technologically feasible option. The project was successfully registered with the Reserve in May 2013. While credits from the project have successfully been generated, a buyer for the credits has yet to materialize.

Turkey: With assistance from UNIDO, Turkey is implementing a project that will involve the collection and disposal of ODS from decommissioned chillers. Depending on the purity and quantity of material, carbon credits will be generated from this project under the Reserve. The project also includes a training component to improve the capacity of local staff to execute similar projects in the future.

Destruction under the Verified Carbon Standard (VCS)

Another option for generating offset credits from ODS destruction is through the VCS. The VCS is a voluntary GHG program that issues and tracks carbon credits, also known as verified carbon units (VCUs) under the program. In late January 2010, the VCS expanded its GHG program to cover ODS by approving a series of eligibility criteria for ODS destruction projects. In September 2011 a VCS methodology (VM0016 v1.0) on the *Recovery and Destruction of ODS from Products* was approved.² This methodology can be applied to either ODS refrigerants and/or ODS blowing agents. Annex A, Group I CFCs and Annex B, Group I CFCs are currently eligible under the methodology,³ and destruction is allowed to occur in any country that can meet the technical requirements.

Given the criteria of the methodology, destruction of unwanted ODS that is sourced from Indonesia would be eligible for credits under the VCS, with the option of destruction taking place either within Indonesia or elsewhere. Although the opportunity exists, no ODS destruction projects have been registered to-date under the VCS; however, a project led by Energy Changes is currently under development.

² In addition to new methodologies that are submitted for review and approval under the VCS, the VCS also accepts projects prepared under the Reserve and CDM methodologies.

³ Annex C, Group I HCFCs are also eligible under the methodology after the host country or country from which the ODS destroyed by the project is imported implements a production or consumption phase-out. The Montreal Protocol requires a full phase-out of HCFCs in Article 5 countries starting on January 1, 2040; however, the VCS recognizes countries that phase-out ODS in advance of their Montreal Protocol phase-out deadline.

Destruction under National Carbon Markets

One possible alternative approach to the voluntary carbon market is to use initiatives that rely on national carbon markets. Under this approach, baselines for certain industries are established as country governments move towards establishing mandatory reductions for individual entities in select industrial sectors. The Partnership for Market Readiness (PMR)—a grant-based program that provides funding and technical assistance for the collective innovation and piloting of market-based instruments for GHG emissions reduction—is currently being used to help develop such initiatives, providing opportunity for companies to use ODS offset projects to meet reduction targets.

The PMR is currently made up of 13 Contributing Participants and 16 Implementing Country Participants. As of March 2013, all 16 Implementing Country Participants have received preparation funding to formulate a Market Readiness Proposal (MRP) while four countries have also received implementation phase funding. The current Implementing Country Participants are listed below:

- Brazil
- Chile
- China
- Columbia
- Costa Rica
- India
- Indonesia
- Jordan
- Mexico
- Morocco
- Peru
- South Africa
- Thailand
- Turkey
- Ukraine
- Vietnam

Establishment of a National Carbon Market in Indonesia

In 2009, Indonesia committed to reducing its overall emissions by at least 26% by 2020, and with international support to further reduce emissions by an additional 15%. As one way to reach this goal, Indonesia has begun exploring the use of market-based instruments. Key activities include:

- **Establishment of the Nusantara Carbon Scheme (NCS):** NCS is a voluntary emission reduction certification and registration scheme, intended to facilitate the development of a domestic carbon market and encourage local companies to reduce their emissions voluntarily. While still under development, the scheme is intended to function similarly to the Clean Development Mechanism (CDM), covering the six Kyoto gases, and requiring validation and verification of reductions. However, unlike CDM, the NCS plans to make sustainable development a mandatory and verifiable project requirement. Buyers of the credits will (at least initially) only consist of Indonesian entities (corporations, organizations, and individuals) who want to offset their emissions (NCCC 2013b).
- **Participation in the PMR Program:** Indonesia first expressed interest in participating in the PMR program in 2010. Since then, Indonesia has identified a number of actions to support market readiness, outlined in the country's MRP (NCCC 2013a). Actions include the development of a measurement, reporting, and verification (MRV) system for power generation plants and large/energy intensive industries, and piloting the MRV system on specific installations, including cement factories. This activity is intended to help the cement industry meet their mandatory reduction target of 3% from 2016-2020 relative to a 2009 baseline (Minister of Industry Decree No. 12/M-IND/PER/1/2012).

4.2. Cost Considerations

One of the most important considerations in determining which ODS destruction platform is appropriate is a comparison between the cost to implement the destruction project and the potential revenue.

Responsibilities for bearing project-related costs and accruing revenues will depend on the arrangements for public-private financing made by government agencies in possession of unwanted ODS. More information on these options, which include contracting out, facilitation, and serving as the project developer, is provided in Appendix A.

The overall costs associated with implementing an ODS destruction project may include the costs of collection and/or recovery, transportation, storage, testing, and destruction, in addition to one-time project-related costs, such as project preparation, validation, verification, and registration and issuance fees. The specific cost components will depend on the source of the ODS being destroyed; for example, stockpiled materials have the lowest associated costs since the material is already recovered and stored, while collecting and recovering ODS from equipment—especially in sparsely populated areas—presents higher costs associated with segregation, collection, and in some cases transport of the equipment itself (e.g., household appliances) for ODS recovery in a centralized location.

For stockpiled material (where collection costs are not applicable), the total cost from processing to destruction is estimated to be roughly US\$6–30 per kilogram. This range takes into account estimates developed by the Technology and Economic Assessment Panel (TEAP), as requested by Decision XX/7, as well as the estimated cost of destruction at the Indonesian Holcim plant. This range overlaps with an estimate from one ODS destruction project developer of US\$9 per kilogram, which includes US\$1/kg for transportation (and associated insurance) and US\$8/kg for destruction. The higher estimate for transportation costs likely include costs incurred during the export of the ODS, which is not accounted for in the TEAP estimates.

Table 5: Unit Cost for Destruction of ODS from Stockpiles and Chillers

Recovery and Destruction Steps	US\$ per kg		Sources
	Stockpiles	Chillers	
Segregation/Collection [†]	--	\$0–\$2	TEAP 2009
Recovery Processing Costs	\$4–\$25	\$4–\$25	TEAP 2009
Transport Costs (Destruction)*	\$0.02–\$0.10	\$0.02–\$0.10	Adjusted, based on TEAP 2009
Destruction Costs	\$2.20–\$5	\$2.20–\$5	MLF 2009; ICF 2010
Total	\$6.22–\$30.10	\$6.22–\$32.10	

[†]Segregation and collection costs are not included

* Transport costs for recovery are factored into the transport costs for destruction. This assessment estimates that ODS travels approximately 50 miles (80.5 km) to a destruction facility.

In addition to the costs associated with collecting, recovering, transporting, and destroying the ODS, there are costs associated with preparing, verifying, and registering the project with a carbon credit platform. These costs may vary significantly depending on the platform chosen (e.g., the Reserve, VCS,

or a national carbon market), as well as the project preparation arrangements. For example, if the country government serves directly as the project developer, it may incur costs to hire consultants to prepare project documentation; alternatively, if the project is contracted out to a developer, that developer may have in-house capabilities and thus lower costs for preparation. Table 6 presents the estimated range of project costs for ODS destruction.

Table 6: One Time Project Costs for Destruction of ODS

Activity	Cost (US\$)	Sources
Project Preparation*	Up to \$60,000, but could be substantially less for a national market or if developed in-house	<i>ICF estimate, see MLF 2009</i>
Verification	Estimates vary from a fixed cost of \$20,000, to \$0.10–\$0.30 per credit	<i>ICF estimate, see MLF 2009; ODS project developer</i>
Registry Annual and Project Fees	Reserve fees are \$500 each for annual and project fees; VCS fees are subject to the registry operator; national carbon market fees are currently undetermined	<i>The Reserve 2013b; VCS 2013</i>
Issuance Fee (per tCO ₂ e)	\$0.10–\$0.20	<i>The Reserve 2013c; VCS 2013</i>

*Includes consultant cost to prepare project documentation and support verification/registration.

The market price per ton of ODS destroyed (or ton of carbon equivalent) plays a significant role in the choice of platform, as the market price determines whether the destruction of ODS is a financially viable solution. Assuming the per-kg and one-time cost estimates for an ODS destruction project outlined in Table 5 and Table 6, respectively, the break-even carbon market price needed for destruction of 1, 10, 100, and 1,000 tonnes of CFC-12 was determined, as shown in Table 7. Carbon credits generated were calculated using the Reserve methodology with default estimates for emissions associated with substitute, transportation and destruction emissions (Reserve 2012). In this table, the break-even cost represents the price that would have to be generated in the carbon market in order to cover full project transaction and recovery, transport, and destruction costs. For the destruction project to turn a profit, the carbon market price would have to exceed the break-even price.

Table 7: Estimated Break-even Carbon Market Price for ODS Stockpiles

Project Size (Including Recovery)	Total Project Cost (thousands of US\$)*	Carbon Credits Generated (tCO ₂ e)	Break-even Carbon Market Price (US\$/tCO ₂ e)
1 tonne CFC-12 destroyed	\$84	10,239	\$8.23
10 tonnes CFC-12 destroyed	\$249	102,385	\$2.43
100 tonnes CFC-12 destroyed	\$1,896	1,023,850	\$1.85
1,000 tonnes CFC-12 destroyed	\$18,400	10,238,500	\$1.79

*Includes average costs of recovery, transport and destruction, plus average of one-time project development costs. These costs are based on those developed by TEAP, but could be higher or lower depending on the local costs of recovery, transport, and destruction.

4.3. Market Prices

Prices in the voluntary market have traditionally varied considerably depending on the type and location of the project activity, the standard to which it is developed, the perceived quality of the methodology used, and the volume transacted. This remains the case today, with credits from projects with a good “story” behind them, such as solar and other types of renewable energy, still able to command a premium. Industrial gases projects have typically earned prices on the lower end of the spectrum, when compared to solar, wind, and forestry projects. With this in mind, the average price per carbon credit in 2012 under the VCS and the Reserve are shown below in Table 8. These prices are notably higher than an estimate provided by one stakeholder, who indicated that the price of an A5 ODS destruction carbon credit sold on the voluntary market today could vary from US\$0.50 to US\$3.50 per tCO₂e.

Table 8: Average Carbon Credit Prices under Relevant Frameworks

Voluntary Market	Cost in 2012 (US\$/tCO ₂ e)
VCS	\$5.20
Reserve	\$7.10

Source: Ecosystem Marketplace (2013)

As noted earlier in the report, prices in the voluntary market are significantly lower than the average price of an ODS offset credit under existing compliance markets, which was \$9.2 per tCO₂e in 2012 (Ecosystem Marketplace 2013). While destruction of ODS sourced from Indonesia is not eligible for credits under existing compliance markets, the higher average price serves as an indicator of what the price of a carbon credit could be once a compliance market in Indonesia is established.

5. Evaluation of Options for Indonesia

As discussed in the preceding sections of this report, the platforms that are currently available to finance the destruction of ODS from Article 5 countries include the Reserve, VCS, and national carbon markets. Evaluation criteria were used to assess the viability of using each option to finance the destruction of stockpiled ODS sourced from Indonesia. The table in Appendix B summarizes the evaluation criteria used for this assessment as well as the importance of meeting each criterion relative to the financing options.

National Carbon Market:

- Indonesia is a participant in the PMR program.
 - Indonesia is in the process of establishing a voluntary emissions reduction certification and registration scheme (i.e., NCS), which currently is being designed to cover the six Kyoto gases.
 - National capacity for ODS destruction currently exists in Indonesia.
- *A national carbon market will be a viable financing option for destroying ODS in Indonesia, if it is configured to include ODS offsets.*

Verified Carbon Standard:

- The average credit price under the VCS could be high enough to cover projected project costs; this average price is lower than the average credit price under the Reserve and likely to be lower than the credit price under a national carbon market.
- Some project developers have voiced interest in developing a project under the VCS, but no A5 ODS destruction projects have been registered under the VCS to-date.
- National capacity for ODS destruction currently exists in Indonesia.

➔ *It is feasible to finance the destruction of ODS from Indonesia under the VCS.*

The Reserve:

- The average credit price under the Reserve could be high enough to cover projected project costs, with the average price being higher than the average credit price under the VCS, yet likely to be lower than the credit price under a national carbon market.
- There are national regulations that require government approval prior to the export of ODS; if this requirement is met, ODS may be exported to the United States for destruction.
- A5 ODS destruction projects have been successfully registered under the Reserve.
- Project developers have shown interest in developing additional projects under the Reserve.

➔ *It is feasible to finance the destruction of ODS from Indonesia under the Reserve, if an exemption is made to allow export of ODS material.*

Based on the assessment presented above, it is currently feasible to finance the destruction of ODS under both the VCS and the Reserve, with actual financing viability being reliant on real-time market demands and the realized market price of the generated carbon credits. It is also anticipated that financing the destruction of ODS under a national carbon market in Indonesia could be feasible in the near-term. However, the actual viability of using a national carbon market in Indonesia is ultimately dependent on the scope of the programs under development (i.e., eligibility of ODS destruction offsets).

Given the uncertainty of prices and demand for A5 ODS destructions credits under the VCS and Reserve, it is recommended that the Indonesian government focus on ensuring that ODS destruction is included as an eligible offset project under the NCS. Additionally, since destruction capacity already exists at Holcim's Narogong cement plant in Indonesia, it is recommended that the use of offsets be allowed for the cement industry to meet their reduction targets. This will create an incentive for the cement industry to finance the destruction of ODS and use the credits to comply with their cap.

6. Next Steps

Since no ODS stockpiles are known to currently exist in Indonesia, a decision on which option to use to finance the destruction of unwanted ODS is not needed at this time. Once unwanted ODS does materialize, factors such as offset eligibility, market demand, regulatory hurdles, and local capacity for destruction will need to be considered and carefully weighed to determine which option is ultimately pursued. In the meantime, the Indonesian government should focus on establishing a system for the

long-term recovery, collection, and management of ODS that is confiscated in the future, originates from servicing operations, or is recovered from large and small refrigeration and air conditioning equipment when that equipment is retired. The remainder of this section focuses on the steps that should be taken to establish this system.

6.1. Establishing a System for the Long-Term Management of ODS

Although no ODS stockpiles currently exist, the Indonesian government needs to plan for the future management of unwanted ODS (and possibly other harmful chemicals, including HCFCs and HFCs). As discussed previously, in addition to the future stream of confiscated stockpiles and mixed refrigerant coming from service industries, there is opportunity to collect ODS from chillers and other refrigerated appliances at end-of-life. Establishing a formal process now for the collection, transportation, storage and disposal of unwanted ODS and other chemicals from these sources will not only prevent harmful venting of these gases to the atmosphere, but will also maximize credit generation and potential revenue from future destruction projects. Specific activities that should be undertaken to establish an ODS management facility include the following:

- ❖ **Identify central facility for ODS aggregation and storage:** A central warehouse location must be identified to compile and store all material seized and recovered from retired or serviced equipment. At this location, the material should be stored until a volume sufficient for economically viable destruction has been stockpiled. Ideally, a secure and climate-controlled facility should be used for storage.
- ❖ **Conduct outreach and training with source stakeholders:** Customs officials, equipment service providers, and large ODS users must be made aware that a central collection facility exists for aggregated and safe disposal of unwanted ODS. They must also be educated about how the materials should be stored, transported, and tracked.
- ❖ **Designate a program manager to manage the flow and tracking of unwanted ODS.** In order for the ODS management system to function properly, someone must be responsible for the identification, transportation, tracking, and ultimately, the destruction of unwanted ODS. The role of the program manager will require coordination with ODS source stakeholders, as well as those responsible for ODS transportation, destruction, and offset project development. For example, the program manager will need to:
 - **Coordinate with ODS source stakeholders**—i.e., Customs officials, equipment servicing providers, and large ODS users—to collect and transport illegal or unwanted materials to the central storage facility when such materials become available.
 - **Implement a manifest system for tracking** ODS during transport from the original source to the central aggregation facility, and then to the destruction facility. Clear and accurate documentation will be critical for compliance with offset protocol.

- **Coordinate with ODS offset project developers** to ensure robust verification, reporting, and monitoring activities are taking place to comply with offset protocol requirements.
- **Coordinate with destruction facilities** once sufficient volume of ODS has been collected such that destruction can be undertaken in an economically viable manner.

To bolster the ODS management facility and promote its success, regulatory measures should also be pursued. In particular, ODS recovery regulations should be developed and/or enforced to ensure that technicians are not only recovering material from decommissioned equipment, but also systematically identifying and tracking what is removed.

Over time, once the system is functioning well, additional infrastructure may be added to expand the country's capability of recovering ODS and other environmentally damaging chemicals from a broader range of equipment—namely refrigerated appliances. A waste management system may eventually be established for small household and commercial refrigeration and air conditioning equipment, to ensure refrigerant is recovered from equipment at time of disposal.

7. References

Air-Conditioning, Heating, and Refrigeration Institute (AHRI). 2009. *Containers for Recovered Non-Flammable Fluorocarbon Refrigerants*. Available at:

http://www.ahrinet.org/App_Content/ahri/files/Guidelines/AHRI%20Guideline%20K-2009.pdf

Air-Conditioning, Heating, and Refrigeration Institute (AHRI). 2012. *2012 Guideline for Assignment of Refrigerant Container Colors*. Available at:

http://www.ahrinet.org/App_Content/ahri/files/Guidelines/AHRI%20Guideline%20N-2012.pdf

Climate Action Reserve. 2013a. Project Database. Available at:

<https://thereserve2.apx.com/myModule/rpt/myrpt.asp?r=111>.

Climate Action Reserve. 2013b. Frequently Asked Questions: Accounts on the Reserve. Available at:

<http://www.climateactionreserve.org/resources/faqs/>.

Climate Action Reserve. 2013c. Submit and Register a Project. Available at:

<http://www.climateactionreserve.org/how/projects/register/>.

Climate Action Reserve. 2012. *Article 5 ODS Project Protocol, Version 2.0*. June 27, 2012. Available at:

http://www.climateactionreserve.org/wp-content/uploads/2010/02/A5_ODS_Project_Protocol_V2.0_Package_041113.pdf.

Ecosystem Marketplace. 2013. *Maneuvering the Mosaic: State of the Voluntary Carbon Markets 2013*.

ICF International. 2009. *ODS Destruction in the United States of America and Beyond*, prepared by ICF International for the U.S. Environmental Protection Agency. May 2009. Available at:

http://ozone.unep.org/Data_Reporting/USA-Decision-XX-7-ODS-Destruction.pdf.

ICF International. 2010. *Study on Financing the Destruction of Unwanted Ozone-Depleting Substances through the Voluntary Carbon Market*, prepared by ICF International for the World Bank. February 2012.

Ministry of Environment, Indonesia (MoE). 2013. *Visit to Holcim ODS Destruction Facility in Indonesia*. Presentation prepared for Australia network meeting, May 2013.

Multilateral Fund (MLF). 2009. *Study on Financing the Destruction of Unwanted Ozone-Depleting Substances through the Voluntary Carbon Market, Draft Report*. Prepared by ICF International for the World Bank. September 2009. Available at:

<http://www.multilateralfund.org/sites/59/Document%20Library2/1/59Inf2.pdf>.

National Council on Climate Change (NCCC) of Indonesia. 2013a. *Market Readiness Proposal: Indonesia*.

Available at: <http://www.thepmr.org/system/files/documents/Indonesia%20MRP%20Final-September29.pdf>.

National Council on Climate Change (NCCC) of Indonesia. 2013b. *Nusantara Carbon Scheme*. Available at: http://www.iges.or.jp/en/archive/cdm/pdf/regional/20130306/4_Indonesia_Mr.Dicky.pdf.

Partnership for Market Readiness. 2013. *Pricing Carbon and Shaping the Next Generation of Carbon Markets*. Available at: https://www.thepmr.org/system/files/documents/PMR_brochure_web.pdf.

Partnership for Market Readiness. 2013. *Indonesia*. Available at: <http://www.thepmr.org/country/indonesia-0>. Accessed October 14, 2013.

Partnership for Market Readiness. 2013. *Chairs' Summary of the Sixth Meeting of the PMR Partnership Assembly (PA6)*. May 27-28, 2013. Available at: https://www.thepmr.org/system/files/documents/PA6_Chair's_Summary_0.pdf.

Pasek, Ari Darmawan. 2013. *Inventory of Unwanted ODS in Indonesia*. Report submitted to the World Bank and ICF International on January 13, 2014.

Statistics Indonesia. 2009. The 2010 Indonesia Population Census. Available at: http://unstats.un.org/unsd/censuskb20/Attachments/2009IDN_ISI-GUIDfba441dd463e4ca5907f1a1ae508f3ff.pdf.

Technology and Economic Assessment Panel (TEAP). 2002. *Report of the Task Force on Destruction Technologies*. April 2002. Available at: http://ozone.unep.org/Assessment_Panels/TEAP/Reports/Other_Task_Force/TEAP02V3b.pdf.

United Nations Environment Programme (UNEP). 2013. *Report on Progress and Experiences gained in Demonstration Projects for the Disposal of Unwanted ODS*. UNEP/OzL.Pro/ExCom/70/54. June 5, 2013.

United Nations Environment Programme (UNEP). 2012a. *Project Proposals: Turkey*. UNEP/OzL.Pro/ExCom/66/48. March 19, 2012.

United Nations Environment Programme (UNEP). 2012b. *Project Proposals: Nigeria*. UNEP/OzL.Pro/ExCom/67/27. June 19, 2012.

United Nations Environment Programme (UNEP). 2011. *Project Proposals: Mexico*. UNEP/OzL.Pro/ExCom/63/42. March 9, 2011.

Verified Carbon Standard (VCS). 2013. *Program Fee Schedule, Version 3.4*. Available at: <http://www.v-c-s.org/sites/v-c-s.org/files/Program%20Fee%20Schedule%2C%20v3.4.pdf>.

Verified Carbon Standard (VCS). 2011. *Recovery and Destruction of ODS from Products, Methodology VM0016, Version 1.0*. Available at: <http://www.v-c-s.org/sites/v-c-s.org/files/Final%20version%20of%20VM0016.pdf>.

Appendix A. Workbook on the Management of Unwanted ODS in Indonesia

Table of Contents

1. Introduction to the Workbook	2
2. Policy and Regulatory Context	2
2.1. International Agreements Governing the Movement of ODS.....	2
2.2. Regional Agreements and National Regulations	4
3. National Inventory of Unwanted ODS	4
4. Guidelines for Managing Unwanted ODS	6
4.1. Collection of ODS.....	7
4.2. Consolidation and Storage.....	7
4.3. Transportation	7
4.4. Testing	8
4.5. Destruction	9
5. Project Development	9
5.1. Assessing the Financial Feasibility of an ODS Destruction Project.....	9
5.2. Selecting a Strategy for Project Development	11
5.3. Overview of the Project Development Process.....	12

_Toc371075838

1. Introduction to the Workbook

The Montreal Protocol on Substances that Deplete the Ozone Layer has been immensely effective at reducing the production and consumption of ozone depleting substances (ODS) worldwide. While the production and consumption of ODS has dramatically diminished, a large amount of ODS still remains in equipment, products, and stockpiles held by country governments as well as industrial and commercial users. Because emissions from ODS banks are not explicitly controlled by the Montreal Protocol, there is significant risk that these ODS will be released to the atmosphere, contributing to both ozone depletion and global climate change.

To prevent emissions of ODS banks, many options have been explored to provide incentives for the destruction of unwanted material. The high global warming potential (GWP) of ODS means that their destruction has the ability to generate significant volumes of carbon credits. Indeed, a study prepared for the World Bank in 2010 found that a significant opportunity exists for financing the destruction of ODS through the voluntary carbon market.⁴ To help countries operating under Article 5(1) of the Montreal Protocol take advantage of this opportunity, this workbook was developed to serve as a general guide on how to manage unwanted ODS held by country governments.

Specifically, this workbook begins with a summary of international agreements and local regulations that govern the movement of ODS; then provides guidance on how to develop an inventory of unwanted ODS; followed by a description of guidelines for proper handling of unwanted ODS; and finally provides an overview of the project assessment and development process, including strategies for engaging the public and/or private sector in an ODS destruction project. This version of the workbook has been tailored to reflect specific circumstances for Indonesia.

2. Policy and Regulatory Context

2.1. International Agreements Governing the Movement of ODS

There are several international agreements that affect the movement of unwanted ODS between countries. These include the Basel Convention on the Control of Transboundary Movements of Hazardous Wastes and Their Disposal, and the OECD Decision C(2001)107/Final on the Control of Transboundary Movement of Wastes Destined for Recovery Operations. The basic provisions of these agreements are described below.

The Basel Convention

Adopted in 1989 and brought into force in 1992, the Basel Convention on the Control of Transboundary Movements of Hazardous Wastes and Their Disposal (the Basel Convention) was created to control the

⁴ ICF International. 2010. *Study on Financing the Destruction of Unwanted Ozone-Depleting Substances through the Voluntary Carbon Market*, prepared by ICF International for the World Bank. February 2012.

movement of hazardous waste between countries, particularly the transfer of hazardous waste from developed to developing countries.⁵ Currently there are 180 Parties to the Convention.⁶

Under the Basel Convention, ODS are included in the definition of hazardous waste.⁷ As a result, any transboundary movement of unwanted ODS for the purpose of destruction must comply with provisions of the Convention. These provisions prohibit the shipment of hazardous wastes between Parties without prior written consent from the proposed State of import. In addition, Parties may only transport hazardous waste to/from non-party countries⁸ if they have entered into a bilateral, multilateral, or regional agreement that provides for procedures that are as environmentally-sound as those provided under the Convention.⁹

Parties to the Basel Convention must also ensure that hazardous and other wastes are managed and disposed of in an environmentally-sound manner. To achieve this goal, Parties must minimize the movement of hazardous waste across borders. Parties may only move hazardous wastes across borders if the State exporting hazardous waste lacks the necessary facilities, capacity, or suitable disposal sites to dispose the waste in an environmentally sound and efficient manner.

The OECD Decision C(2001)107/Final

In 2001, the Organisation for Economic Co-operation and Development (OECD) decided to regulate the international movement of wastes through decision C(2001)107/Final. Under this OECD decision, member countries can control transboundary movements of wastes destined for recovery operations, and recovery facilities must recover wastes in an environmentally-sound manner, in accordance with national regulations. CFCs and halons are subject to the Amber control procedure, which requires strict documentation for transboundary movement of wastes throughout the entire process, starting with the exporter and ending with the recovery facility. When transboundary movement or recovery operations cannot be completed as planned, the exporter or importer must provide financial guarantees for the environmentally-sound management of the wastes.¹⁰

⁵ The Basel Convention on the Control of Transboundary Movements of Hazardous Wastes and their Disposal, Texts and Annexes, *available at* <http://www.basel.int/Portals/4/Basel%20Convention/docs/text/BaselConventionText-e.pdf>.

⁶ Secretariat of the Basel Convention (2013), Parties to the Basel Convention, accessed June 2013, *available at* <http://www.basel.int/Countries/StatusofRatifications/PartiesSignatories/tabid/1290/Default.aspx>.

⁷ ODS fall under the Convention's categories Y41 (Halogenated organic solvents) and Y45 (Organohalogen compounds other than substances referred to in the Annex).

⁸ Non-party countries include: Angola, Fiji, Grenada, Haiti, Myanmar, Sao Tome and Principe, Sierra Leone, Solomon Islands, South Sudan, Timor-Leste, Tuvalu, United States, and Vanuatu. Source: <http://www.basel.int/Countries/StatusofRatifications/PartiesSignatories/tabid/1290/Default.aspx>.

⁹ Multilateral Fund (2006), Report of the Meeting of Experts to Assess the Extent of Current and Future Requirements for the Collection and Disposition of Non-Reusable and Unwanted ODS in Article 5 Countries (Follow up to Decision 47/52). 20 March 2006.

¹⁰ OECD, Decision of the Council concerning the Transboundary Movements of Wastes Destined for Recovery Operations, C(2001)107/FINAL, June 2001, *available at* <http://acts.oecd.org/Instruments/ShowInstrumentView.aspx?InstrumentID=221&InstrumentPID=217&Lang=en&Book=False>.

2.2. Regional Agreements and National Regulations

In addition to the international agreements described above, regional agreements and national regulations govern the movement of ODS. As a signatory of the Montreal Protocol, Indonesia has developed a number of domestic policies to monitor and limit consumption of ODS to meet ODS phase-out targets that are established by the Parties to the Montreal Protocol. Of note, in 1998, Indonesia first banned the production and import of certain ODS, including carbon tetrachloride, halon, and methyl chloroform (Minister of Industry and Trade No. 110/MPP/Kep/1/1998). In 2006, the import of CFCs, R-500, R-502, and methyl bromide (except in quarantine and pre-shipment applications) were also banned (Minister of Trade No. 24/M-DAG/PER/6/2006). In 2007, a further ban on the use of CFCs, R-500, and R-502 in the manufacture of new products was adopted, effective July 1, 2008 (Minister of Industry No. 33/M-IND/PER/4/2007).

According to Indonesian law, all CFCs, halons, and methyl bromide are classified as hazardous substances. As such, national law requires that stocks be managed in accordance with hazardous waste regulations (Government Regulation No. 18/1999 and Government Regulation No. 74/2001). In turn, government approval is required for the export of unwanted ODS.

For ODS that have not yet been banned (i.e., HCFCs), when imported into the country these chemicals are subject to a number of regulatory checks (Minister of Trade No. 03/M-DAG/PER/1/2012). Specifically, permits are required for the import of HCFCs. Additionally, shipments must pass through one of seven designated entry points in the country, and refrigerant identifiers are used to verify the contents of the import.

3. National Inventory of Unwanted ODS

Banks of unwanted ODS commonly reside in stockpiles and retired equipment that are largely owned or in the possession of government agencies and private companies. As a first step to managing these banks, an inventory detailing the quantity, type, purity, location, and ownership of the material must be developed. This inventory can be developed through a variety of actions, including compilation of records from Customs and/or other government agencies as well as by conducting an assessment of stockpiled material through site visits to storage facilities. The installed base of equipment containing ODS may also be compiled through input from end-users and industry. The approach used will depend on the quality and robustness of data tracking systems that are already in place in Indonesia.

When compiling the information, unwanted ODS in stockpiles and in equipment should be inventoried separately. For ODS in equipment, Indonesia may wish to focus on inventorying equipment with larger ODS charge sizes, such as chillers, which often present more cost-effective opportunities for destruction.

Eligibility

While only CFCs and other phased-out ODS are currently eligible under ODS destruction protocols in the voluntary carbon market, it is expected that the destruction of next-generation refrigerants such as HCFCs (and HFCs) will eventually be eligible for carbon credits, and thus inventorying all substances can support future projects.

To assist in the development of an ODS inventory, an Excel-based inventory tool may be used, as provided as an attachment to this workbook. The tool should be populated following an assessment of the stockpiles and equipment that reside in your country. Guidance for how to populate the tool is provided below along with example screenshots from the inventory tool:

- ❖ **Stockpiles:** For each cylinder, fill out one row indicating the serial number, manufacturer, location, and size of the cylinder, as well as the type(s) of chemicals contained, including CFCs, HCFCs, and HFCs. If multiple chemicals are mixed in cylinder, specify each type of chemical, if possible. Other data elements may also be collected, such as the tare weight of the cylinder and the total weight of the cylinder, including its contents.

Stockpile Inventory

Instructions: For each cylinder, fill out one row indicating the serial number and manufacturer of the cylinder, the location (facility name, street address, and city), the size of the cylinder (in kilograms), and the type(s) of chemicals contained, including CFCs, HCFCs, and HFCs. If multiple chemicals are mixed in cylinder, please indicate each type.

Stockpile ID #	Cylinder Serial Number	Cylinder Manufacturer	Facility Name	Street Address	City	Cylinder Size (kilograms)	Chemical Type
S1							
S2							
S3							
S4							
S5							
S6							
S7							
S8							
S9							

- ❖ **Chillers:** For each chiller, fill out one row indicating the location of the chiller, the chiller type, the cooling capacity, the type of refrigerant contained (including CFCs, CTC, methyl chloroform, HCFCs, HFCs), and the refrigerant charge size.

Chiller Inventory

Instructions: For each chiller, fill out one row indicating the location of the chiller (facility name, street address, and city), the chiller type (reciprocating, scroll, screw, or centrifugal), the cooling capacity (in tons), the type of refrigerant contained (including CFCs, HCFCs, and HFCs), and the refrigerant charge size (in kilograms).

Chiller ID #	Name of Facility Holding Chiller	Street Address	City	Chiller Type	Cooling Capacity (Tons)	Refrigerant Type	Refrigerant Charge Size (Kilograms)
C1							
C2							
C3							
C4							
C5							
C6							
C7							
C8							
C9							

- ❖ **Other Equipment:** For each piece of equipment, fill out one row indicating the location of the equipment, the equipment type (e.g., dehumidifier, refrigerator/freezer), the type of refrigerant contained (including CFCs, HCFCs, and HFCs), the refrigerant charge size, the substance in foam (including CFCs, HCFCs, and HFCs), if applicable, and the mass of the substance in foam.

Other Equipment Inventory

Instructions: For each piece of equipment, fill out one row indicating the location of the equipment, the equipment type (e.g., dehumidifier, refrigerator/freezer), the type of refrigerant contained (including CFCs, HCFCs, and HFCs), the refrigerant charge size, the substance in foam (including CFCs, HCFCs, and HFCs), and the mass of the substance in foam.

Equipment ID #	Name of Facility Holding Equipment	Street Address	City	Equipment Type	Refrigerant Type	Refrigerant Charge Size (Kg)	Substance in foam	Mass of Substance in Foam (Kg)
E1								
E2								
E3								
E4								
E5								
E6								
E7								
E8								
E9								

Once the inventory tool is populated, the summary tables will auto-complete, showing total quantities of unwanted ODS held domestically to enable further analysis about the financial feasibility of destruction projects.

Inventory Summary

Inventory Type	Stockpile Inventory (kg)	Stockpile Inventory (MTCO2e)	Chiller Inventory (kg)	Chiller Inventory (MTCO2e)	Other Equipment Inventory (kg)	Other Equipment Inventory (MTCO2e)
CFC-11						
CFC-12						
CFC-114						
HCFC-22						
HCFC-123						
HCFC-124						
HCFC-141b						

4. Guidelines for Managing ODS

The general process toward ODS destruction involves collection, consolidation and storage, transport, testing, and final disposal, as illustrated in the figure to the right. In each step of this process, best practices for handling unwanted ODS must be followed to ensure eligibility for carbon offsets under existing carbon markets. Currently, two major platforms in the voluntary carbon market are crediting for ODS destruction projects: the Climate Action Reserve (the Reserve) and the Verified Carbon Standard (VCS).¹¹ Since Indonesia is also in the process of developing a national carbon market that could allow for crediting for ODS destruction projects, requirements that are specific to their national offset program, once fully developed, will also need to be considered. A description of the requirements identified in the Reserve and VCS methodologies is provided below. Note that it is anticipated that these requirements will be similar to those required of the anticipated national program.

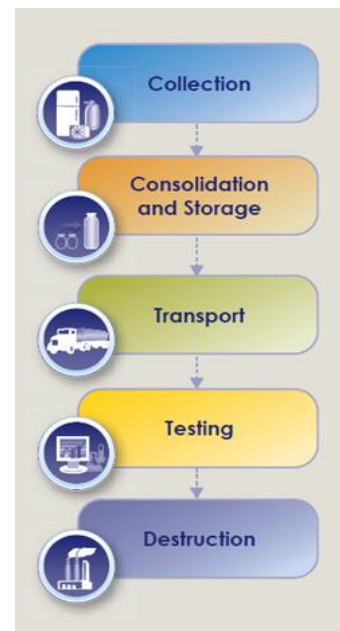

¹¹ The Reserve’s Article 5 ODS Project Protocol; Approved VCS Methodology VM0016: Recovery and Destruction of ODS from Products

4.1. Collection of ODS

As previously discussed, unwanted ODS is most commonly found in stockpiles and decommissioned equipment. Guidelines to follow when collecting this material include:

- ❖ ODS should be collected, stored, and transported in cylinders or other hermetically sealed containers.
- ❖ Removal of refrigerant from commercial/industrial equipment at end-of-life should be conducted on site by certified technicians. Refrigerator cabinets may be shredded whole and steam-treated in an airtight chamber to recover ODS blowing agents or the foam may be removed and treated separately.

Custody and Ownership

Throughout the entire process, it is critical to properly document the chain of custody. Carbon credits will not be issued unless ODS ownership can be properly established; therefore, all records that show previous ownership of the material and transfer of that ownership to the project developer should be maintained. For VCS, the chain of custody must be documented by paper bills of lading or electronic, third-party tracking that includes proof of delivery. Other forms of documentation are accepted by the Reserve, including purchase orders or agreements, packing lists, lab test results, transfer container information, receiving inspections, freight bills, transactional payment information, or other supporting information.

- ❖ The point of origin and date of establishment must be documented for each quantity of ODS. For stockpiles, the point of origin is the location of the stockpile.¹² For ODS recovered from equipment at end-of-life, the point of origin is the location where the ODS was recovered from the equipment. Records should be kept including the facility name, address, and serial or ID number of the containers used for storage and transport.

4.2. Consolidation and Storage

Because ODS might be collected from a large number of smaller units (such as household refrigerators or small cylinders), it needs to be combined before sending it for destruction; this step avoids the shipping of many smaller containers, which can lead to additional expense, possible damage and leakage, and other obstacles. Collected ODS is typically brought to a central facility, where it is consolidated into larger cylinders or storage tanks, and stored until a quantity sufficient for destruction has been aggregated.

4.3. Transportation

In this step, the ODS is transported to a destruction facility by truck, rail, or ship. The ODS may be transported several times before its ultimate destruction, often as it moves through the consolidation process.

¹² The date on which a quantity of ODS was “stockpiled” is defined by the Reserve as the furthest date in the past on which the quantity of ODS contained in the reservoir was greater than or equal to the total quantity of all ODS removed from the reservoir since that date.

Per the Code of Good Housekeeping approved by the Montreal Protocol, to ensure that ODS does not constitute an unnecessary risk in transportation, shipments must be properly packaged and labeled. Instructions to be followed in the event of danger or accident must accompany each shipment to protect human beings and the environment from any danger that might arise during the operation. Notification of the following information should be provided at any intermediate stage of the shipment from the place of dispatch until its final destination: (a) the source and composition of the ODS and products containing ODS, including the customer's identity; (b) arrangements for routing and for insurance against damage to third parties; (c) measures to be taken to ensure safe transport and, in particular, compliance by the carrier with the conditions laid down for transport by the States concerned; (d) the identity of the consignee, who should possess an authorized centre with adequate technical capacity for the destruction; and (e) the existence of a contractual agreement with the consignee concerning the destruction of ODS and products containing ODS.

To remain eligible for carbon credits, all import activities must be conducted in full compliance with all Indonesian regulations, and must have a complete import record. Under the Reserve, ODS must be imported into the United States for destruction, and full documentation of this process, including all petition and record-keeping documents, must be retained and provided for verification.

4.4. Testing

After arrival at the destruction facility, but before the material is destroyed, testing of the container contents is undertaken to verify exactly what materials are being destroyed, often through gas chromatography. The Reserve and VCS have similar methodologies that must be followed for determining the precise mass and composition of ODS to be destroyed, as briefly described below. Responsibility for following these methodologies is generally borne by the project developer.

First, the mass must be determined. Specific requirements for measuring the weight of the container can be found in each methodology. Second, the composition and concentration of ODS and contaminants must be established for each individual container. A sample from each container of ODS must be analyzed for composition and concentration at a lab accredited to perform analyses in compliance with the applicable International Organization for Standardization (ISO) standard or at an Air-Conditioning, Heating and Refrigeration Institute (AHRI) certified laboratory using the AHRI 700-2006 standard. The laboratory performing the composition analysis must not be affiliated with the project developer or the project. Specific requirements must be met for each sample, as described in detail in the methodologies, and analysis of the samples should provide:

1. Identification of the refrigerant;
2. Purity (%) of the ODS mixture by weight using gas chromatography;
3. Moisture level in parts per million. The moisture content of each sample must be less than 75% of the saturation point for the ODS based on the temperature recorded at the time the sample was taken;
4. Analysis of high boiling residue, which must be less than 10% by mass; and

5. Analysis of other ODS in the case of mixtures of ODS, and their percentage by mass.

For containers holding mixed ODS, a separate process must be followed. This process includes determination of the composition and concentration of ODS on a mass basis, followed by circulation of the mixed ODS and then sampling and analysis.

4.5. Destruction

For both the Reserve and VCS, destruction of ODS must occur at a facility that meets all guidelines provided in the UNEP Technology and Economic Assessment Panel (TEAP) Task Force on Destruction Technologies. In addition, under the Reserve, destruction facilities must be located in the United States and meet requirements of U.S. domestic law.

How long does an ODS destruction project take?

Once the project has been identified, it can take from about one year to several years from project development through to sale of the credits. The timeframe depends on a variety of factors including the complexity of the project, the type or design of the project (e.g., some projects are designed to be implemented over several years, such as an on-going refrigerator collection program), and many other factors, some of which can be influenced by the project developer and some which cannot.

While destroying ODS material, operating parameters of the destruction unit must be monitored and recorded in accordance with each of the methodologies and the Code of Good Housekeeping approved by the Montreal Protocol. Like for testing, responsibility for following these methodologies is generally borne by the project developer.

5. Project Development

Because the Kyoto Protocol limits trading to non-Montreal Protocol greenhouse gases, ODS are currently not eligible for projects under the Clean Development Mechanism. Instead, ODS destruction is eligible to earn carbon credits in the voluntary carbon market, where organizations can offset carbon emissions on a voluntary basis. In the voluntary carbon market, two major third-party standards are offering credits for ODS destruction projects: the Verified Carbon Standard (VCS) and the Climate Action Reserve (the Reserve).¹³ In Indonesia, a national carbon market may also eventually allow for credits from ODS destruction projects to fulfill national requirements.

The sections below describe considerations for assessing the financial feasibility of an ODS destruction process and for engaging with the private sector for project development, followed by an overview of the general project development process.

5.1. Assessing the Financial Feasibility of an ODS Destruction Project

Before initiating the project development process, a preliminary assessment of the cost-effectiveness of the project should be considered.

¹³ While technically there is no strict requirement to operate in accordance with a third-party standard, end consumer requirements are driving demand for projects developed using recognized third party standards. In 2008, 96 percent of transacted VERs was verified by a third-party standard.

The overall cost of developing an ODS destruction project includes the costs of collection, transportation, storage, testing, and destruction, as well as the “transaction” costs of project preparation, validation, and verification.¹⁴ Project costs vary widely depending on many factors such as geographical location, nature of ODS bank and the effort required to recover the ODS, quantity of ODS being handled, technologies used, type of ODS, firms contracted, and demand for services. In general, some projects may be more costly than others to develop. For example, collecting used CFCs from household refrigerators is likely to be more costly than recovering ODS from commercial air conditioning equipment with large charge sizes, on a per kilogram of ODS basis. Destroying existing ODS stockpiles may be the most cost-effective project type.

What are some strategies to minimize costs?

- Combine ODS destruction projects with other activities or programs that are also eligible for crediting in the carbon market, such as equipment replacement for energy efficiency credits. This strategy could be effective to fund ongoing collection programs, such as municipal, utility, or retailer programs to collect refrigerators on disposal, and ensure that ODS refrigerant and foam blowing agent is destroyed.
- Mainstream ODS destruction projects into larger programs and development projects, such as country ODS phaseout programs or a comprehensive waste management program.
- Group or pool projects to minimize transaction costs and achieve economies of scale.

Because some project costs are “fixed” (i.e., they do not vary depending on the amount of ODS destroyed), destroying larger volumes of ODS can lead to higher profitability. In particular, project transaction costs—such as the cost of project preparation, verification, etc.—must be incurred regardless of the amount of ODS destroyed. Additionally, some project implementation costs may also be realized irrespective of the amount of ODS collected and destroyed. For example, setting up the infrastructure for a refrigerator collection program may be a one-time cost that does not depend heavily on the number of refrigerators collected. These “fixed” costs mean that in some cases there may be a minimum amount of ODS that must be destroyed in order to have a financially viable project.

The profitability of the project will also strongly depend on the trading price of carbon credits verified by each third-party standard, and the attractiveness of ODS destruction credits to buyers. Demand in the voluntary market is driven not by regulation but by buyers’ interest in mitigating and offsetting their emissions—which is often motivated by reputational considerations. As such, ODS projects need to be packaged in a way that is attractive to buyers and their stakeholders. In particular, ODS project proponents may need to differentiate themselves from other industrial gas projects that have drawn criticism (and lower carbon prices) in the past, such as HFC-23 destruction. A good solution here is for ODS destruction projects to tell a compelling story emphasizing that they help pay for the removal of GHGs that would otherwise be emitted over time if left unaddressed.

From the sellers’ side of the market, uncertainty about carbon prices will be an ongoing challenge that is inherent to the carbon market. Prices depend on a variety of factors, including the standard to which the project is developed, the perceived robustness of the methodology used, and so on. In the past, low

¹⁴ Most of these costs are likely to be borne by the project developer (or the project financier), although some upfront costs—such as those to maintain ODS stockpiles in advance of project development—are usually borne by the owner of the ODS.

prices on the Chicago Climate Exchange (CCX) market have contributed to decisions not to move forward with an ODS destruction project, such as in the case of Argentina, where some CTC was instead sold to Mexico for feedstock use rather than destroyed in the U.S. for crediting under CCX. If project developers are uncertain about whether a project will earn a profit, it may not be pursued. Prices for the over-the-counter market are not generally disclosed publicly but are available indirectly through several sources, including an annual report published by Ecosystem Marketplace and New Carbon Finance (available on www.ecosystemmarketplace.com).

5.2. Selecting a Strategy for Project Development

Once the decision is made to pursue an ODS destruction project, several options for structuring private-public financing arrangements are available for government agencies in possession of unwanted ODS. These options include:

- ❖ **Contracting Out**—The process is managed by a private sector entity with the Government informing the public of potential revenue streams from ODS disposal and issuing appropriate documentation required for disposal or export for final disposal. Under this option, ownership of the ODS would be transferred to a private entity, who would then develop an ODS destruction project, and all project revenues would be owned by the private entity. That said, some revenues may still accrue to the Government, if, for example, a Government chose to sell its ODS stockpile via an auction process. This option has the lowest administrative and cost burden on the Government.
- ❖ **Facilitation**—The Government plays a modest administrative role and exercises its regulatory responsibilities while working in concert with a private sector project developer to facilitate the chain of identification, inventory development, collection, licensing, auctioning, registering and collecting/transferring revenues to the Government. Under this option, the Government would need to identify and hire a project developer to develop the project on its behalf, as well as negotiate ownership of the final credits earned. In some arrangements, ownership of these credits is fully transferred to the owner of the ODS; in other arrangements, ownership of the credits is shared between the project developer and owner of the ODS.
- ❖ **Project Developer**—In this option, a Government entity assumes responsibility for creating the emission reduction credits by managing and generating credit through the chain of activities identified above in order to generate and collect carbon revenues for the Government. This option has the highest administrative burden for the Government, and requires the Government entity to have significant capacity and experience in the voluntary carbon market, and to be able to cover upfront project development costs and market the credits, in anticipation of future revenues. While no rules restrict governments from acting as project developers, there is also no clear precedent for national government participation in the project development side of the voluntary market. Generally, government roles have tended to focus on facilitating market intervention through capacity building and legislation, although there is some experience with governments serving as the project developer and coordinating entity for a programme of

activities through CDM. If a national carbon trading system accommodates ODS destruction projects, however, the hurdle may be lower for Government entities serving in a project developer role.

Under the first two options identified above, the Government can rely on a private sector entity to guide it through the project development process, as described in the next section. To initiate this engagement, however, a Government must identify and contract with a private sector entity.

The procurement process to contract a project developer from the private sector must be undertaken in accordance with national rules and regulations but generally involves the preparation and release of a request for an Expression of Interest (EOI) to potential project developers; selection of a short-list of qualified candidates from those submitting EOIs; preparation and release a Terms of Reference (ToR) to the short-listed candidates; and selection and contract establishment with the chosen company. A list of potential project developers is provided in Appendix C. An example ToR is provided in Appendix D.

5.3. Overview of the Project Development Process

Whether led by a private sector project developer—or a Government entity acting as project developer—the development of a voluntary project generally follows a number of broad steps, as shown in the figure below. The broad steps that the project developer could take towards developing an ODS destruction voluntary project are subsequently described.

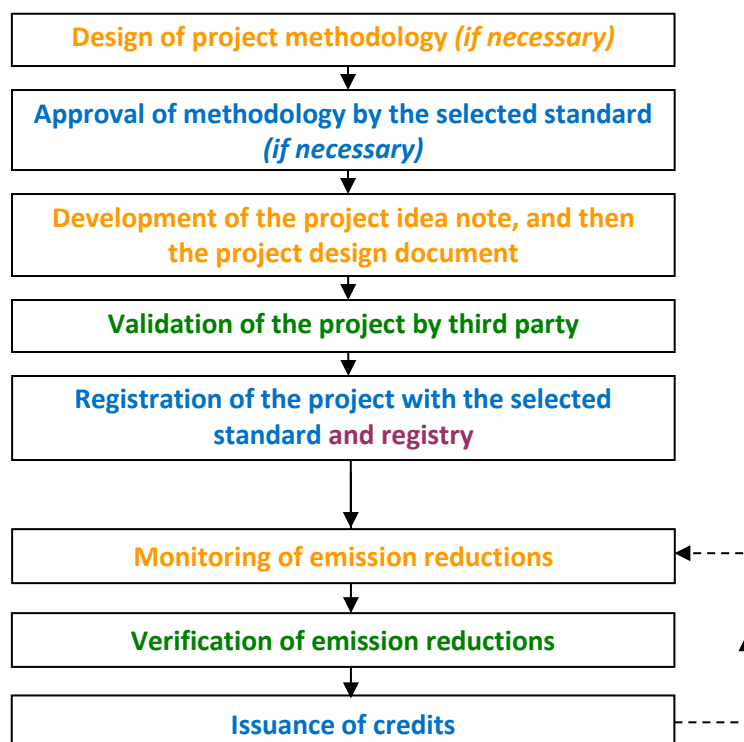

Developing a voluntary project involves a number of generic steps regardless of the specific standard being pursued. Different stakeholders specific to the project cycle are:

- **Project developer**
- **Verifier:** third party in charge of assessing compliance of the project with the rules of the standard pursued
- **Standard:** the specific authority that officially registers the project and issues credits
- **Registry:** a system for creating, tracking, trading and retiring carbon credits

1. Review voluntary market third-party standards and existing methodologies for selection.

A project developer would first review the available standards to identify which one meets the needs of the envisioned ODS destruction project (e.g., given the standard's rules, geographical coverage, and so on). For example, currently the Reserve limit eligible projects to those that destroy ODS in the United States; if national regulations make it difficult to move ODS transnationally, the Reserve may not be a viable option.

Currently, one protocol exists for ODS destruction under the Reserve (*Article 5 ODS Project Protocol Version 2.0*), and one exists under VCS (*VM0016*). If one of these methodologies is appropriate for the project in question (e.g., the envisioned project seems eligible under the methodology, the methodology seems "doable"), then the project developer can move on to the next step. If this is not the case, however, then the project developer generally has two options:

- ❖ Seek a revision or deviation to an existing methodology (if allowed), or
- ❖ Develop a new methodology for submission and approval by the third-party standard that is being pursued (if the standard accepts new methodologies).

If neither option is possible, then the project developer cannot move forward under the standard selected.

2. Develop a project idea note.

Once a methodology is selected (or approved), the project developer usually develops a project idea note (PIN). A PIN is not required by the third-party standards, but is often used to attract financing for a project. A PIN describes the project and sets out the business case for the voluntary credit project, as well as the additionality case. It sets out if an existing methodology is applicable to the project or whether a new methodology needs to be developed. It also presents the likely costs, expected number of credits the project would produce, the voluntary standard that would be sought, and the potential revenue that the sale of the credits could generate.

Depending on the level of in-house expertise, this, and other project documentation and support, may be undertaken by an external consultant.

3. Establish funding.

The project developer has two main options for financing:

- ❖ Fund the entire project activity itself with a view to selling the credits once the project is registered and the credits are issued or
- ❖ Use the PIN to attract interest from a financier. A financier could provide the capital required to support the project through the cycle and fund the destruction process in return for more favorable credit prices, or could support just the carbon costs of the project.

4. Develop full project documentation.

Once financing is in place, the full project documentation (i.e., the project design document or its equivalent, as defined by the third-party standard, describing the emission reduction activity) would be developed and the validation process would begin (if required).

5. Monitor and verify emission reductions, and receive credits.

Next is the annual monitoring and verification of emission reductions generated by the project by an external auditor. The project developer generally engages a third-party verifier to certify the validity of the project's emissions reductions. Upon receipt of a completed verification report, the selected registry issues the credits.

6. Obtain validation.

If required by the third-party standard, the project documentation is also submitted for validation. If successful, the project is then registered under the selected standard. This step is not required for the Reserve.

7. Market the credits.

Depending on the arrangements with the financier, the credits would pass to the owner, or be shared between the owner and the developer, as negotiated. Project developers may then sell offsets through brokers to aggregators or final customers (e.g., companies or consumers looking to voluntarily offset their emissions). Developers may also sell to aggregators directly or onto an exchange.

Verification Process

Verification of emission reductions is a critical step in the project development process that includes the following:

- Testing Internal Controls
- Conducting Substantive Testing
- Data Validation
- Aberrant Data
- Reasonable Assumptions, Methodologies, and Calculations

As such, this process should be undertaken by a credible third-party to ensure validation.

Appendix B. Importance of Evaluation Criteria Relative to Financing Options

Evaluation Criteria	Importance for the Viability of Financing Options		
	National Carbon Market	VCS	The Reserve
Required Criteria			
National carbon market has been established or is under development	Required	NA	NA
No national capacity for ODS destruction exists AND there are no national regulations currently in place that hinder the export of ODS	Required	Required	NA
The anticipated market price of the ODS destruction credits will be high enough to cover projected project costs	NA	Required	Required
There are no national regulations currently in place that hinder the export of ODS	NA	NA	Required
Preferred Criteria			
The country is a participant in PMR Program	Highly Preferred	NA	NA
National capacity for ODS destruction exists	Highly Preferred	Preferred	NA
Regional capacity for ODS destruction exists	Preferred	Highly Preferred	NA
Regional or national capacity for ODS destruction has a removal efficiency of at least 99.9999 percent	NA	Highly Preferred	NA
Project developers have shown interest in developing an ODS destruction project with the material sourced from Indonesia	Preferred	Highly Preferred	Highly Preferred

Appendix C. Potential Project Developers

The following list of project developers identifies companies that either have direct experience developing ODS destruction projects or have other relevant experience developing regional projects under the Reserve and/or VCS. While not an exhaustive list, the following companies are considered to be the most likely to undertake development of an A5 ODS destruction project for Indonesia.

A-Gas RemTec
1100 Haskins Road
Bowling Green, OH 43402 USA
1-800-372-1301

EOS Climate Inc.
55 Hawthorne St, Suite 610
San Francisco, CA 94105 USA
800-764-8093
info@eosclimate.com

COOLGAS, INC.
30045 FM 2978
Magnolia, TX 77354 USA
1-800-366-1356

OEKO Service Luxembourg (O.S.L.) S.A.
Zone Industrielle Piret, B.P. 43
7737 Colmar-Berg, Luxembourg
+352488216-1

Diversified Pure Chem, LLC
11050 South Highway 287
Rhome, TX 76078
817-636-2089
sales@divpc.com

RapRec Refrigerants
8971 W. Bloomfield Rd.
Peoria, AZ 85381
877-372-7732

Emergent Ventures India (EVI)
5th Floor, Universal Trade Tower
Gurgaon- Sohna Road, Sector 49
Haryana, India, 122018
+91-124-6653100
contact@emergent-ventures.com

Refrigerant Exchange Corp.
5263 N. 4th St.
Irwindale, CA USA
626-338-1890
info@refex.com

Environmental Credit Corp.
210 W. Hamilton Ave #297
State College, PA 16801 USA
607-288-4020
info@envcc.com

South Pole Carbon
2/22 Iyara Building, 6th Floor
Chan Road, Soi 2, Thungwatdorn
Sathorn, Bangkok 10120 Thailand
+ 66 2 678 89 79
info@southpolecarbon.com

Appendix D. Sample Terms of Reference for Project Developer



UNITED NATIONS INDUSTRIAL DEVELOPMENT ORGANIZATION

**DEMONSTRATION PROJECT FOR DISPOSAL
OF UNWANTED ODS IN MEXICO (MP/MEX/11/003 and TE/MEX/12/004)**

TERMS OF REFERENCE

***FOR THE SUPPLY OF SERVICES REQUIRED FOR THE DESTRUCTION OF
UNWANTED ODS COLLECTED IN MEXICO***

11th March 2013

I. GENERAL BACKGROUND AND OBJECTIVES

The 63rd Meeting of the Executive Committee of the Multilateral Fund for the Implementation of the Montreal Protocol (4 – 8 April 2011) approved funding for the demonstration project on ODS destruction in line with decision 58/19, to be implemented by UNIDO and the Government of France.

The objective of this project is to destroy 166.7 metric tons of unwanted ODS in the refrigeration sector in Mexico collected during the past 8 years: it includes all categories of activities for the disposal of ODS, namely transport, storage and destruction.

The estimated project impact reflects a total reduction of greenhouse gas emission of 997,110 tons of CO₂-equivalents.

Since 2005 the Government of Mexico through the Ministry of Energy and Energy Saving Fund (FIDE) has successfully accelerated the replacement of old refrigeration appliances with new energy efficient equipment. In 2007, the Secretariat of Environment and Natural Resources (SEMARNAT) and UNIDO, throughout the National CFC Phase out Plan, trained and equipped 100 collecting Centers (FIDE centers) with tools to identify and recover refrigerants gases from old appliances dismantled in these centers. In 2009, FIDE established the second phase of the program for the substitution of domestic refrigerators with the goal to replace and collect 1,600,000 appliances until the end of 2012; the new phase includes 110 collecting centers.

On the other hand, in 2007 SEMARNAT and UNIDO installed a network of 14 recycling centers within Mexico in order to provide recovery, recycling and storage for destruction services to the refrigeration technicians and companies involved in the refrigeration sector.

As of February 2013, the currently available stocks for destruction come from these two collection programs. Additionally, two pharmaceutical companies have remaining stocks of virgin CFC ready to send for destruction.

II. OFFER REQUIREMENTS

This Terms of Reference should be used for the preparation of a proposal to supply services required for the collection, transport and destruction of 74.1 tons of unwanted ODS.

The destruction of unwanted ODS must be carried out in compliance with the technologies approved by the Technology and Economic Assessment Panel of Montreal Protocol (TEAP - *Report of the Task Force on Destruction Technologies*; http://ozone.unep.org/teap/Reports/Other_Task_Force/index.shtml) and meet the performance parameters and emissions requirements set out by TEAP, as well as comply with the applicable local regulations.

The contract awarded company is required to carry out the transport for collection in order to consolidate all the quantities of ODS in one collection center which has to have all the permits for the management of this type of gases, including, but not limited to, hazardous waste management, in enough quantities to handle at least 74.1 tons.

If the destruction of ODS will take place outside Mexico, the collection center selected by the awarded company will be responsible for all export procedures, including licenses, allowances, and permits to export the referred ODS.

The collection and destruction of 74.1 tons of unwanted ODS has to be undertaken within one year starting from the date of signature of the contract related to these Terms of Reference. Companies must provide a detailed description of the destruction methods they will apply.

If unwanted ODS are to be destroyed in order to obtain Carbon Credits, destruction has to be carried out through methodologies approved by the Climate Action Reserve (CAR) or the Verified Carbon Standard (VCS). The methodologies taken into consideration must have been approved before the date of publication of the present Terms of Reference on the UNIDO website.

A. Technical Offer

The proposal of destruction services offered must include the following information:

1. General data of the company:
 - Name of the company
 - Address
 - Telephone
 - E- Mail

- web site (if available)
 - Operation records of the company for the last 2 years, demonstrating the experience in the management and destruction of refrigerant gases and/or comparable substances.
 - Listing of qualifications and brief description of experience of the personnel to be assigned to the project.
2. Detailed description of the destruction facility:
- Type of ODS destruction technology approved by TEAP.
 - Location of the facility.
 - Operational procedures.
 - ODS handling and storage including safety procedures for containers and bulk storage tanks for refrigerants.
 - ODS identification and quantification methods applied.
 - Preparation and feeding of gas to the destruction process.
 - Feed rate range (kg/hr) of gas.
 - Emission monitoring system.
 - Treatment of gaseous and aqueous effluents (when applicable).
3. Emission values of the destruction technology:
- Destruction and Removal Efficiency of ODS.
 - Emissions of dioxins and furans.
 - Emissions of acidic gases (HCl and HF), particles and carbon monoxide.
 - Emissions of metals and other relevant pollutants.
4. Information of the Collection Center:
- Name of the Center
 - Address
 - Telephone
 - E- Mail
 - web site (if available)
 - Number of hazardous waste collection registry delivered by SEMARNAT.
 - Number of all environmental authorizations required to get the export permission of recovered ODS.
 - Operation records demonstrating the experience in the management of refrigerant gases and/or comparable substances.
 - Listing of qualifications and brief description of experience of the personnel to be assigned to the project.
5. Information on the Transport Company for the transport of recovered ODS:
- Name of the Transport Company
 - Address
 - Telephone
 - E- Mail
 - web site (if available)
 - Number of all authorizations required for the transport of recovered ODS within Mexican territory.
6. Additional information:

- If ODS are to be destroyed in order to obtain Carbon Credits, proven track record in registering projects under CAR / VCS.

7. Provide a Commitment Letter

B. Commercial Offer

Detailed description of the cost for proposed services:

1. Based upon information in Annex 1, cost for transportation from the points of origin to the destruction facility. The quotation should include the cost of handling and the return of empty containers to the points of origin.
2. Cost for destruction per kg, including temporal storage and handling in the destruction facility.
3. Cost of reporting (reporting requirements are specified in Section V of this Terms of Reference).
4. If a share or the whole of the unwanted ODS are to be destroyed in order to obtain carbon credits, registration cost under one of the two carbon market schemes considered (e.g. validation, monitoring, reporting and verification, etc.)

The proposal must include a detailed time schedule for the destruction of 74.1 metric tons of unwanted ODS. The batches of unwanted ODS (as identified in Annex 1) have to be destroyed in the sequence specified in Annex 2.

Companies are requested to fill the table provided in Annex 2 with an estimation of:

1. Dates when each batch of unwanted ODS will be transported from its collection point (as detailed in Annex 1) to the destruction facility;
2. Dates when each batch of unwanted ODS will be destroyed.

III. LANGUAGE REQUIREMENTS

The personnel provided by the supplier for undertaking the above-defined tasks will be required to have working knowledge of Spanish and English (both written and spoken); the ability to provide native Spanish speakers will be an asset

IV. DELIVERABLES

A. Reporting to the National Ozone Unit of Mexico

Destruction facilities must report on the destruction of each batch of unwanted ODS to the National Ozone Unit of the Government of Mexico. The information provided should include:

1. General Data of the Destruction facility.
2. Name of the Developer.
3. Name of the Generator.
4. Origin of the unwanted ODS.
5. A quantity of unwanted ODS destroyed.
6. Gas composition.
7. Certificate of Destruction - ID number.
8. Serial, tracking, or ID Number of all tanks for which ODS destruction occurred.
9. Destruction dates.

All this information must be registered on line through the Monitoring System provided by National Ozone Unit from SEMARNAT.

B. Reporting to UNIDO

1. The contractor shall submit a Work Plan one month after the signature of the contract. It should include a schedule for the planned destruction activities within the contract. The information should be consistent with the information given under Section III and Annex 2 of the present Terms of Reference.
2. Progress report: the contractor shall submit a progress report after the destruction of at least 37 metric tons of unwanted ODS, no later than 7 months after signature of contract. The report has to contain the data of the destroyed ODS as set out under the reporting criteria to the National Ozone Unit.
3. Draft final report: the contractor shall submit a draft final report after the complete destruction of the 74.1 metric tons of unwanted ODS. The report has to contain the data of the destroyed unwanted ODS as set out under the reporting criteria to the National Ozone Unit.
4. Final report: the contractor shall submit a final report at the end of the contract and should incorporate comment from UNIDO.

V. RECOMMENDED TABLES OF SCOPE OF SERVICES

UNIDO RFP reference No.
Scope of services

Technical table

UNIDO REQUIREMENTS		TO BE COMPLETED BY THE INVITEE	
Item	Name and required parameters	Compliance*)	Remarks**)
		yes/no	
1	General data from the company		
2	Detailed description of the destruction facility and certification		
3	Emission values of the destruction technology		
4	Additional information		
5	Provide a Commitment Letter		

*) compliance must be confirmed in detail in the by the contractor's offer and technical documentation and will be verified by UNIDO during technical evaluation;

**)if not compliant with UNIDO's required parameters, the invitee must indicate his parameters in this column

Commercial table

UNIDO REQUIREMENTS			TO BE COMPLETED BY THE INVITEE	
Item	Name and required parameters	Quantity	unit price	total item price
			currency	currency
1	Transportation costs as per Annex 1			
2	Cost for destruction per kg including storage and handling			
3	Cost of reporting			
4	Cost of registration of destruction activities under a voluntary carbon market scheme, if applicable			
	Total price:			

VI. EVALUATION CRITERIA

The company has to provide

1. General Data from the company
2. Detailed description of the destruction facility and certification
3. Emission values of the destruction technology
4. Commitment letter
5. Transportation costs
6. Cost for destruction per kg including storage and handling
7. Cost of registration of destruction activities under a voluntary carbon market scheme, if applicable

blank
page



Establishment of a Private-Public Financing System for Disposal of ODS for the Philippines

February 2014

Prepared for

The World Bank Group
1818 H Street NW
Washington, DC 20433

Prepared by

ICF International
1725 Eye Street, Suite 1000
Washington, DC 20006

blank
page

Contents

1. Background	1
2. Inventory Development	3
2.1. Development of Inventory Tool.....	3
2.2. Data Collection and Tool Population.....	3
3. Building Capacity to Undertake ODS Destruction Projects	6
3.1. Workbook on the Management of Unwanted ODS	6
3.2. Overview of ODS Destruction Technologies.....	7
4. Financing Options for Destroying Unwanted ODS	7
4.1. Available Markets for ODS Destruction Credits	8
4.2. Cost Considerations.....	12
4.3. Current Voluntary Market Prices.....	14
4.4. Potential Revenue from the Destruction of ODS in the Philippines.....	15
5. Evaluation of Options for the Philippines	16
6. Next Steps for Implementation	18
6.1. Implementation of Phase I: Near-Term Next Steps.....	18
6.2. Implementation of Phase II and Phase III.....	21
7. References.....	22
Appendix A. Workbook on the Management of Unwanted ODS in the Philippines	A-1
Appendix B. Importance of Evaluation Criteria Relative to Financing Options	B-1
Appendix C. Potential Project Developers	C-1
Appendix D. Sample Terms of Reference for Project Developer	D-1

blank
page

Acronyms and Abbreviations

Acronym / Abbreviation	Stands For
CCO	Chemical Control Order
CDM	Clean Development Mechanism
CFC	chlorofluorocarbon
DENR	Department of Environment and Natural Resources
EMB	Environmental Management Bureau
EOI	expression of interest
GHG	greenhouse gas
GWP	global warming potential
HCFC	hydrochlorofluorocarbon
HFC	hydrofluorocarbon
kg	kilogram
km	kilometer
LVC	low volume consuming country
MLF	Multilateral Fund
MRV	measurement, reporting, and verification
MtCO ₂ e	million metric tons carbon dioxide equivalent
NCPP	National CFC Phase-out Management Plan
ODS	ozone depleting substance
OEWG	Open-Ended Working Group
PMR	Partnership for Market Readiness
PMU	Project Management Unit
tCO ₂ e	metric tons carbon dioxide equivalent
TEAP	Technology and Economic Assessment Panel
ToR	terms of reference
UNEP	United Nations Environment Programme
UNIDO	United Nations Industrial Development Organization
VCS	Verified Carbon Standard
VCU	verified carbon unit



1. Background

The Montreal Protocol on Substances that Deplete the Ozone Layer has been immensely effective at reducing the production and consumption of ozone depleting substances (ODS) worldwide. While the production and consumption of ODS has dramatically diminished, a large amount of ODS still remains in equipment, products, and stockpiles held by country governments as well as industrial and commercial users. Because emissions from ODS banks are not explicitly controlled by the Montreal Protocol, there is significant risk that these ODS will be released to the atmosphere, contributing to both ozone depletion and global climate change. Many countries have enacted regulations that prohibit the venting of ODS; however, regulations alone are often not enough.

To prevent inadvertent or intentional emissions of ODS banks, financial incentives must be put in place to encourage proper management and ensure eventual destruction of this unwanted material. The high global warming potential (GWP) of ODS means that their destruction has the ability to generate significant volumes of carbon credits. Indeed, a study prepared for the World Bank in 2010 found that opportunity exists for financing the destruction of ODS through the voluntary carbon market (ICF 2010).

To help countries operating under Article 5(1) of the Montreal Protocol take advantage of this opportunity, ICF International was commissioned by the World Bank to explore options for engaging the private and public sectors in financing the destruction of unwanted ODS in the Philippines.¹ The remainder of this report provides a summary of the results of this effort, including the following:

- ❖ Development of an inventory of unwanted ODS (Section 2);
- ❖ Building capacity (Section 3);
- ❖ Exploring options for destroying unwanted ODS (Section 4);
- ❖ Evaluation of options for the Philippines (Section 5); and
- ❖ Next steps for implementation (Section 6).

Financing the Destruction of ODS through the Voluntary Carbon Market

The 2010 study prepared for the World Bank assessed opportunities for financing the destruction of unwanted ODS through the voluntary carbon market. The study concluded that there is a market for ODS destruction



through frameworks such as the Verified Carbon Standard and Climate Action Reserve. The study recognized that some challenges do exist, but that overall the voluntary market is likely a win-win opportunity.

For more information, see the full report online: <http://documents.worldbank.org/curated/en/2010/02/14551009/study-financing-destruction-unwanted-ozone-depleting-substances-through-voluntary-carbon-market>.

¹ As part of this work, ICF also explored options for engaging the private and public sectors in financing the destruction of unwanted ODS in Indonesia. The outcome of this activity is documented in a separate report.

Long Term Approach for Recovery, Collection, and Management of ODS

There are three main sources of ODS: (1) ODS stockpiles that are obtained by Customs when illegally imported into the country; (2) ODS recovered from large equipment (e.g., chillers) during decommissioning; and (3) ODS recovered from small equipment (e.g., household refrigerators, window air conditioning units) at end-of-life. A phased approach should be undertaken to ensure systems are established to properly manage each source of ODS. While this report focuses on assessing options for implementation of Phase I, all three phases, as described below, should be considered for long term planning.

Phase 1: ODS Stockpiles from Illegal Imports – Destroying illegally imported stockpiles of ODS represents the first phase of ODS management. ODS stockpiles are owned by the government and are often stored at a central location, making them the easiest source of ODS to manage. However, stockpiles of ODS that are left unattended will slowly vent to the atmosphere. Therefore, prompt disposal is necessary to avoid emissions.

Phase 2: ODS Recovered from Large Equipment – The second phase of ODS management involves collection and destruction of ODS recovered from large equipment. When large pieces of equipment such as chillers are decommissioned, the refrigerant is often recovered since there is an economic incentive to reuse it for the servicing of other equipment. Additionally, many countries have regulations in place that require the recovery of ODS from large equipment. Retired chillers that use large amounts of refrigerant provide a steady stream of ODS that, if not reused, will be stockpiled and eventually vented into the atmosphere. The development of systems to collect and destroy ODS from retired large equipment is needed to ensure proper management of ODS from this source. Establishing these systems now is also important for the future management of HFCs.

Phase 3: ODS Recovered from Small Equipment – The third phase of ODS management involves ODS recovered from appliances such as refrigerators, freezers, air conditioners, and dehumidifiers, which historically used CFCs and now largely rely on HCFCs and HFCs. Individually, these pieces of equipment contain only a small amount of refrigerant (e.g., 0.13 – 2 kg). Thus, there is little economic incentive to recover this material. However, with more than 20 million households in the Philippines (National Statistics Office 2012), collectively, the refrigerant that can be recovered from small equipment represents a significant opportunity for generating carbon credits from destruction. To prohibit venting and ensure refrigerant is recovered at end-of-life, regulations should be established along with collection and recycling programs. The United States, Brazil, Mexico, and many countries in Europe have already established appliance recycling programs to encourage the proper management of ODS. Establishing these collection centers now is also important for the future management of HFCs.

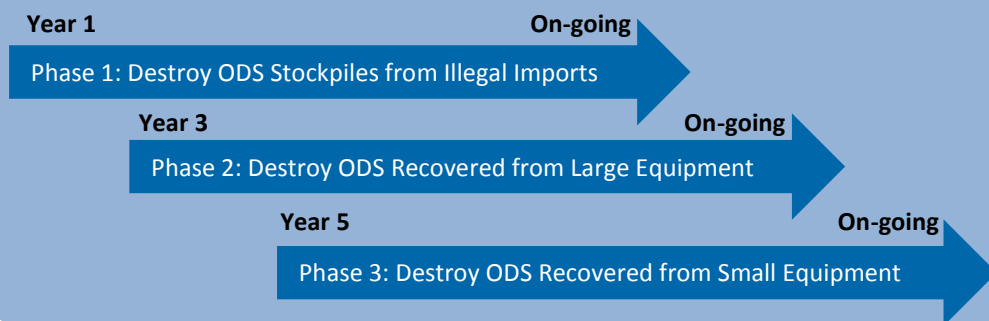

2. Inventory Development

As a first step to managing banks of unwanted ODS, an inventory detailing the quantity, type, purity, location, and ownership of the material must be developed. This step was completed in two parts: through (a) the development of an inventory tool and (b) data collection and tool population, as described in the sections that follow.

2.1. Development of Inventory Tool

To assist country governments in the development of an ODS inventory, an Excel-based inventory tool was developed. The inventory tool is designed to collect information on ODS contained in stockpiles, chillers, and other equipment (e.g., refrigerators and air conditioners). The inventory tool also includes a summary table that auto-completes to show total quantities of unwanted ODS held domestically. A detailed description of the inventory tool along with guidance on how to populate the tool is presented in the Workbook provided in Appendix A.

ODS Stockpiles

Stockpiles of ODS are generally stored in cylinders within large facilities and warehouses. These cylinders are often pressurized and can be distinguished using color, pressure, size, weight, or shape. The refrigerant industry typically universally distinguishes the type of refrigerant in a cylinder primarily based on color and pressure. These stockpiles of ODS are often consolidated into larger cylinders or storage tanks prior to destruction to avoid additional shipping expenses.

2.2. Data Collection and Tool Population

To populate the inventory tool, data on unwanted ODS residing in the Philippines were compiled using multiple approaches. First, existing inventory information was requested from the Philippines Department of Environment and Natural Resources (DENR). Sources reviewed include inspection reports and verification reports from Bureau of Customs as well as equipment inventory summaries compiled in support of other projects and programs under the auspices of DENR. To supplement and verify the stockpile data, site visits to storage facilities were then conducted. During the site visits, stockpiles were visually inspected and findings were documented.² As a last step, information was compared, synthesized, and transcribed into the Excel-based inventory tool. The remainder of this section further documents the data collection experience in the Philippines, including a summary of the country's inventory results and data challenges and limitations.

² No sampling of containers or other physical examination of stockpiles was conducted for this assignment. Instead, ICF relied on previously conducted and quality controlled inventories. It is expected that if a project is developed, detailed verification will be undertaken at that time (i.e., as part of the third party MRV process).

Data Collection in the Philippines

Working with the Philippines DENR, the following sources of information were used to populate the inventory tool for the Philippines:

- **Inspection Report:** *A Report on the Conduct of Inspection of Seized Refrigerants under the Custody of the Bureau of Customs* was provided to ICF by DENR. The report summarizes shipments that were seized by the Bureau of Customs and inspected at the Manila International Container Port in North Harbor, Manila on June 19, 2012.
- **Email Correspondence:** To supplement the information in the inspection report, DENR provided estimates of stockpiles held by the Bureau of Customs at the Ecology Center of EMB in Quezon City through email correspondence. A site visit of the Ecology Center was intended but not conducted because the refrigerant cylinders stored at this facility are located inside stacked inter-modal transport containers that are bolted shut.
- **Verification Report:** Verification of the recovered refrigerants being held at the Delsa facility in Muntinlupa was conducted by the NCPP Project Management Unit (PMU) in June 2013. A report detailing the cylinder serial number, refrigerant type, tare weight, gross weight, and net weight of each cylinder at the facility, as compiled by the PMU, was provided to ICF by DENR.
- **Delsa Site Visit:** To supplement the verification report of the material being held at the Delsa facility, ICF's in-country consultant visited the Delsa facility to visually inspect the cylinders. Through discussions with the facility manager, it was determined that a large number of the cylinders stored at the facility contain ODS but are incorrectly or not clearly labeled. In addition, due to inadvertent leakage over time, the quantity of the contents within each cylinder may be lower than specified.
- **Installed Chiller Summary:** An inventory of installed chillers was compiled in 2011 by Berkman, a contracting company for DENR, to support the Philippines Chiller Energy Efficiency Project. The inventory list, which is known to not be exhaustive and does not specify refrigerant type, was cross-walked with chiller inventory data from 2006 (also compiled to support the Philippines Chiller Energy Efficiency Project) to identify the refrigerant contained in installed chillers, to the extent possible. In neither list was refrigerant charge size provided; however, cooling capacity was provided, which was used as a proxy to estimate refrigerant charge.

Philippines Inventory Data Challenges and Limitations

Several assumptions were made to address gaps and inconsistencies in the data compiled from the various sources. Challenges and limitations of note include the following:

- It was not possible to identify the types of ODS found in "mixtures" or unlabeled cylinders stored at the Delsa facility.
- The actual amount of material contained within cylinders stored at the Delsa and Customs' facilities may be lower than indicated by the labels due to inadvertent leakage of the contents

over time. Experience from an ODS destruction project in Nepal, spearheaded by UNEP under the MLF, indicates that leakage from cylinders in storage was about 10-12% over a ten plus year time frame. This suggests that the Philippines inventory may be about 10% overstated.

- Stockpiles held by the Bureau of Customs were not visually inspected by the ICF team, and an inventory of these stockpiles was not available. Instead, information provided by email from DENR was used to estimate the number, location, and content of storage vessels.
- Some of the chillers identified in the 2006 and 2011 inventories may no longer be in service. In addition, complete data on refrigerant type and charge size was not available in the inventories provided. Instead, assumptions were made regarding the refrigerant type, and the cooling capacity was used to estimate refrigerant charge size (i.e., 0.9 kilograms are required for each tonne of cooling capacity).

Philippines Inventory Results

Using the sources described above, a preliminary inventory of ODS was developed for the Philippines, as presented in Table 1. Given the data challenges and limitations, further inspection and verification of the material is necessary to validate these preliminary findings. In addition, other efforts will need to be undertaken to expand and verify the chiller inventory and develop an inventory of ODS contained in other equipment (e.g., refrigerators/freezers).

Table 1: Summary of Preliminary Inventory of ODS in the Philippines

Chemical	Stockpile Inventory		Chiller Inventory ^a	
	kg	tCO ₂ e	kg	tCO ₂ e
CFC-11	50	239	24,113	114,535
CFC-12	30,255	329,781	3,047	33,212
R-502	48	224	-	-
CFC Subtotal	30,353	330,244	27,160	147,747
HCFC-22	7,982	14,448	106,309	192,420
HCFC-123	11	1	130,479	10,047
HCFC-141b	90	66	-	-
HCFC Subtotal	8,083	14,515	236,788	202,467
HFC-134a	463	662	110,276	157,695
R-404A	161	632	-	-
R-403B	17	74	-	-
R-407C	6	10	-	-
R-410A	23	47	-	-
R-413A	9	20	-	-
HFC Subtotal	679	1,445	110,276	157,695
Mixture ^b	15,597	69,679	-	-
Unknown	681	NA	-	-
TOTAL	39,115	346,204	374,224	507,909

^a The chiller inventory is estimated based on the cooling capacity of equipment currently in use.

^b Based on the sources consulted, it is estimated that the mixtures held at the Delsa facility contain largely HCFC-22 as well as some CFC-11 and CFC-12. Additionally, the mixtures held by Customs are estimated to contain either a mixture of HFC-134a/CFC-12 or HFC-134a/CFC-12/HCFC-22/HC. This information was used to estimate the tCO₂e-weighted inventory.

3. Building Capacity to Undertake ODS Destruction Projects

3.1. Workbook on the Management of Unwanted ODS

To assist countries operating under Article 5(1) of the Montreal Protocol to take advantage of the opportunity to finance the destruction of ODS through the carbon market, a *Workbook on the Management of Unwanted ODS* was developed. The workbook, which was developed by ICF under contract with the World Bank, is intended to serve as a general guide on how to manage unwanted ODS held by country governments. The workbook includes information on the following:

- International agreements that govern the movement of ODS;
- Guidance on how to develop an inventory of unwanted ODS;
- Guidelines for proper handling of unwanted ODS; and
- An overview of the project assessment and development process, including strategies for engaging the public and/or private sector in an ODS destruction project.

The *Workbook on the Management of Unwanted ODS* was disseminated to the Philippines DENR during the 33rd Open-Ended Working Group (OEWG) of the Parties to the Montreal Protocol held in Bangkok in June 2013 for review by the government. Additional conversations and meetings involving the World Bank, ICF, and DENR have since taken place to ensure a common understanding of the workbook's content and the tasks at hand. Local consultants have also been engaged to allow for continued support for the country governments (i.e., support beyond ICF's contract with the World Bank).

To inform this report, an overview of relevant domestic regulations in the Philippines is provided in the version of the workbook presented in Appendix A. DENR is expected to review and further populate the workbook with detailed country-specific information. In addition, DENR is expected to take the time to understand the systems that must be put in place to properly handle unwanted ODS, and to identify possible improvements to their national systems and regulations. Ensuring that these systems are in place now is critical for preventing the venting of these chemicals and ensuring eligibility under various carbon markets not only today, but also in the future as more ODS (and possibly other harmful chemicals) are phased out of the global market. Further discussion on implementation of a long-term approach to the management of ODS and other F-gases is found in section 6.2 of this report.

Overview of Filipino ODS Regulations

- **Republic Act #6969**, known as the "Toxic Substances and Hazardous and Nuclear Wastes Control Act of 1990" regulates, restricts, or prohibits the importation, manufacture, processing, sale, distribution, use, and disposal of chemical substances and mixtures that present unreasonable risk and/or injury to health or the environment, including ODS.
- Under the **Chemical Control Order (CCO)** for Ozone Depleting Substances, DENR established import controls and a phase-out schedule for all substances listed under Annex A, Annex B, and Annex C of the Montreal Protocol.

3.2. Overview of ODS Destruction Technologies

In addition to properly managing ODS, feasible options for the disposal of ODS should also be explored. Currently, there is no local capacity for ODS destruction in the Philippines. As such, the Philippines government may want to explore technical options for building local capacity to further increase future opportunities for ODS destruction. In 2002, TEAP identified a variety of technologies that can be used to destroy ODS, as outlined below:

- **Incineration technologies** use a controlled flame to destroy ODS in an engineered device. Common technical options, such as rotary kilns and cement kilns, use hydrocarbon fuels, while reactor cracking is fuelled by hydrogen. Incineration technologies are commonly used worldwide and offer high destruction capacity at a relatively low operating cost.
- **Plasma technologies** use intense heat from plasma to destroy ODS. Specific technical options are differentiated according to the method of plasma generation. Some have the advantage of being compact and portable, yet require a significant amount of energy to operate as well as trained technicians to service and maintain the equipment.
- **Other non-incineration technologies** destroy ODS without using incineration or plasma-based techniques. Some of these techniques, such as solvated electron decomposition, operate at relatively low temperatures and use chemical processes to destroy the material. Those that operate at high temperatures, including superheated steam reactors, use hydrogen or hydration to break apart the ODS molecules.

See the report of the TEAP (2002)³ and ICF (2009)⁴ for detailed information on technology options.

4. Financing Options for Destroying Unwanted ODS

The ability to finance the destruction of ODS through the voluntary carbon market is based on two key factors: (1) the availability of a basic market structure to support ODS destruction, and (2) sufficient demand in the market for carbon credits from ODS destruction projects (ICF 2010). While the market structure is known to exist—through both the voluntary and compliance carbon markets—the demand for carbon credits from ODS destruction projects remains uncertain. In addition, due to the criteria established for market-specific offset programs, not all markets currently allow for the inclusion of carbon credits generated from the destruction of ODS sourced internationally. The remainder of this section explores the feasibility of generating ODS destruction carbon credits from existing and anticipated carbon markets, and the implications for financing ODS destruction in the Philippines.

³ Available at: http://ozone.unep.org/Assessment_Panels/TEAP/Reports/Other_Task_Force/TEAP02V3b.pdf.

⁴ Available at: http://ozone.unep.org/Data_Reporting/USA-Decision-XX-7-ODS-Destruction.pdf.

ODS Destruction Projects: 2012 Market Share

In 2012, there was a notable market for ODS destruction projects, as shown in Figure 1. While ODS destruction credits represented roughly 7% of all offset credits generated globally in 2012, the majority of these projects were aimed at U.S. preparations for the California cap-and-trade compliance market, which require the ODS to be sourced from within the United States.

Figure 1: Market Share by Project Type, 2012

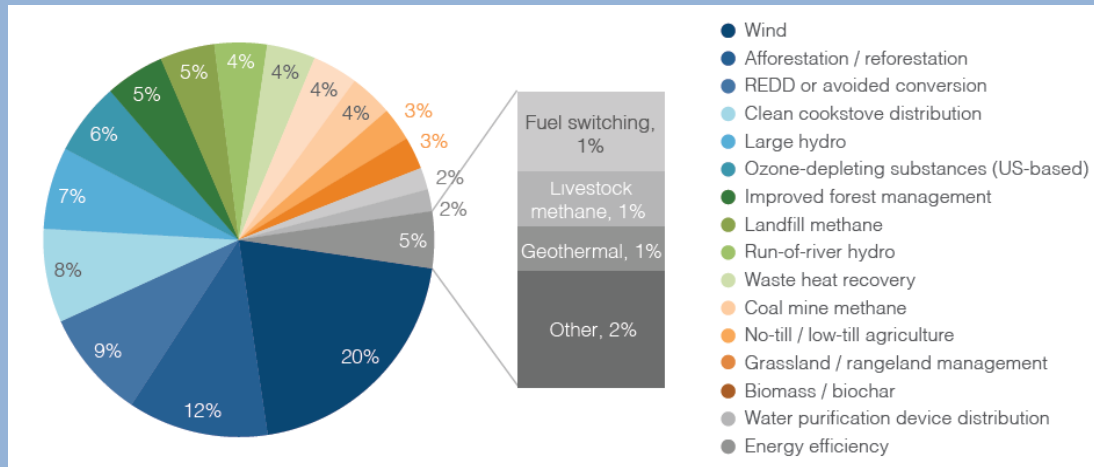

Source: Ecosystem Marketplace (2013)

4.1. Available Markets for ODS Destruction Credits

Although a number of voluntary and compliance carbon markets exist, only some allow for the generation of carbon credits from the destruction of ODS and even fewer allow for the generation of carbon credits from the destruction of ODS sourced from the Philippines. Currently, ODS destruction projects are not eligible for offset credits under the Kyoto Protocol or its flexibility mechanisms (i.e., the Clean Development Mechanism). ODS destruction projects with material sourced outside the United States or Canada are also not eligible for offset credits under California’s or Quebec’s compliance programs.

The existing international platforms that are available to finance the destruction of ODS from Article 5 countries include the Climate Action Reserve (the Reserve) and the Verified Carbon Standard (VCS). In addition, national carbon markets have been or are currently being established in a number of Article 5 countries throughout the world as a result of the Partnership for Market Readiness (PMR) program, and ODS offsets may be eligible in these national markets. The opportunity to use these existing and anticipated frameworks to finance the destruction of ODS is discussed below.

ODS Destruction under the Compliance Market in California and Quebec

California and Quebec have both established cap-and-trade programs, setting an enforceable compliance obligation beginning with the 2013 GHG emissions. Under both programs, ODS destruction offset credit protocols have been adopted. However, in order to be eligible for credits under these programs, all ODS must originate domestically.

The destruction of ODS sourced from domestic material is currently the preferred project type for buyers under California’s compliance market. As shown below in Figure 2, in 2012, more than 4 million metric tons of carbon dioxide equivalent (MtCO₂e) were generated by US-based ODS destruction projects, representing roughly 7% of all offset credits generated globally. These credits were transacted at an average \$9.2/credit on average, up from \$8/credit in 2011 (Ecosystems Marketplace 2013).

Figure 2: Transacted Volume and Average Price by California Offset Type, 2011-2012



Source: Ecosystem Marketplace (2013)

While destruction of unwanted ODS from developing countries—including the Philippines—are not eligible for credits under either California’s or Quebec’s compliance program, these programs serve as a valuable example for future compliance markets that may be established in other countries at the national level. Furthermore, these markets should be monitored closely as it is possible that in the future they will support inclusion of ODS destruction projects that generate credits with material sourced from developing countries.

Destruction under the Climate Action Reserve, “The Reserve”

The Reserve is a nonprofit organization that establishes standards for carbon offset projects, oversees independent third-party verification bodies, issues carbon credits generated from such projects, and tracks the transaction of credits over time. In late February 2010, the Reserve adopted two new offset project protocols for ODS destruction. The protocols, which serve as standardized approaches for

quantifying and monitoring reductions in GHG emissions from ODS destruction projects, are for material sourced domestically and for ODS imported into the United States from Article 5 countries.

Per the latter protocol, material that resides in the Philippines can be destroyed for carbon credits under the Reserve; however, some limitations do exist. Specifically, only Annex A, Group I CFCs (i.e., CFC-11, CFC-12, CFC-113, CFC-114, and CFC-115) used in refrigeration applications are eligible for crediting under the protocol. In addition, material must be destroyed within the United States or its territories, and come from one of the following sources:

1. Privately held stockpiles of used ODS refrigerant that can legally be sold to the market;
2. Article 5 government stockpiles of seized ODS refrigerant that can legally be sold to the market;
3. Article 5 government stockpiles of seized ODS that cannot be legally sold to the market; or
4. Used ODS refrigerant recovered from industrial, commercial, or residential equipment at servicing or end-of-life.

In total, there have been 34 ODS destruction projects registered under the Reserve, five of which used the Article 5 protocol. Three of these projects (i.e., CAR596, CAR597, and CAR 691) involved virgin private stockpiles of CFC-12, one project (i.e., CAR826) involved mixed CFC-12 sourced from end-of-life appliances, and the most recent project (i.e., CAR955) involved virgin, government stockpiles of CFC-12 that were seized from an illegal import. A summary of these projects are provided below in Table 2.

Table 2: Article 5 ODS Destruction Projects Registered under the Reserve

Project ID	Project Developer	Source Country	Credits Registered	Date Registered
CAR596	Coolgas, Inc.	India	683,087	5/12/2010
CAR597	Coolgas, Inc.	India	551,802	10/22/2010
CAR691	Reclamation Technologies Inc.	Mexico	2,602,812	6/21/2011
CAR826	OEKO Service Luxembourg S.A.	Mexico	89,834	6/7/2012
CAR955	EOS Climate Inc.	Nepal	82,391	5/24/2013

Source: Climate Action Reserve (2013).

In addition to the projects that have already been registered, the Multilateral Fund (MLF) has recently approved several projects that intend to utilize the A5 destruction protocol under the Reserve. For example, in Mexico with assistance from UNIDO, MLF financing is being used to finance the destruction of CFC-12 collected from refrigerator de-manufacturing processes. The revenue from the credits, if generated and sold, will be used to start a self-sustaining ODS waste management system, with annual revenue from the credits being fed back into the waste management system. Similarly, in Nigeria with assistance from UNIDO, MLF funding will be used to finance ODS destruction projects, with the potential revenue from the credits being used to establish a national Appliance Replacement Programme that incentivizes recycling. A portion of the anticipated profit may also be used to improve local capacity for ODS waste management. As another example, in Turkey with assistance from UNIDO, revenue from the

destruction of ODS is intended to be used to sustain and improve Turkey's ODS recovery and collection system, with the ultimate goal of building local capacity for ODS destruction.

Project Highlights

Nepal: After confiscating an illegal import of CFCs in 2004, the Government of Nepal received MLF funding for a pilot ODS destruction project—the first of its kind in Low Volume Consumption Countries (LVCs). With assistance from UNEP, Nepal considered numerous options for destroying the material (e.g., destruction within Nepal using a mobile unit; export to Japan, Indonesia, Europe, or the United States for destruction). Ultimately, export to the United States for credit generation under the Reserve was identified as the most economically and technologically feasible option. The project was successfully registered with the Reserve in May 2013. While credits from the project have successfully been generated, a buyer for the credits has yet to materialize.

Turkey: With assistance from UNIDO, Turkey is implementing a project that will involve the collection and disposal of ODS from decommissioned chillers. Depending on the purity and quantity of material, carbon credits will be generated from this project under the Reserve. The project also includes a training component to improve the capacity of local staff to execute similar projects in the future.

Destruction under the Verified Carbon Standard (VCS)

Another option for generating offset credits from ODS destruction is through the VCS. The VCS is a voluntary GHG program that issues and tracks carbon credits, also known as verified carbon units (VCUs) under the program. In late January 2010, the VCS expanded its GHG program to cover ODS by approving a series of eligibility criteria for ODS destruction projects. In September 2011 a VCS methodology (VM0016 v1.0) on the *Recovery and Destruction of ODS from Products* was approved.⁵ This methodology can be applied to either ODS refrigerants and/or ODS blowing agents. Annex A, Group I CFCs and Annex B, Group I CFCs are currently eligible under the methodology,⁶ and destruction is allowed to occur in any country that can meet the technical requirements.

Given the criteria of the methodology, destruction of unwanted ODS that currently resides in the Philippines is eligible for credits under the VCS, with the option of destruction taking place either within the Philippines (if capacity were available) or elsewhere. Although the opportunity exists, no ODS destruction projects have been registered to-date under the VCS; however, a project led by Energy Changes is currently under development.

⁵ In addition to new methodologies that are submitted for review and approval under the VCS, the VCS also accepts projects prepared under the Reserve and CDM methodologies.

⁶ Annex C, Group I HCFCs are also eligible under the methodology after the host country or country from which the ODS destroyed by the project is imported implements a production or consumption phase-out. The Montreal Protocol requires a full phase-out of HCFCs in Article 5 countries starting on January 1, 2040; however, the VCS recognizes countries that phase-out ODS in advance of their Montreal Protocol phase-out deadline.

Destruction under National Carbon Markets

One possible alternative approach to the voluntary carbon market is to use initiatives that rely on national carbon markets. Under this approach, baselines for certain industries are established as country governments move towards establishing mandatory reductions for individual entities in select industrial sectors. The Partnership for Market Readiness (PMR)—a grant-based program that provides funding and technical assistance for the collective innovation and piloting of market-based instruments for GHG emissions reduction—is currently being used to help develop such initiatives, providing opportunity for companies to use ODS offset projects to meet reduction targets.

The PMR is currently made up of 13 Contributing Participants and 16 Implementing Country Participants. As of March 2013, all 16 Implementing Country Participants have received preparation funding to formulate a Market Readiness Proposal (MRP) while four countries have also received implementation phase funding.⁷ The current Implementing Country Participants are listed below:

- Brazil
- Chile
- China
- Columbia
- Costa Rica
- India
- Indonesia
- Jordan
- Mexico
- Morocco
- Peru
- South Africa
- Thailand
- Turkey
- Ukraine
- Vietnam

4.2. Cost Considerations

One of the most important considerations in determining which ODS destruction platform is appropriate is a comparison between the cost to implement the destruction project and the potential revenue. Responsibilities for bearing project-related costs and accruing revenues will depend on the arrangements for public-private financing made by government agencies in possession of unwanted ODS. More information on these options, which include contracting out, facilitation, and serving as the project developer, is provided in Appendix A.

The overall costs associated with implementing an ODS destruction project may include the costs of collection and/or recovery, transportation, storage, testing, and destruction, in addition to one-time project-related costs, such as project preparation, validation, verification, and registration and issuance fees. The specific cost components will depend on the source of the ODS being destroyed; for example, stockpiled materials have the lowest associated costs since the material is already recovered and stored, while collecting and recovering ODS from equipment—especially in sparsely populated areas—presents higher costs associated with segregation, collection, and in some cases transport of the equipment itself (e.g., household appliances) for ODS recovery in a centralized location.

As requested by Decision XX/7, the Technology and Economic Assessment Panel (TEAP) developed estimates of the full costs of ODS disposal from collection to destruction. For stockpiled material (where

⁷ Although not currently a participant, there is opportunity for the Philippines to become a PMR participant in the future.

collection costs are not applicable), the total cost from processing to destruction is estimated at US\$5.10–7.60 per kilogram. This is slightly less than an estimate from one ODS destruction project developer of US\$9 per kilogram, which includes US\$1/kg for transportation (and associated insurance) and US\$8/kg for destruction. The higher estimate for transportation costs likely include costs incurred during the export of the ODS, which is not accounted for in the TEAP estimates.

Table 3: Unit Cost for Destruction of ODS from Stockpiles and Chillers

Recovery and Destruction Steps	US\$ per kg		Sources
	Stockpiles	Chillers	
Segregation/Collection ⁺	--	\$0–\$2	TEAP 2009
Recovery Processing Costs	\$4–\$25	\$4–\$25	TEAP 2009
Transport Costs (Destruction)*	\$0.02–\$0.10	\$0.02–\$0.10	Adjusted, based on TEAP 2009
Destruction Costs	\$2.20	\$2.20	MLF 2008
Total	\$6.22–\$27.30	\$6.22–\$29.30	

⁺Segregation and collection costs are not included

* Transport costs for recovery are factored into the transport costs for destruction. This assessment estimates that ODS travels approximately 50 miles (80.5 km) to a destruction facility.

In addition to the costs associated with collecting, recovering, transporting, and destroying the ODS, there are costs associated with preparing, verifying, and registering the project with a carbon credit platform. These costs may vary significantly depending on the platform chosen (e.g., the Reserve, VCS, or a national carbon market), as well as the project preparation arrangements. For example, if the country government serves directly as the project developer, it may incur costs to hire consultants to prepare project documentation; alternatively, if the project is contracted out to a developer, that developer may have in-house capabilities and thus lower costs for preparation. Table 4 presents the estimated range of project costs for ODS destruction.

Table 4: One Time Project Costs for Destruction of ODS

Activity	Cost (US\$)	Sources
Project Preparation*	Up to \$60,000, but could be substantially less for a national market or if developed in-house	ICF estimate, see MLF 2009
Verification	Estimates vary from a fixed cost of \$20,000, to \$0.10–\$0.30 per credit	ICF estimate, see MLF 2009; ODS project developer
Registry Annual and Project Fees	Reserve fees are \$500 each for annual and project fees; VCS fees are subject to the registry operator; national carbon market fees are currently undetermined	The Reserve 2013b; VCS 2013
Issuance Fee (per tCO ₂ e)	\$0.10–\$0.20	The Reserve 2013c; VCS 2013

*Includes consultant cost to prepare project documentation and support verification/registration.

The market price per ton of ODS destroyed (or ton of carbon equivalent) plays a significant role in the choice of platform, as the market price determines whether the destruction of ODS is a financially viable solution. Assuming the per-kg and one-time cost estimates for an ODS destruction project outlined in Table 3 and Table 4, respectively, the break-even carbon market price needed for destruction of 1, 10, 100, and 1,000 tonnes of CFC-12 was determined, as shown in Table 5. Carbon credits generated were calculated using the Reserve methodology with default estimates for emissions associated with substitute, transportation and destruction emissions (Reserve 2012). In this table, the break-even cost represents the price that would have to be generated in the carbon market in order to cover full project transaction and recovery, transport, and destruction costs. For the destruction project to turn a profit, the carbon market price would have to exceed the break-even price.

Table 5: Estimated Break-even Carbon Market Price for ODS Stockpiles

Project Size (Including Recovery)	Total Project Cost (thousands of US\$)*	Carbon Credits Generated (tCO ₂ e)	Break-even Carbon Market Price (US\$/tCO ₂ e)
1 tonne CFC-12 destroyed	\$84	10,239	\$8.23
10 tonnes CFC-12 destroyed	\$249	102,385	\$2.43
100 tonnes CFC-12 destroyed	\$1,896	1,023,850	\$1.85
1,000 tonnes CFC-12 destroyed	\$18,400	10,238,500	\$1.79

*Includes average costs of recovery, transport and destruction, plus average of one-time project development costs. These costs are based on those developed by TEAP, but could be higher or lower depending on the local costs of recovery, transport, and destruction.

4.3. Current Voluntary Market Prices

Prices in the voluntary market have traditionally varied considerably depending on the type and location of the project activity, the standard to which it is developed, the perceived quality of the methodology used, and the volume transacted. This remains the case today, with credits from projects with a good “story” behind them, such as solar and other types of renewable energy, still able to command a premium. Industrial gases projects have typically earned prices on the lower end of the spectrum, when compared to solar, wind, and forestry projects. With this in mind, the current average price per carbon credit under the VCS and the Reserve are shown below in Table 6.

Table 6: Average Carbon Credit Prices under Relevant Frameworks

Voluntary Market	Cost in 2012 (US\$/tCO ₂ e)	Cost All Years (US\$/tCO ₂ e)
VCS	\$5.20	\$5.00
Reserve	\$7.10	\$6.90

Source: Ecosystem Marketplace (2013)

Based on stakeholder input, it is estimated that the price of an A5 ODS destruction carbon credit sold on the market today could vary from US\$0.50 to US\$3.50 per tCO₂e. As already noted, the actual price of an A5 ODS destruction carbon credit will vary depending on a variety of factors, and can be influenced by generating demand and interest in these types of projects.

4.4. Potential Revenue from the Destruction of ODS in the Philippines

Based on the state of the carbon market and the preliminary inventory of ODS stockpiles in the Philippines, as presented in Section 2.2, potential revenue from the destruction of ODS can be estimated. Figure 3 below presents the estimated stockpiled inventory of unwanted ODS, broken out by source and chemical type. As shown, an estimated 55 percent of stockpiles in the Philippines are CFCs. On a tCO₂e basis, 79 percent of stockpiles in the Philippines are CFCs.

Figure 3: Philippines ODS and Non-ODS Inventory: Stockpiles⁸

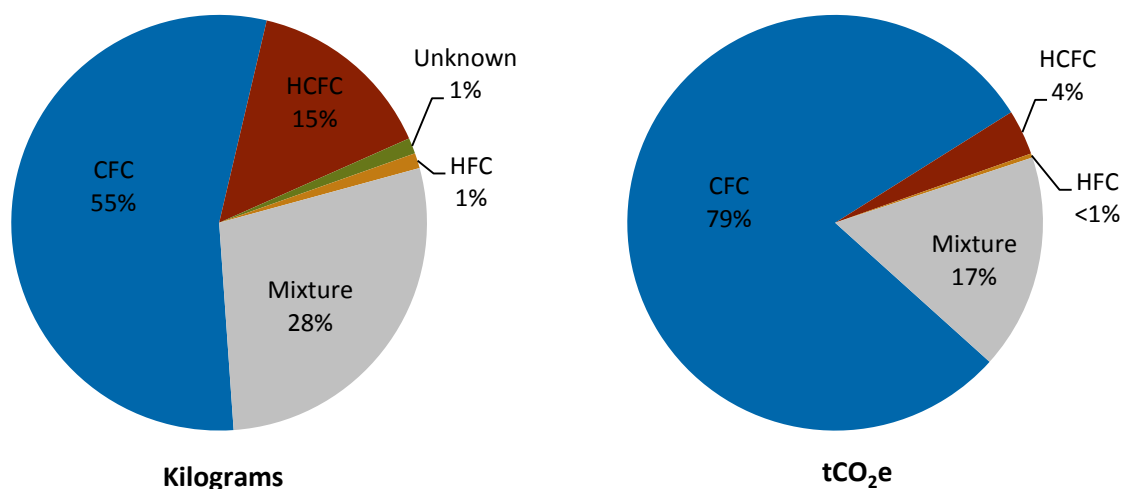

CFCs are currently the only ODS eligible for destruction under VCS and the Reserve. Table 7 below presents the estimated costs and potential carbon credits that could be generated from the destruction of ODS stockpiles in the Philippines. CFCs in chillers and appliances were not considered in this cost analysis since the material is still contained in equipment that is in use in the Philippines and is not readily available for destruction at this time.

Table 7: Costs Associated with Philippine CFC Inventory Destruction

Inventory Type	Stockpile Inventory (kg)	Transportation and Destruction Costs (US\$)*		Issuance Fee (US\$)*		Credits Generated (tCO ₂ e)
		Low Cost	High Cost	Low Cost	High Cost	
CFC-11 Stockpile	50	\$311	\$1,365	\$22	\$45	223
CFC-12 Stockpile	30,255	\$188,208	\$825,997	\$30,977	\$61,953	309,766
Transaction Costs	NA	\$51,000	\$81,000	NA	NA	NA
Total		\$239,519	\$908,362	\$30,999	\$61,998	309,989

*High and low transaction costs and issuance fees estimated based on the ranges in Table 4.

⁸ Mixtures are assumed to be made up of CFC-11, CFC-12, HCFC-22, HFC-134a, and HCs.

Based on the costs presented in Table 7 above, the break-even costs for the Philippine CFC destruction project were determined, as illustrated in Figure 4. As shown, the break-even cost for the “low cost” destruction scenario is US\$0.87/tCO₂e and the break-even cost for the “high cost” destruction scenario is US\$3.13/tCO₂e. Depending on the realized carbon market prices for an Article 5 ODS destruction project under the VCS and the Reserve—which, based on stakeholder input, could potentially be as low as US\$0.50/tCO₂e or as high as US\$3.50/tCO₂e—the destruction of the Philippines’ CFC-11 and CFC-12 stockpiles could result in a positive return.

Figure 4: Break-even price for Philippine CFC Destruction Project

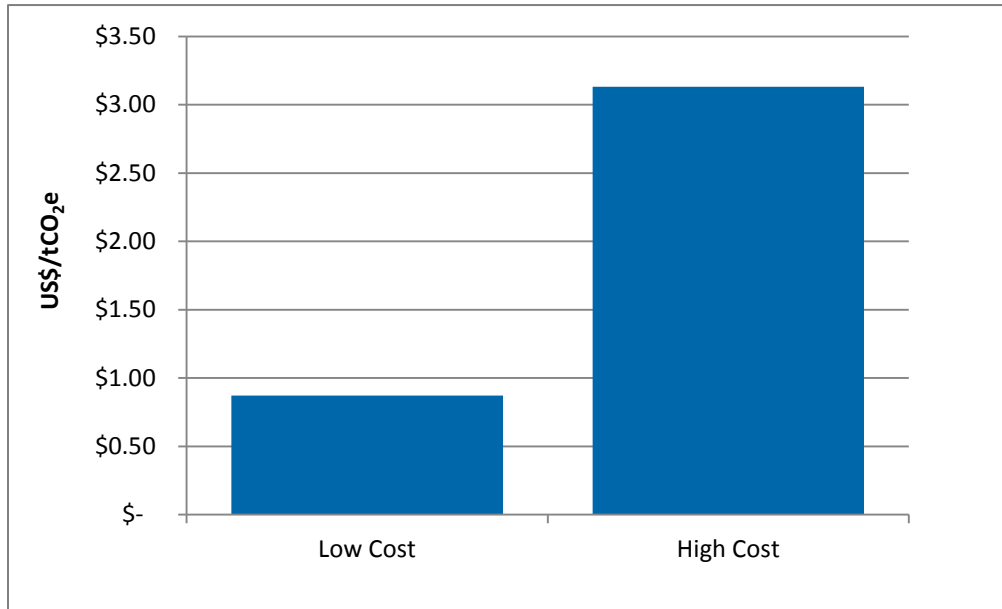

5. Evaluation of Options for the Philippines

As discussed in the preceding sections of this report, the platforms that are currently available to finance the destruction of ODS from Article 5 countries include the Reserve, VCS, and national carbon markets. Evaluation criteria were used to assess the viability of using each option to finance the immediate destruction of stockpiled ODS sourced from the Philippines. The table in Appendix B summarizes the evaluation criteria used for this assessment as well as the importance of meeting each criterion relative to the financing options.

As highlighted in the text box on page 2, the assessment presented below focuses on Phase I of a long term approach for the recovery, collection, and management of ODS in the Philippines. The logic flow for determining the viability of each option for financing destruction of ODS sourced from the Philippines is described. The approach identified here is also relevant when considering options for destruction of material in the future (i.e., when implementing Phase II and Phase III).

National Carbon Market:

- The Philippines is not a participant in the PMR program.
- The Philippines government is not actively in the process of establishing a national carbon market under which ODS destruction credits could be used.

→ *A national carbon market is not a viable financing option for destroying ODS in the Philippines.*

Verified Carbon Standard:

- The average credit price under the VCS is currently high enough to cover projected project costs; this average price is lower than the average credit price under the Reserve.
- Some project developers have voiced interest in developing a project under the VCS, but no A5 ODS destruction projects have been registered under the VCS to-date.
- No national capacity for ODS destruction currently exists in the Philippines.
- Regional capacity does exist (i.e., at a Holcim Plant in Indonesia), but it is unclear whether the destruction and removal efficiency of this facility meets the VCS standard.
- There are no national regulations that limit the export of ODS to other countries with destruction capacity.

→ *It is feasible to finance the destruction of ODS from the Philippines under the VCS.*

The Reserve:

- The average credit price under the Reserve is currently high enough to cover projected project costs, with the average price being higher than the average credit price under the VCS.
- There are no national regulations that limit the export of ODS to the United States.
- A5 ODS destruction projects have been successfully registered under the Reserve
- Project developers have shown interest in developing additional projects under the Reserve.

→ *It is feasible to finance the destruction of ODS from the Philippines under the Reserve.*

Based on the assessment presented above, the viability of each financing option is summarized below in Table 8. As shown, it is technically feasible to finance the destruction of ODS under both the VCS and the Reserve. Actual financing viability, however, is reliant on real-time market demands and the realized market price of the generated carbon credits. Additionally, other factors, such as project developer experience and capacity for destruction may influence which option is ultimately pursued.

Table 8: Viability of Financing Options for the Philippines

Financing Option	Viability
National carbon market	Not Feasible
VCS	Feasible
The Reserve	Feasible

6. Next Steps for Implementation

ODS management is a multi-phased, long-term process. As the focus of this report, the following section presents near-term next steps for the Philippines to successfully destroy their existing stockpiles of ODS. While the current and future market demand for Article 5 ODS destruction credits remains uncertain, the following steps should still be followed to ensure the destruction of the unwanted ODS is carried out in compliance with the technologies, performance parameters, and emissions requirements identified by the Technology and Economic Assessment Panel (TEAP) of the Montreal Protocol.

Following the discussion on near-term next steps, other next steps to plan for the implementation of Phase II and Phase III of this long-term approach to ODS management are presented. These next steps involve establishing a system for the long-term recovery, collection, and management of ODS that is confiscated in the future, originates from servicing operations, or recovered from large and small refrigeration and air conditioning equipment when that equipment is retired.

6.1. Implementation of Phase I: Near-Term Next Steps

A number of steps must be undertaken by the Philippines government to ensure that their existing stockpiles of ODS are successfully destroyed in the immediate future. While it is not required that the Philippines contract out project development responsibilities (as outlined in Section 5.2 of Appendix A), there are many benefits to hiring an experienced project developer to execute the project. With this in mind, recommended next steps for implementation include (1) identification of project financing, (2) identification and onboarding of a project developer, and (3) project execution. As an optional last step, (4) third party validation and project registration may also be undertaken.

Step 1: Identification of Project Financing

Upfront financing will be required to execute the destruction project regardless of the potential for revenue via the voluntary carbon market. As summarized below, several financing options are available to support project development and execution.

- **Multilateral or Donor Financing:** Carbon funds and donor programmes that are supported by multilateral institutions and/or country governments provide one possible source of up-front financing for offset projects. Specific funds or donors that may be willing to provide up-front financing include the Multilateral Fund (MLF), Global Environment Fund (GEF) and European Commission (EC).
- **Private Sector Financing:** Private sector developers or private carbon funds provide another possible source of financing for offset projects. If this financing source is used, financing would likely be provided on commercial terms. It is additionally possible that a private firm would be interested in providing equity financing, whereby they provide upfront costs for an equity stake in the project. In this scenario, there would be no requirement to pay back funds if the project does not generate credits and/or revenue.

- **Debt Financing:** As a final financing option, a bank can provide debt financing in the form of a loan. In this case, the loan would need to be repaid within a fixed amount of time.

Due to the current lack of demand for A5 ODS destruction credits, certain financing sources are more likely to materialize than others. Specifically, it is highly unlikely that either a bank or the private sector will be willing to finance an A5 ODS destruction project at this time. Rather, financing sources that do not require revenue from credit generation for repayment are seen as the best path forward.

Upfront Buyers and Forward Crediting

Although it is currently assumed that no market demand for carbon credits generated from A5 ODS destruction projects exists, if a buyer of the credits was identified upfront and agreed to purchase the credits ex-ante—known as forward crediting—the buyer could serve as the project financier. Under this scenario, the buyer agrees to purchase a certain number of credits that have yet to be generated. In exchange for the upfront payment, the seller provides a certificate confirming the purchase. If the project under-delivers, the seller is not obligated to compensate the purchaser for the delivery shortfall, unless required to by contract.

Unfortunately, it is anticipated that identification of a buyer for A5 ODS destruction credits (upfront or after credit registration) will be a difficult task since destruction projects are generally not viewed as attractive projects. Brokers are available to assist in prearranging a buyer, and may also keep registries of potentially interested buyers. Furthermore, brokers may undertake targeted outreach to secure an interested buyer. Organizations such as the World Bank, other multi-lateral institutions, and private sector entities looking to offset their emissions to become carbon neutral could also be interested in purchasing offsets from A5 ODS destruction projects, and their actions may help stimulate market demand by casting these projects in the positive light they deserve.

Step 2: Identification of Project Developer

Regardless of the financing structure selected, the Philippines will need to identify and onboard a project developer. There are a number of project developers who have experience developing A5 ODS destruction projects who have voiced interest in developing new projects, if approached. In addition, other experienced project developers who do not have direct experience with A5 ODS destruction projects have also expressed some interest in developing A5 ODS destruction projects. A list of potential project developers is provided in Appendix C.

The procurement process to contract a project developer from the private sector must be undertaken in accordance with national rules and regulations, but generally involves the (a) preparation and release of a request for an Expression of Interest (EOI) to potential project developers; (b) selection of a short-list of qualified candidates from those submitting EOIs; (c) preparation and release a Terms of Reference (ToR) to the short-listed candidates; and (d) selection and contract establishment with the chosen company. This process is outlined further below.

- **Preparation and release of a request for an EOI** - The request for EOIs should include brief background on ODS destruction, a short description of the ODS stockpiles held by the Government of the Philippines and the expected role of the project developer, and a request for interested companies to submit information related to their company qualifications, experience managing ODS destruction projects, and proposed personnel.
- **Selection of a short-list of qualified candidates** - After the EOIs have been received, the Government should select a short-list of candidates by applying pre-determined evaluation criteria and/or a ranking process that aligns with national procurement rules. These criteria might include relevant experience managing ODS destruction projects, experience working in the Philippines, and key staff qualifications.
- **Preparation and release of ToR** – The ToR should elaborate on the EOI, providing additional detail on the ODS stockpiles held, and requesting interested companies to submit a work plan explaining how they intend to approach the project, a project schedule, a proposal for ownership of the resulting carbon credits, and a financial proposal. The criteria for evaluating and selecting a successful proposal should also be provided; these may be similar to those utilized in the EOI stage, with an additional criterion related to the financials. A question-and-answer period might be useful to ensure that project developers have the information they need to prepare realistic proposals. An example ToR is provided in Appendix D.
- **Selection of company** - After the proposals have been received, the Government should select the successful candidate based on the pre-determined evaluation criteria.

Step 3: Project Execution

Once the project developer has been selected and on-boarded, they will be responsible for executing the project, with oversight from the Philippines government. As a first step in the development process, the project developer will need to facilitate the testing of the stockpiled material. While the preliminary inventory compiled for this report serves as an indicator of what is likely to be available in the Philippines for immediate destruction, testing of the material, which should be undertaken in accordance with the management procedures described in Appendix A, is still needed to verify the quantity of stockpiled ODS and potential for credit generation. In addition to inventory verification, the project developer will also be responsible for arranging transportation and destruction of the material. Such activities may require cooperation from Customs or other in-country organizations.

Step 4: Project Validation and Registration (Optional)

As an additional option, third party validation and project registration may be undertaken as an integral part of project development and execution. These steps, which are described in Appendix A, are only necessary if the Philippines and/or the project developer wish to generate carbon credits from the project. While no demand for credits is known to exist today, this may change in the future, making project validation and registration a valuable and worthwhile undertaking.

6.2. Implementation of Phase II and Phase III

Beyond the near-term destruction of ODS stockpiles that are currently in their possession, the Philippines government should also plan for the future management of unwanted ODS. As discussed previously, in addition to the future stream of confiscated stockpiles and mixed refrigerant coming from service industries, there is opportunity to collect ODS from chillers and other refrigerated appliances at end-of-life. Establishing processes now to collect, track, and destroy ODS from these sources will not only prevent harmful venting of these gases to the atmosphere, but will also maximize potential revenue from future destruction projects.

As laid out in this report, the feasibility of financing the destruction of ODS is dependent on the state of the carbon market, which is constantly evolving. New platforms or markets may become available in the future for A5 ODS destruction projects. Additionally, the demand for and price of carbon credits from destruction projects is also likely to increase, making ODS destruction projects less risky and more profitable. Furthermore, opportunity to generate credits from the destruction of other high-GWP greenhouse gases (e.g., HCFCs and HFCs), which are currently not eligible under existing offset protocols, is also expected.

In short, while there are a number of variables that will affect the cost and profitability of ODS destruction in the future, by developing systems now to recover, collect, track, and store ODS from all sources, the Philippines government will be well-positioned to capitalize on future opportunities.

7. References

Air-Conditioning, Heating, and Refrigeration Institute (AHRI). 2009. *Containers for Recovered Non-Flammable Fluorocarbon Refrigerants*. Available at:

http://www.ahrinet.org/App_Content/ahri/files/Guidelines/AHRI%20Guideline%20K-2009.pdf

Air-Conditioning, Heating, and Refrigeration Institute (AHRI). 2012. *2012 Guideline for Assignment of Refrigerant Container Colors*. Available at:

http://www.ahrinet.org/App_Content/ahri/files/Guidelines/AHRI%20Guideline%20N-2012.pdf

Climate Action Reserve. 2013a. Project Database. Available at:

<https://thereserve2.apx.com/myModule/rpt/myrpt.asp?r=111>.

Climate Action Reserve. 2013b. Frequently Asked Questions: Accounts on the Reserve. Available at:

<http://www.climateactionreserve.org/resources/faqs/>.

Climate Action Reserve. 2013c. Submit and Register a Project. Available at:

<http://www.climateactionreserve.org/how/projects/register/>.

Climate Action Reserve. 2012. *Article 5 ODS Project Protocol, Version 2.0*. June 27, 2012. Available at:

http://www.climateactionreserve.org/wp-content/uploads/2010/02/A5_ODS_Project_Protocol_V2.0_Package_041113.pdf.

Ecosystem Marketplace. 2013. *Maneuvering the Mosaic: State of the Voluntary Carbon Markets 2013*.

ICF International. 2009. *ODS Destruction in the United States of America and Beyond*, prepared by ICF International for the U.S. Environmental Protection Agency. May 2009. Available at:

http://ozone.unep.org/Data_Reporting/USA-Decision-XX-7-ODS-Destruction.pdf.

ICF International. 2010. *Study on Financing the Destruction of Unwanted Ozone-Depleting Substances through the Voluntary Carbon Market*, prepared by ICF International for the World Bank. February 2012.

The Multilateral Fund (MLF). 2009. *Study on Financing the Destruction of Unwanted Ozone-Depleting Substances through the Voluntary Carbon Market, Draft Report*. Prepared by ICF International for the World Bank. September 2009. Available at:

<http://www.multilateralfund.org/sites/59/Document%20Library2/1/59Inf2.pdf>.

Partnership for Market Readiness. 2013. *Pricing Carbon and Shaping the Next Generation of Carbon Markets*. Available at: https://www.thepmr.org/system/files/documents/PMR_brochure_web.pdf.

Partnership for Market Readiness. 2013. *Indonesia*. Available at:

<http://www.thepmr.org/country/indonesia-0>. Accessed October 14, 2013.

Partnership for Market Readiness. 2013. *Chairs' Summary of the Sixth Meeting of the PMR Partnership Assembly (PA6)*. May 27-28, 2013. Available at:

https://www.thepmr.org/system/files/documents/PA6_Chair's_Summary_0.pdf.

Republic of the Philippines, National Statistics Office. 2012. Household Population of the Philippines Reaches 92.1 Million. August 30, 2012. Available at: <http://www.census.gov.ph/content/household-population-philippines-reaches-921-million>.

Technology and Economic Assessment Panel (TEAP). 2002. *Report of the Task Force on Destruction Technologies*. April 2002. Available at:

http://ozone.unep.org/Assessment_Panels/TEAP/Reports/Other_Task_Force/TEAP02V3b.pdf.

United Nations Environment Programme (UNEP). 2013. *Report on Progress and Experiences gained in Demonstration Projects for the Disposal of Unwanted ODS*. UNEP/OzL.Pro/ExCom/70/54. June 5, 2013.

United Nations Environment Programme (UNEP). 2012a. *Project Proposals: Turkey*. UNEP/OzL.Pro/ExCom/66/48. March 19, 2012.

United Nations Environment Programme (UNEP). 2012b. *Project Proposals: Nigeria*. UNEP/OzL.Pro/ExCom/67/27. June 19, 2012.

United Nations Environment Programme (UNEP). 2011. *Project Proposals: Mexico*. UNEP/OzL.Pro/ExCom/63/42. March 9, 2011.

Verified Carbon Standard (VCS). 2013. *Program Fee Schedule, Version 3.4*. Available at: <http://www.v-c-s.org/sites/v-c-s.org/files/Program%20Fee%20Schedule%2C%20v3.4.pdf>.

Verified Carbon Standard (VCS). 2011. *Recovery and Destruction of ODS from Products, Methodology VM0016, Version 1.0*. Available at: <http://www.v-c-s.org/sites/v-c-s.org/files/Final%20version%20of%20VM0016.pdf>.

Appendix A. Workbook on the Management of Unwanted ODS in the Philippines

Table of Contents

1. Introduction to the Workbook	2
2. Policy and Regulatory Context	2
2.1. International Agreements Governing the Movement of ODS.....	2
<i>The Basel Convention</i>	2
<i>The OECD Decision C(2001)107/Final</i>	3
2.2. Regional Agreements and National Regulations	4
<i>Import and Use Controls</i>	4
<i>Registration Requirements</i>	4
3. National Inventory of Unwanted ODS	5
4. Guidelines for Managing Unwanted ODS	7
4.1. Collection of ODS.....	7
4.2. Consolidation and Storage.....	8
4.3. Transportation	8
4.4. Testing	9
4.5. Destruction	10
5. Project Development	10
5.1. Assessing the Financial Feasibility of an ODS Destruction Project.....	10
5.2. Selecting a Strategy for Project Development	12
5.3. Overview of the Project Development Process.....	13

1. Introduction to the Workbook

The Montreal Protocol on Substances that Deplete the Ozone Layer has been immensely effective at reducing the production and consumption of ozone depleting substances (ODS) worldwide. While the production and consumption of ODS has dramatically diminished, a large amount of ODS still remains in equipment, products, and stockpiles held by country governments as well as industrial and commercial users. Because emissions from ODS banks are not explicitly controlled by the Montreal Protocol, there is significant risk that these ODS will be released to the atmosphere, contributing to both ozone depletion and global climate change.

To prevent emissions of ODS banks, many options have been explored to provide incentives for the destruction of unwanted material. The high global warming potential (GWP) of ODS means that their destruction has the ability to generate significant volumes of carbon credits. Indeed, a study prepared for the World Bank in 2010 found that a significant opportunity exists for financing the destruction of ODS through the voluntary carbon market.⁹ To help countries operating under Article 5(1) of the Montreal Protocol take advantage of this opportunity, this workbook was developed to serve as a general guide on how to manage unwanted ODS held by country governments.

Specifically, this workbook begins with a summary of international agreements that govern the movement of ODS; then provides guidance on how to develop an inventory of unwanted ODS; followed by a description of guidelines for proper handling of unwanted ODS; and finally provides an overview of the project assessment and development process, including strategies for engaging the public and/or private sector in an ODS destruction project. This version of the workbook has been tailored to reflect specific circumstances for the Philippines.

2. Policy and Regulatory Context

2.1. International Agreements Governing the Movement of ODS

There are several international agreements that affect the movement of unwanted ODS between countries. These include the Basel Convention on the Control of Transboundary Movements of Hazardous Wastes and Their Disposal, and the OECD Decision C(2001)107/Final on the Control of Transboundary Movement of Wastes Destined for Recovery Operations. The basic provisions of these agreements are described below.

The Basel Convention

Adopted in 1989 and brought into force in 1992, the Basel Convention on the Control of Transboundary Movements of Hazardous Wastes and Their Disposal (the Basel Convention) was created to control the

⁹ ICF International. 2010. *Study on Financing the Destruction of Unwanted Ozone-Depleting Substances through the Voluntary Carbon Market*, prepared by ICF International for the World Bank. February 2012.

movement of hazardous waste between countries, particularly the transfer of hazardous waste from developed to developing countries.¹⁰ Currently there are 180 Parties to the Convention.¹¹

Under the Basel Convention, ODS are included in the definition of hazardous waste.¹² As a result, any transboundary movement of unwanted ODS for the purpose of destruction must comply with provisions of the Convention. These provisions prohibit the shipment of hazardous wastes between Parties without prior written consent from the proposed State of import. In addition, Parties may only transport hazardous waste to/from non-party countries¹³ if they have entered into a bilateral, multilateral, or regional agreement that provides for procedures that are as environmentally-sound as those provided under the Convention.¹⁴

Parties to the Basel Convention must also ensure that hazardous and other wastes are managed and disposed of in an environmentally-sound manner. To achieve this goal, Parties must minimize the movement of hazardous waste across borders. Parties may only move hazardous wastes across borders if the State exporting hazardous waste lacks the necessary facilities, capacity, or suitable disposal sites to dispose the waste in an environmentally sound and efficient manner.

The OECD Decision C(2001)107/Final

In 2001, the Organisation for Economic Co-operation and Development (OECD) decided to regulate the international movement of wastes through decision C(2001)107/Final. Under this OECD decision, member countries can control transboundary movements of wastes destined for recovery operations, and recovery facilities must recover wastes in an environmentally-sound manner, in accordance with national regulations. CFCs and halons are subject to the Amber control procedure, which requires strict documentation for transboundary movement of wastes throughout the entire process, starting with the exporter and ending with the recovery facility. When transboundary movement or recovery operations

¹⁰ The Basel Convention on the Control of Transboundary Movements of Hazardous Wastes and their Disposal, Texts and Annexes, *available at* <http://www.basel.int/Portals/4/Basel%20Convention/docs/text/BaselConventionText-e.pdf>.

¹¹ Secretariat of the Basel Convention (2013), Parties to the Basel Convention, accessed June 2013, *available at* <http://www.basel.int/Countries/StatusofRatifications/PartiesSignatories/tabid/1290/Default.aspx>.

¹² ODS fall under the Convention's categories Y41 (Halogenated organic solvents) and Y45 (Organohalogen compounds other than substances referred to in the Annex).

¹³ Non-party countries include: Angola, Fiji, Grenada, Haiti, Myanmar, Sao Tome and Principe, Sierra Leone, Solomon Islands, South Sudan, Timor-Leste, Tuvalu, United States, and Vanuatu. Source: <http://www.basel.int/Countries/StatusofRatifications/PartiesSignatories/tabid/1290/Default.aspx>.

¹⁴ Multilateral Fund (2006), Report of the Meeting of Experts to Assess the Extent of Current and Future Requirements for the Collection and Disposition of Non-Reusable and Unwanted ODS in Article 5 Countries (Follow up to Decision 47/52). 20 March 2006.

cannot be completed as planned, the exporter or importer must provide financial guarantees for the environmentally-sound management of the wastes.¹⁵

2.2. Regional Agreements and National Regulations

In addition to the international agreements described above, regional agreements and national regulations govern the movement of ODS. As a signatory of the Montreal Protocol, the Philippines has developed domestic policies to monitor and limit consumption of ODS to meet ODS phase-out targets that are established by the Parties to the Montreal Protocol. Since ODS are not produced in the Philippines, these regulations primarily govern the import and sale of ODS. An overview of these regulations is described below.

Import and Use Controls

Republic Act #6969, known as the "Toxic Substances and Hazardous and Nuclear Wastes Control Act of 1990" regulates, restricts, or prohibits the importation, manufacture, processing, sale, distribution, use, and disposal of chemical substances and mixtures that present unreasonable risk and/or injury to health or the environment. In addition, the Act prohibits the entry, even in transit, of hazardous and nuclear wastes and their disposal into the Philippine territorial limits for whatever purpose, and provides advancement and facilitates research and studies on toxic chemicals. Under this Act, the Filipino government has the authority to monitor and regulate imports of ODS.

Through a regulation called the Chemical Control Order (CCO) for Ozone Depleting Substances, the Filipino government established import controls and a phase-out schedule for all substances listed under Annex A, Annex B, and Annex C of the Montreal Protocol. Substances listed under Annex E (i.e., methyl bromide) are regulated by the Fertilizer and Pesticide Authority of the Department of Agriculture and therefore are not subject to the controls identified in the CCO. A freeze on the consumption of Annex A, Group I chemicals at the 1996-estimated consumption level was first implemented in the Philippines in 1999. Annual quotas for subsequent years were established as a percentage of the baseline quantity in accordance with the Montreal Protocol phase-out schedule. The quotas are non-cumulative and are forfeited at the end of each year if not used. Prior to the 2010 phase-out of CFCs, annual import quotas were set for each importing company. While no import quotas have been established for HCFCs under the CCO, a clearance from the government is required for import of these substances.

Registration Requirements

Registration is required in order to import any substances controlled under the CCO into the Philippines. In addition to importers, dealers, retailers, and re-sellers of ODS must also register in order to determine

¹⁵ OECD, Decision of the Council concerning the Transboundary Movements of Wastes Destined for Recovery Operations, C(2001)107/FINAL, June 2001, available at <http://acts.oecd.org/Instruments/ShowInstrumentView.aspx?InstrumentID=221&InstrumentPID=217&Lang=en&Book=False>.

their capability in handling and using these substances. Such registration is on an enterprise and site-specific basis. Pending the enactment of the April 2011 draft revised Chemical Control Order to Ozone Depleting Substances, exporters of ODS and service providers of ODS-using equipment will also be required to register.

3. National Inventory of Unwanted ODS

Banks of unwanted ODS commonly reside in stockpiles and retired equipment that are largely owned or in the possession of government agencies and private companies. As a first step to managing these banks, an inventory detailing the quantity, type, purity, location, and ownership of the material must be developed. This inventory can be developed through a variety of actions, including compilation of records from Customs and/or other government agencies as well as by conducting an assessment of stockpiled material through site visits to storage facilities. The installed base of equipment containing ODS may also be compiled through input from end-users and industry. The approach used will depend on the quality and robustness of data tracking systems that are already in place within the country.

When compiling the information, unwanted ODS in stockpiles and in equipment should be inventoried separately. For ODS in equipment, countries may wish to focus on inventorying equipment with larger ODS charge sizes, such as chillers, which often present more cost-effective opportunities for destruction.

To assist in the development of an ODS inventory, an Excel-based inventory tool may be used, as provided as an attachment to this workbook. The tool should be populated following an assessment of the stockpiles and equipment that reside in your country. Guidance for how to populate the tool is provided below along with example screenshots from the inventory tool:

Eligibility

While only CFCs and other phased-out ODS are currently eligible under ODS destruction protocols in the voluntary carbon market, it is expected that the destruction of next-generation refrigerants such as HCFCs (and HFCs) will eventually be eligible for carbon credits, and thus inventorying all substances can support future projects.

- ❖ **Stockpiles:** For each cylinder, fill out one row indicating the serial number, manufacturer, location, and size of the cylinder, as well as the type(s) of chemicals contained, including CFCs, HCFCs, and HFCs. If multiple chemicals are mixed in cylinder, specify each type of chemical, if possible. Other data elements may also be collected, such as the tare weight of the cylinder and the total weight of the cylinder, including its contents.

Stockpile Inventory

Instructions: For each cylinder, fill out one row indicating the serial number and manufacturer of the cylinder, the location (facility name, street address, and city), the size of the cylinder (in kilograms), and the type(s) of chemicals contained, including CFCs, HCFCs, and HFCs. If multiple chemicals are mixed in cylinder, please indicate each type.

Stockpile ID #	Cylinder Serial Number	Cylinder Manufacturer	Facility Name	Street Address	City	Cylinder Size (kilograms)	Chemical Type
S1							
S2							
S3							
S4							
S5							
S6							
S7							
S8							
S9							

- ❖ **Chillers:** For each chiller, fill out one row indicating the location of the chiller, the chiller type, the cooling capacity, the type of refrigerant contained (including CFCs, CTC, methyl chloroform, HCFCs, HFCs), and the refrigerant charge size.

Chiller Inventory

Instructions: For each chiller, fill out one row indicating the location of the chiller (facility name, street address, and city), the chiller type (reciprocating, scroll, screw, or centrifugal), the cooling capacity (in tons), the type of refrigerant contained (including CFCs, HCFCs, and HFCs), and the refrigerant charge size (in kilograms).

Chiller ID #	Name of Facility Holding Chiller	Street Address	City	Chiller Type	Cooling Capacity (Tons)	Refrigerant Type	Refrigerant Charge Size (Kilograms)
C1							
C2							
C3							
C4							
C5							
C6							
C7							
C8							
C9							

- ❖ **Other Equipment:** For each piece of equipment, fill out one row indicating the location of the equipment, the equipment type (e.g., dehumidifier, refrigerator/freezer), the type of refrigerant contained (including CFCs, HCFCs, and HFCs), the refrigerant charge size, the substance in foam (including CFCs, HCFCs, and HFCs), if applicable, and the mass of the substance in foam.

Other Equipment Inventory

Instructions: For each piece of equipment, fill out one row indicating the location of the equipment, the equipment type (e.g., dehumidifier, refrigerator/freezer), the type of refrigerant contained (including CFCs, HCFCs, and HFCs), the refrigerant charge size, the substance in foam (including CFCs, HCFCs, and HFCs), and the mass of the substance in foam.

Equipment ID #	Name of Facility Holding Equipment	Street Address	City	Equipment Type	Refrigerant Type	Refrigerant Charge Size (Kg)	Substance in foam	Mass of Substance in Foam (Kg)
E1								
E2								
E3								
E4								
E5								
E6								
E7								
E8								
E9								

Once the inventory tool is populated, the summary tables will auto-complete, showing total quantities of unwanted ODS held domestically to enable further analysis about the financial feasibility of destruction projects.

Inventory Summary

Inventory Type	Stockpile Inventory (kg)	Stockpile Inventory (MTCO ₂ e)	Chiller Inventory (kg)	Chiller Inventory (MTCO ₂ e)	Other Equipment Inventory (kg)	Other Equipment Inventory (MTCO ₂ e)
CFC-11						
CFC-12						
CFC-114						
HCFC-22						
HCFC-123						
HCFC-124						
HCFC-141b						

4. Guidelines for Managing Unwanted ODS

The general process toward ODS destruction involves collection, consolidation and storage, transport, testing, and final disposal, as illustrated below. In each step of this process, best practices for handling unwanted ODS must be followed to ensure eligibility for carbon offsets under existing carbon markets. Currently, two major platforms in the voluntary carbon market are crediting for ODS destruction projects: the Climate Action Reserve (the Reserve) and the Verified Carbon Standard (VCS).¹⁶ Some countries may also have national carbon markets that allow for crediting for ODS destruction projects; this potential will be assessed in country-specific workbooks. A description of the requirements identified in the Reserve and VCS methodologies is provided below.

The Process of ODS Destruction

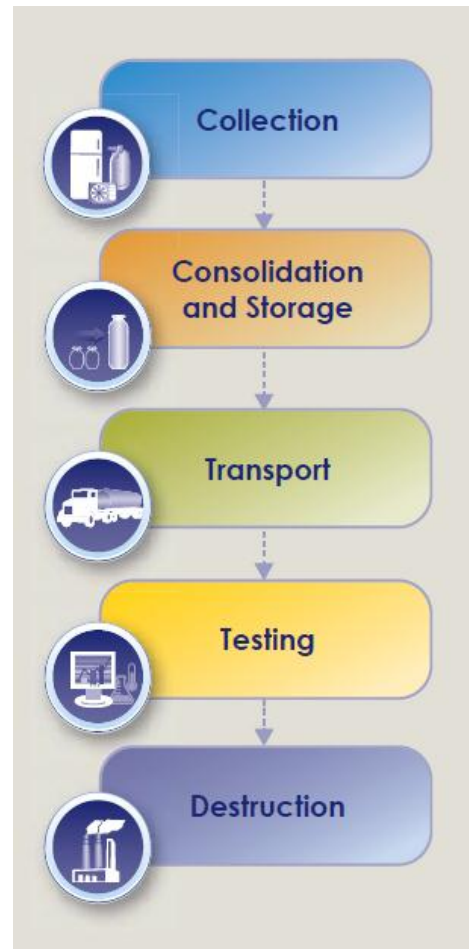

4.1. Collection of ODS

As previously discussed, unwanted ODS is most commonly found in stockpiles and decommissioned equipment. Guidelines to follow when collecting this material include:

- ❖ ODS should be collected, stored, and transported in cylinders or other hermetically sealed containers.
- ❖ Removal of refrigerant from commercial/industrial equipment at end-of-life should be conducted on site by certified technicians. Refrigerator cabinets may be shredded whole and steam-treated in an airtight chamber to recover ODS blowing agents or the foam may be removed and treated separately.

¹⁶ The Reserve’s Article 5 ODS Project Protocol; Approved VCS Methodology VM0016: Recovery and Destruction of ODS from Products

- ❖ The point of origin and date of establishment must be documented for each quantity of ODS. For stockpiles, the point of origin is the location of the stockpile.¹⁷ For ODS recovered from equipment at end-of-life, the point of origin is the location where the ODS was recovered from the equipment. Records should be kept including the facility name, address, and serial or ID number of the containers used for storage and transport.

Custody and Ownership

Throughout the entire process, it is critical to properly document the chain of custody. Carbon credits will not be issued unless ODS ownership can be properly established; therefore, all records that show previous ownership of the material and transfer of that ownership to the project developer should be maintained. For VCS, the chain of custody must be documented by paper bills of lading or electronic, third-party tracking that includes proof of delivery. Other forms of documentation are accepted by the Reserve, including purchase orders or agreements, packing lists, lab test results, transfer container information, receiving inspections, freight bills, transactional payment information, or other supporting information.

4.2. Consolidation and Storage

Because ODS might be collected from a large number of smaller units (such as household refrigerators or small cylinders), it needs to be combined before sending it for destruction; this step avoids the shipping of many smaller containers, which can lead to additional expense, possible damage and leakage, and other obstacles. Collected ODS is typically brought to a central facility, where it is consolidated into larger cylinders or storage tanks, and stored until a quantity sufficient for destruction has been aggregated.

4.3. Transportation

In this step, the ODS is transported to a destruction facility by truck, rail, or ship. The ODS may be transported several times before its ultimate destruction, often as it moves through the consolidation process.

Per the Code of Good Housekeeping approved by the Montreal Protocol, to ensure that ODS does not constitute an unnecessary risk in transportation, shipments must be properly packaged and labeled. Instructions to be followed in the event of danger or accident must accompany each shipment to protect human beings and the environment from any danger that might arise during the operation. Notification of the following information should be provided at any intermediate stage of the shipment from the place of dispatch until its final destination: (a) the source and composition of the ODS and products containing ODS, including the customer's identity; (b) arrangements for routing and for insurance against damage to third parties; (c) measures to be taken to ensure safe transport and, in particular, compliance by the carrier with the conditions laid down for transport by the States concerned; (d) the identity of the consignee, who should possess an authorized centre with adequate

¹⁷ The date on which a quantity of ODS was "stockpiled" is defined by the Reserve as the furthest date in the past on which the quantity of ODS contained in the reservoir was greater than or equal to the total quantity of all ODS removed from the reservoir since that date.

technical capacity for the destruction; and (e) the existence of a contractual agreement with the consignee concerning the destruction of ODS and products containing ODS.

To remain eligible for carbon credits, all import activities must be conducted in full compliance with the regulations of the country in which ODS is to be destroyed, and must have a complete import record. Under the Reserve, ODS must be imported into the United States for destruction, and full documentation of this process, including all petition and record-keeping documents, must be retained and provided for verification.

4.4. Testing

After arrival at the destruction facility, but before the material is destroyed, testing of the container contents is undertaken to verify exactly what materials are being destroyed, often through gas chromatography. The Reserve and VCS have similar methodologies that must be followed for determining the precise mass and composition of ODS to be destroyed, as briefly described below. Responsibility for following these methodologies is generally borne by the project developer.

First, the mass must be determined. Specific requirements for measuring the weight of the container can be found in each methodology. Second, the composition and concentration of ODS and contaminants must be established for each individual container. A sample from each container of ODS must be analyzed for composition and concentration at a lab accredited to perform analyses in compliance with the applicable International Organization for Standardization (ISO) standard or at an Air-Conditioning, Heating and Refrigeration Institute (AHRI) certified laboratory using the AHRI 700-2006 standard. The laboratory performing the composition analysis must not be affiliated with the project developer or the project. Specific requirements must be met for each sample, as described in detail in the methodologies, and analysis of the samples should provide:

1. Identification of the refrigerant;
2. Purity (%) of the ODS mixture by weight using gas chromatography;
3. Moisture level in parts per million. The moisture content of each sample must be less than 75% of the saturation point for the ODS based on the temperature recorded at the time the sample was taken;
4. Analysis of high boiling residue, which must be less than 10% by mass; and
5. Analysis of other ODS in the case of mixtures of ODS, and their percentage by mass.

For containers holding mixed ODS, a separate process must be followed. This process includes determination of the composition and concentration of ODS on a mass basis, followed by circulation of the mixed ODS and then sampling and analysis.

4.5. Destruction

For both the Reserve and VCS, destruction of ODS must occur at a facility that meets all guidelines provided in the UNEP Technology and Economic Assessment Panel (TEAP) Task Force on Destruction Technologies. In addition, under the Reserve, destruction facilities must be located in the United States and meet requirements of U.S. domestic law.

While destroying ODS material, operating parameters of the destruction unit must be monitored and recorded in accordance with each of the methodologies and the Code of Good Housekeeping approved by the Montreal Protocol. Like for testing, responsibility for following these methodologies is generally borne by the project developer.

How long does an ODS destruction project take?

Once the project has been identified, it can take from about one year to several years from project development through to sale of the credits. The timeframe depends on a variety of factors including the complexity of the project, the type or design of the project (e.g., some projects are designed to be implemented over several years, such as an on-going refrigerator collection program), and many other factors, some of which can be influenced by the project developer and some which cannot.

5. Project Development

Because the Kyoto Protocol limits trading to non-Montreal Protocol greenhouse gases, ODS are currently not eligible for projects under the Clean Development Mechanism. Instead, ODS destruction is eligible to earn carbon credits in the voluntary carbon market, where organizations can offset carbon emissions on a voluntary basis. In the voluntary carbon market, two major third-party standards are offering credits for ODS destruction projects: the Verified Carbon Standard (VCS) and the Climate Action Reserve (the Reserve).¹⁸ In addition, some countries may have national carbon trading systems or GHG emission reduction targets that may allow for ODS destruction projects to fulfill national requirements.

The sections below describe considerations for assessing the financial feasibility of an ODS destruction process and for engaging with the private sector for project development, followed by an overview of the general project development process.

5.1. Assessing the Financial Feasibility of an ODS Destruction Project

Before initiating the project development process, a preliminary assessment of the cost-effectiveness of the project should be considered.

The overall cost of developing an ODS destruction project includes the costs of collection, transportation, storage, testing, and destruction, as well as the “transaction” costs of project

¹⁸ While technically there is no strict requirement to operate in accordance with a third-party standard, end consumer requirements are driving demand for projects developed using recognized third party standards. In 2008, 96 percent of transacted VERs was verified by a third-party standard.

preparation, validation, and verification.¹⁹ Project costs vary widely depending on many factors such as geographical location, nature of ODS bank and the effort required to recover the ODS, quantity of ODS being handled, technologies used, type of ODS, firms contracted, and demand for services. In general, some projects may be more costly than others to develop. For example, collecting used CFCs from household refrigerators is likely to be more costly than recovering ODS from commercial air conditioning equipment with large charge sizes, on a per kilogram of ODS basis. Destroying existing ODS stockpiles may be the most cost-effective project type.

Because some project costs are “fixed” (i.e., they do not vary depending on the amount of ODS destroyed), destroying larger volumes of ODS can lead to higher profitability. In particular, project transaction costs—such as the cost of project preparation, verification, etc.—must be incurred regardless of the amount of ODS destroyed. Additionally, some project implementation costs may also be realized irrespective of the amount of ODS collected and destroyed. For example, setting up the infrastructure for a refrigerator collection program may be a one-time cost that does not depend heavily on the number of refrigerators collected. These “fixed” costs mean that in some cases there may be a minimum amount of ODS that must be destroyed in order to have a financially viable project.

To assist with the financial assessment, a simple Excel-based financial tool may be used, as provided as an attachment to this workbook.

The profitability of the project will also strongly depend on the trading price of carbon credits verified by each third-party standard, and the attractiveness of ODS destruction credits to buyers. Demand in the voluntary market is driven not by regulation but by buyers’ interest in mitigating and offsetting their emissions—which is often motivated by reputational considerations. As such, ODS projects need to be packaged in a way that is attractive to buyers and their stakeholders. In particular, ODS project proponents may need to differentiate themselves from other industrial gas projects that have drawn criticism (and lower carbon prices) in the past, such as HFC-23 destruction. A good solution here is for ODS destruction projects to tell a compelling story emphasizing that they help pay for the removal of GHGs that would otherwise be emitted over time if left unaddressed.

From the sellers’ side of the market, uncertainty about carbon prices will be an ongoing challenge that is inherent to the carbon market. Prices depend on a variety of factors, including the standard to which the project is developed, the

What are some strategies to minimize costs?

- Combine ODS destruction projects with other activities or programs that are also eligible for crediting in the carbon market, such as equipment replacement for energy efficiency credits. This strategy could be effective to fund ongoing collection programs, such as municipal, utility, or retailer programs to collect refrigerators on disposal, and ensure that ODS refrigerant and foam blowing agent is destroyed.
- Mainstream ODS destruction projects into larger programs and development projects, such as country ODS phaseout programs or a comprehensive waste management program.
- Group or pool projects to minimize transaction costs and achieve economies of scale.

¹⁹ Most of these costs are likely to be borne by the project developer (or the project financier), although some upfront costs—such as those to maintain ODS stockpiles in advance of project development—are usually borne by the owner of the ODS.

perceived robustness of the methodology used, and so on. In the past, low prices on the Chicago Climate Exchange (CCX) market have contributed to decisions not to move forward with an ODS destruction project, such as in the case of Argentina, where some CTC was instead sold to Mexico for feedstock use rather than destroyed in the U.S. for crediting under CCX. If project developers are uncertain about whether a project will earn a profit, it may not be pursued. Prices for the over-the-counter market are not generally disclosed publicly but are available indirectly through several sources, including an annual report published by Ecosystem Marketplace and New Carbon Finance (available on www.ecosystemmarketplace.com).

5.2. Selecting a Strategy for Project Development

Once the decision is made to pursue an ODS destruction project, several options for structuring private-public financing arrangements are available for government agencies in possession of unwanted ODS. These options include:

- ❖ **Contracting Out**—The process is managed by a private sector entity with the Government informing the public of potential revenue streams from ODS disposal and issuing appropriate documentation required for disposal or export for final disposal. Under this option, ownership of the ODS would be transferred to a private entity, who would then develop an ODS destruction project, and all project revenues would be owned by the private entity. That said, some revenues may still accrue to the Government, if, for example, a Government chose to sell its ODS stockpile via an auction process. This option has the lowest administrative and cost burden on the Government.
- ❖ **Facilitation**—The Government plays a modest administrative role and exercises its regulatory responsibilities while working in concert with a private sector project developer to facilitate the chain of identification, inventory development, collection, licensing, auctioning, registering and collecting/transferring revenues to the Government. Under this option, the Government would need to identify and hire a project developer to develop the project on its behalf, as well as negotiate ownership of the final credits earned. In some arrangements, ownership of these credits is fully transferred to the owner of the ODS; in other arrangements, ownership of the credits is shared between the project developer and owner of the ODS.
- ❖ **Project Developer**—In this option, a Government entity assumes responsibility for creating the emission reduction credits by managing and generating credit through the chain of activities identified above in order to generate and collect carbon revenues for the Government. This option has the highest administrative burden for the Government, and requires the Government entity to have significant capacity and experience in the voluntary carbon market, and to be able to cover upfront project development costs and market the credits, in anticipation of future revenues. While no rules restrict governments from acting as project developers, there is also no clear precedent for national government participation in the project development side of the voluntary market. Generally, government roles have tended to focus on facilitating market intervention through capacity building and legislation, although there is some experience with

governments serving as the project developer and coordinating entity for a programme of activities through CDM. If a national carbon trading system accommodates ODS destruction projects, however, the hurdle may be lower for Government entities serving in a project developer role.

Under the first two options identified above, the Government can rely on a private sector entity to guide it through the project development process, as described in the next section. To initiate this engagement, however, a Government must identify and contract with a private sector entity. This procurement process must be undertaken in accordance with national rules and regulations. Some strategies for identifying potential private sector partners are described in the textbox to the right.

How do I identify potential private sector partners?

- Review ODS destruction projects that have been registered under the Reserve and VCS to identify the associated project developer.
- Review carbon registries with projects in related areas to identify associated project developers. These related projects could include energy efficiency and leak detection projects under the CDM and VCS, such as the following protocols: VM0001, AM0060, AM0070, AM0071, AMS-III.X, and AMS-II.C.
- Consider private entities located in-country with ODS destruction capabilities—such as cement kilns.

5.3. Overview of the Project Development Process

Whether led by a private sector project developer—or a Government entity acting as project developer—the development of a voluntary project generally follows a number of broad steps, as shown in the figure below.

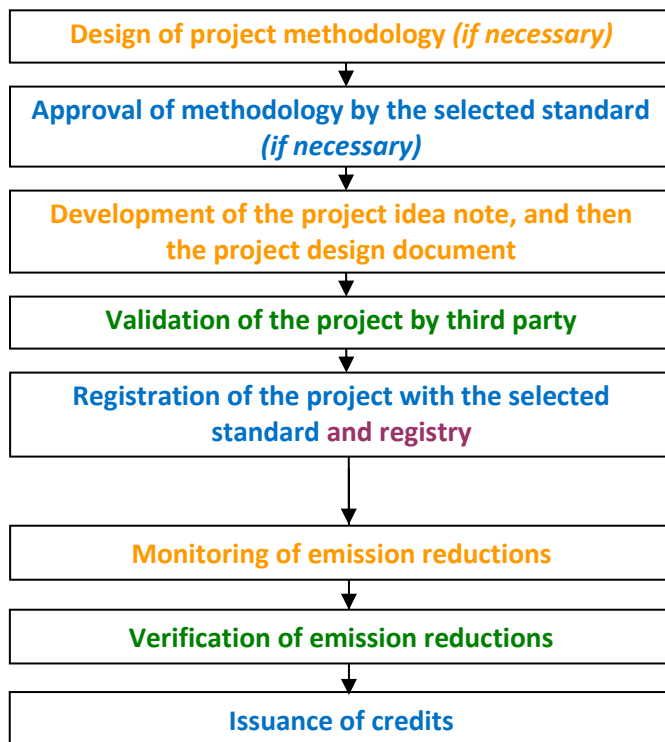

Developing a voluntary project involves a number of generic steps regardless of the specific standard being pursued. Different stakeholders specific to the project cycle are:

- **Project developer**
- **Verifier:** third party in charge of assessing compliance of the project with the rules of the standard pursued
- **Standard:** the specific authority that officially registers the project and issues credits
- **Registry:** a system for creating, tracking, trading and retiring carbon credits

The broad steps that the project developer could take towards developing an ODS destruction voluntary project are further described below.

1. Review voluntary market third-party standards and existing methodologies for selection.

A project developer would first review the available standards to identify which one meets the needs of the envisioned ODS destruction project (e.g., given the standard's rules, geographical coverage, and so on). For example, currently the Reserve limit eligible projects to those that destroy ODS in the United States; if national regulations make it difficult to move ODS transnationally, the Reserve may not be a viable option.

Currently, one protocol exists for ODS destruction under the Reserve (*Article 5 ODS Project Protocol Version 2.0*), and one exists under VCS (*VM0016*). If one of these methodologies is appropriate for the project in question (e.g., the envisioned project seems eligible under the methodology, the methodology seems "doable"), then the project developer can move on to the next step. If this is not the case, however, then the project developer generally has two options:

- ❖ Seek a revision or deviation to an existing methodology (if allowed), or
- ❖ Develop a new methodology for submission and approval by the third-party standard that is being pursued (if the standard accepts new methodologies).

If neither option is possible, then the project developer cannot move forward under the standard selected.

2. Develop a project idea note.

Once a methodology is selected (or approved), the project developer usually develops a project idea note (PIN). A PIN is not required by the third-party standards, but is often used to attract financing for a project. A PIN describes the project and sets out the business case for the voluntary credit project, as well as the additionality case. It sets out if an existing methodology is applicable to the project or whether a new methodology needs to be developed. It also presents the likely costs, expected number of credits the project would produce, the voluntary standard that would be sought, and the potential revenue that the sale of the credits could generate.

Depending on the level of in-house expertise, this, and other project documentation and support, may be undertaken by an external consultant.

3. Establish funding.

The project developer has two main options for financing:

- ❖ Funding the entire project activity itself with a view to selling the credits once the project is registered and the credits are issued or

- ❖ Using the PIN to attract interest from a financier. A financier could provide the capital required to support the project through the cycle and fund the destruction process in return for more favorable credit prices, or could support just the carbon costs of the project.

4. Develop full project documentation.

Once financing is in place, the full project documentation (i.e., the project design document or its equivalent, as defined by the third-party standard, describing the emission reduction activity) would be developed and the validation process would begin (if required).

5. Monitor and verify emission reductions, and receive credits.

Next is the annual monitoring and verification of emission reductions generated by the project by an external auditor. The project developer generally engages a third-party verifier to certify the validity of the project's emissions reductions. Upon receipt of a completed verification report, the selected registry issues the credits.

6. Obtain validation.

If required by the third-party standard, the project documentation is also submitted for validation. If successful, the project is then registered under the selected standard. This step is not required for the Reserve.

7. Market the credits.

Depending on the arrangements with the financier, the credits would pass to the owner, or be shared between the owner and the developer, as negotiated. Project developers may then sell offsets through brokers to aggregators or final customers (e.g., companies or consumers looking to voluntarily offset their emissions). Developers may also sell to aggregators directly or onto an exchange.

Verification Process

Verification of emission reductions is a critical step in the project development process that includes the following:

- Testing Internal Controls
- Conducting Substantive Testing
- Data Validation
- Aberrant Data
- Reasonable Assumptions, Methodologies, and Calculations

As such, this process should be undertaken by a credible third-party to ensure validation.

Appendix B. Importance of Evaluation Criteria Relative to Financing Options

Evaluation Criteria	Importance for the Viability of Financing Options		
	National Carbon Market	VCS	The Reserve
Required Criteria			
National carbon market has been established or is under development	Required	NA	NA
No national capacity for ODS destruction exists AND there are no national regulations currently in place that limit the export of ODS	Required	Required	NA
The anticipated market price of the ODS destruction credits will be high enough to cover projected project costs	NA	Required	Required
There are no national regulations currently in place that limit the export of ODS	NA	NA	Required
Preferred Criteria			
The country is a participant in PMR Program	Highly Preferred	NA	NA
National capacity for ODS destruction exists	Highly Preferred	Preferred	NA
Regional capacity for ODS destruction exists	Preferred	Highly Preferred	NA
Regional or national capacity for ODS destruction has a removal efficiency of at least 99.9999 percent	NA	Highly Preferred	NA
Project developers have shown interest in developing an ODS destruction project with the material sourced from the Philippines	Preferred	Highly Preferred	Highly Preferred

Appendix C. Potential Project Developers

The following list of project developers identifies companies that either have direct experience developing ODS destruction projects or have other relevant experience developing regional projects under the Reserve and/or VCS. While not an exhaustive list, the following companies are considered to be the most likely to undertake development of an A5 ODS destruction project for the Philippines.

A-Gas RemTec
1100 Haskins Road
Bowling Green, OH 43402 USA
1-800-372-1301

COOLGAS, INC.
30045 FM 2978
Magnolia, TX 77354 USA
1-800-366-1356

Diversified Pure Chem, LLC
11050 South Highway 287
Rhome, TX 76078
817-636-2089
sales@divpc.com

Emergent Ventures India (EVI)
5th Floor, Universal Trade Tower
Gurgaon- Sohna Road, Sector 49
Haryana, India, 122018
+91-124-6653100
contact@emergent-ventures.com

Environmental Credit Corp.
210 W. Hamilton Ave #297
State College, PA 16801 USA
607-288-4020
info@envcc.com

EOS Climate Inc.
55 Hawthorne St, Suite 610
San Francisco, CA 94105 USA
800-764-8093
info@eosclimate.com

OEKO Service Luxembourg (O.S.L.) S.A.
Zone Industrielle Piret, B.P. 43
7737 Colmar-Berg, Luxembourg
+352488216-1

RapRec Refrigerants
8971 W. Bloomfield Rd.
Peoria, AZ 85381
877-372-7732

Refrigerant Exchange Corp.
5263 N. 4th St.
Irwindale, CA USA
626-338-1890
info@refex.com

South Pole Carbon
2/22 Iyara Building, 6th Floor
Chan Road, Soi 2, Thungwatdorn
Sathorn, Bangkok 10120 Thailand
+ 66 2 678 89 79
info@southpolecarbon.com

Appendix D. Sample Terms of Reference for Project Developer



UNITED NATIONS INDUSTRIAL DEVELOPMENT ORGANIZATION

DEMONSTRATION PROJECT FOR DISPOSAL OF UNWANTED ODS IN MEXICO (MP/MEX/11/003 and TE/MEX/12/004)

TERMS OF REFERENCE

FOR THE SUPPLY OF SERVICES REQUIRED FOR THE DESTRUCTION OF UNWANTED ODS COLLECTED IN MEXICO

11th March 2013

I. GENERAL BACKGROUND AND OBJECTIVES

The 63rd Meeting of the Executive Committee of the Multilateral Fund for the Implementation of the Montreal Protocol (4 – 8 April 2011) approved funding for the demonstration project on ODS destruction in line with decision 58/19, to be implemented by UNIDO and the Government of France.

The objective of this project is to destroy 166.7 metric tons of unwanted ODS in the refrigeration sector in Mexico collected during the past 8 years: it includes all categories of activities for the disposal of ODS, namely transport, storage and destruction.

The estimated project impact reflects a total reduction of greenhouse gas emission of 997,110 tons of CO₂-equivalents.

Since 2005 the Government of Mexico through the Ministry of Energy and Energy Saving Fund (FIDE) has successfully accelerated the replacement of old refrigeration appliances with new energy efficient equipment. In 2007, the Secretariat of Environment and Natural Resources (SEMARNAT) and UNIDO, throughout the National CFC Phase out Plan, trained and equipped 100 collecting Centers (FIDE centers) with tools to identify and recover refrigerants gases from old appliances dismantled in these centers. In 2009, FIDE established the second phase of the program for the substitution of domestic refrigerators with the goal to replace and collect 1,600,000 appliances until the end of 2012; the new phase includes 110 collecting centers.

On the other hand, in 2007 SEMARNAT and UNIDO installed a network of 14 recycling centers within Mexico in order to provide recovery, recycling and storage for destruction services to the refrigeration technicians and companies involved in the refrigeration sector.

As of February 2013, the currently available stocks for destruction come from these two collection programs. Additionally, two pharmaceutical companies have remaining stocks of virgin CFC ready to send for destruction.

II. OFFER REQUIREMENTS

This Terms of Reference should be used for the preparation of a proposal to supply services required for the collection, transport and destruction of 74.1 tons of unwanted ODS.

The destruction of unwanted ODS must be carried out in compliance with the technologies approved by the Technology and Economic Assessment Panel of Montreal Protocol (TEAP - *Report of the Task Force on Destruction Technologies*; http://ozone.unep.org/teap/Reports/Other_Task_Force/index.shtml) and meet the performance parameters and emissions requirements set out by TEAP, as well as comply with the applicable local regulations.

The contract awarded company is required to carry out the transport for collection in order to consolidate all the quantities of ODS in one collection center which has to have all the permits for the management of this type of gases, including, but not limited to, hazardous waste management, in enough quantities to handle at least 74.1 tons.

If the destruction of ODS will take place outside Mexico, the collection center selected by the awarded company will be responsible for all export procedures, including licenses, allowances, and permits to export the referred ODS.

The collection and destruction of 74.1 tons of unwanted ODS has to be undertaken within one year starting from the date of signature of the contract related to these Terms of Reference. Companies must provide a detailed description of the destruction methods they will apply.

If unwanted ODS are to be destroyed in order to obtain Carbon Credits, destruction has to be carried out through methodologies approved by the Climate Action Reserve (CAR) or the Verified Carbon Standard (VCS). The methodologies taken into consideration must have been approved before the date of publication of the present Terms of Reference on the UNIDO website.

A. Technical Offer

The proposal of destruction services offered must include the following information:

1. General data of the company:
 - Name of the company
 - Address
 - Telephone
 - E- Mail

- web site (if available)
 - Operation records of the company for the last 2 years, demonstrating the experience in the management and destruction of refrigerant gases and/or comparable substances.
 - Listing of qualifications and brief description of experience of the personnel to be assigned to the project.
2. Detailed description of the destruction facility:
- Type of ODS destruction technology approved by TEAP.
 - Location of the facility.
 - Operational procedures.
 - ODS handling and storage including safety procedures for containers and bulk storage tanks for refrigerants.
 - ODS identification and quantification methods applied.
 - Preparation and feeding of gas to the destruction process.
 - Feed rate range (kg/hr) of gas.
 - Emission monitoring system.
 - Treatment of gaseous and aqueous effluents (when applicable).
3. Emission values of the destruction technology:
- Destruction and Removal Efficiency of ODS.
 - Emissions of dioxins and furans.
 - Emissions of acidic gases (HCl and HF), particles and carbon monoxide.
 - Emissions of metals and other relevant pollutants.
4. Information of the Collection Center:
- Name of the Center
 - Address
 - Telephone
 - E- Mail
 - web site (if available)
 - Number of hazardous waste collection registry delivered by SEMARNAT.
 - Number of all environmental authorizations required to get the export permission of recovered ODS.
 - Operation records demonstrating the experience in the management of refrigerant gases and/or comparable substances.
 - Listing of qualifications and brief description of experience of the personnel to be assigned to the project.
5. Information on the Transport Company for the transport of recovered ODS:
- Name of the Transport Company
 - Address
 - Telephone
 - E- Mail
 - web site (if available)
 - Number of all authorizations required for the transport of recovered ODS within Mexican territory.
6. Additional information:

- If ODS are to be destroyed in order to obtain Carbon Credits, proven track record in registering projects under CAR / VCS.

7. Provide a Commitment Letter

B. Commercial Offer

Detailed description of the cost for proposed services:

1. Based upon information in Annex 1, cost for transportation from the points of origin to the destruction facility. The quotation should include the cost of handling and the return of empty containers to the points of origin.
2. Cost for destruction per kg, including temporal storage and handling in the destruction facility.
3. Cost of reporting (reporting requirements are specified in Section V of this Terms of Reference).
4. If a share or the whole of the unwanted ODS are to be destroyed in order to obtain carbon credits, registration cost under one of the two carbon market schemes considered (e.g. validation, monitoring, reporting and verification, etc.)

The proposal must include a detailed time schedule for the destruction of 74.1 metric tons of unwanted ODS. The batches of unwanted ODS (as identified in Annex 1) have to be destroyed in the sequence specified in Annex 2.

Companies are requested to fill the table provided in Annex 2 with an estimation of:

1. Dates when each batch of unwanted ODS will be transported from its collection point (as detailed in Annex 1) to the destruction facility;
2. Dates when each batch of unwanted ODS will be destroyed.

III. LANGUAGE REQUIREMENTS

The personnel provided by the supplier for undertaking the above-defined tasks will be required to have working knowledge of Spanish and English (both written and spoken); the ability to provide native Spanish speakers will be an asset

IV. DELIVERABLES

A. Reporting to the National Ozone Unit of Mexico

Destruction facilities must report on the destruction of each batch of unwanted ODS to the National Ozone Unit of the Government of Mexico. The information provided should include:

1. General Data of the Destruction facility.
2. Name of the Developer.
3. Name of the Generator.
4. Origin of the unwanted ODS.
5. A quantity of unwanted ODS destroyed.
6. Gas composition.
7. Certificate of Destruction - ID number.
8. Serial, tracking, or ID Number of all tanks for which ODS destruction occurred.
9. Destruction dates.

All this information must be registered on line through the Monitoring System provided by National Ozone Unit from SEMARNAT.

B. Reporting to UNIDO

1. The contractor shall submit a Work Plan one month after the signature of the contract. It should include a schedule for the planned destruction activities within the contract. The information should be consistent with the information given under Section III and Annex 2 of the present Terms of Reference.
2. Progress report: the contractor shall submit a progress report after the destruction of at least 37 metric tons of unwanted ODS, no later than 7 months after signature of contract. The report has to contain the data of the destroyed ODS as set out under the reporting criteria to the National Ozone Unit.
3. Draft final report: the contractor shall submit a draft final report after the complete destruction of the 74.1 metric tons of unwanted ODS. The report has to contain the data of the destroyed unwanted ODS as set out under the reporting criteria to the National Ozone Unit.
4. Final report: the contractor shall submit a final report at the end of the contract and should incorporate comment from UNIDO.

V. RECOMMENDED TABLES OF SCOPE OF SERVICES

UNIDO RFP reference No.

Scope of services

Technical table

UNIDO REQUIREMENTS		TO BE COMPLETED BY THE INVITEE	
Item	Name and required parameters	Compliance*)	Remarks**)
		yes/no	
1	General data from the company		
2	Detailed description of the destruction facility and certification		
3	Emission values of the destruction technology		
4	Additional information		
5	Provide a Commitment Letter		

*) compliance must be confirmed in detail in the by the contractor's offer and technical documentation and will be verified by UNIDO during technical evaluation;

**)if not compliant with UNIDO's required parameters, the invitee must indicate his parameters in this column

Commercial table

UNIDO REQUIREMENTS			TO BE COMPLETED BY THE INVITEE	
Item	Name and required parameters	Quantity	unit price	total item price
			currency	currency
1	Transportation costs as per Annex 1			
2	Cost for destruction per kg including storage and handling			
3	Cost of reporting			
4	Cost of registration of destruction activities under a voluntary carbon market scheme, if applicable			
	Total price:			

VI. EVALUATION CRITERIA

The company has to provide

1. General Data from the company
2. Detailed description of the destruction facility and certification
3. Emission values of the destruction technology
4. Commitment letter
5. Transportation costs
6. Cost for destruction per kg including storage and handling
7. Cost of registration of destruction activities under a voluntary carbon market scheme, if applicable

blank
page

**FINANCING OPTIONS TO ADDRESS CLIMATE CO-BENEFITS FOR HCFC PHASE-OUT
IN LVCS WITH SERVICING SECTOR ONLY**

Submitted to the 73rd Meeting of the Multilateral Fund
for the Implementation of the Montreal Protocol

by

United Nations Environment Programme (UNEP)

17 September 2014

ACKNOWLEDGEMENTS

This document was produced by UNEP Division of Technology, Industry and Economics (UNEP DTIE) OzonAction Programme as part of UNEP's work programme under the Multilateral Fund for the Implementation of the Montreal Protocol.

Researched and written by:

- Ms. Jane Barton, Patterson Consulting, Ottawa, Canada

Quality reviewed by:

- Ms. Donnalyn Charles, National Ozone Officer, Sustainable Development & Environment Officer, Ministry of Sustainable Development, Energy, Science and Technology Saint Lucia
- Mr. Steve Gorman, former Head of World Bank Montreal Protocol Unit

Feedback and suggestions provided by:

- National Ozone Officers and other experts who participated in the associated resource mobilisation workshops organized by UNEP.

The UNEP project team:

- Dr. Shamila Nair-Bedouelle, Head, UNEP DTIE OzonAction Branch
- Mr. James S. Curlin, Network and Policy Manager, OzonAction Branch
- Ms. Josephine Chona, Network Assistant, OzonAction Branch

Layout and design by:

- Aurélie Ek, Consultant

UNEP would like to thank all of the above persons for their contributions to this document.

Contents

- ACKNOWLEDGEMENTS2
- EXECUTIVE SUMMARY4
- SETTING THE SCENE6
- INTRODUCTION7
- 1. PHASE-OUT SCHEDULE FOR HCFCs9
- 2. DESCRIPTION OF LVCs WITH REFRIGERATION SERVICING SECTOR ONLY9
- 3. PROGRESS SO FAR ON HCFC PHASE-OUT IN LVCs WITH SERVICING ONLY AND WHAT THAT MEANS IN TERMS OF CLIMATE14
- 4. OVERVIEW OF ALTERNATIVES FOR HCFC IN REFRIGERATION AND AIR CONDITIONING17
- 5. FINANCING OPTIONS AVAILABLE TO LVCs SEEKING SUPPORT FOR CLIMATE BENEFITS21
- 6. GUIDE FOR OZONE OFFICERS.....35
- Annex 1: Overview of UNEP’s resource mobilization project.....45
- Annex 2: Summary of the regional resource mobilization workshops.....48
- Annex 3: Useful contacts and background information51
- Annex 4: Multilateral Fund eligible incremental costs of HCFC phase-out projects54

EXECUTIVE SUMMARY

This document provides guidance for Ozone Officers in low volume HCFC-consuming countries (LVCs) to help them understand how to seek financing outside of the Montreal Protocol's Multilateral Fund to achieve the climate co-benefits indicated in their national HCFC Phase-out Management Plans (HPMPs). LVCs have certain characteristics that are unique to their circumstances that can make accessing additional this financial support for HCFC phase-out projects particularly challenging, however the experience of some developing countries and the resource mobilisation projects of the Multilateral Fund's Implementing Agencies demonstrate that is possible. The vast majority of the HCFCs consumed in LVCs still remains to be phased out through Multilateral Fund projects, and since HCFCs both deplete the ozone layer and are greenhouse gases, LVCs have a clear opportunity to develop phase-out projects that meet both ozone and climate protection goals. Significant cost savings for equipment owners and governments can result when HCFC phase-out projects are designed to provide climate benefits. In order to develop such funding proposals, it is important for HCFC-related activities to be expressed in terms understandable by organisations that are used to climate change concepts and terminology, i.e. describing HCFCs as greenhouse gases using carbon dioxide equivalent (CO₂-eq) emissions. When developing a resource mobilization plan, Ozone Officers should identify the potential climate benefits in the servicing sector and understand who could benefit, i.e. the consumer, the equipment owner, the government and/or the environment. Climate co-benefits are frequently driven by increased energy efficiency in equipment using alternatives for HCFCs. There is a range of potential sources of financial support for climate co-benefits projects that an Ozone Officer should consider, including mainstreaming through Official Development Assistance, global level financial institutions with climate programmes, regional financial institutions that support climate benefits, government support for climate benefits as bilateral donors, and private sector support. A step-by-step guide for an Ozone Officer includes understand the refrigeration servicing sector, potential climate co-benefits and possible barriers; persuading management to seek climate co-financing for the HCFC phase-out; meeting with bilateral donors, international organizations and regional organisations that work in your country, making a compelling proposal, and preparing for discussions with potential donors.

LIST OF ACRONYMS

ACSP	African Carbon Support Programme
ADB	Asian Development Bank
AfDB	African Development Bank
CAS	Country Assistance Strategy
CDB	Caribbean Development Bank
CDM	Clean Development Mechanism
CER	Certified emission reduction
CFC	Chlorofluorocarbon
CFU	Carbon Finance Unit
CIF	Climate Investment Funds
CO ₂ -eq	Carbon dioxide equivalent emissions
EBRD	European Bank for Reconstruction and Development
ECA	Europe and Central Asia
EER	Energy efficiency rating
GEF	Global Environment Facility
GHG	Greenhouse gas
GWP	Global warming potential
HC	Hydrocarbon
HCFC	Hydrochlorofluorocarbon
HFC	Hydrofluorocarbon
HFO	Hydrofluoroolefin
HPMP	HCFC Phase-out Management Plan
HVAC&R	Heating, ventilation, air conditioning, and refrigeration
IADB	Inter-American Development Bank
IDA	International Development Association
IDBI	Industrial Development Bank of India
IEA	International Energy Agency
IFC	International Finance Corporation
IPCC	Intergovernmental Panel on Climate Change
LVC	Low volume HCFC consuming country
MDG	UN Millennium Development Goal
MT	Metric tonnes
NOU	National Ozone Unit
ODA	Official Development Assistance
ODP	Ozone Depleting Potential
ODS	Ozone depleting substance
OECD	Organisation for Economic Co-operation and Development
PRSP	Poverty Reduction Strategy Paper
RAC	Refrigeration and air conditioning
SE4ALL	Sustainable Energy for All Initiative
SEFA	Sustainable Energy Fund for Africa
SIDS	Small Island Developing States
TEAP	Technology and Economic Assessment Panel
UNDAF	UN Development Assistance Framework
UNDP	United Nations Development Programme
UNEP	United Nations Environment Programme
UNFCCC	UN Framework Convention on Climate Change
UNIDO	United Nations Industrial Development Organisation
VLVC	Very low volume HCFC consuming country

FINANCING OPTIONS TO ADDRESS CLIMATE CO-BENEFITS FOR HCFC PHASE-OUT IN LVCs WITH SERVICING SECTOR ONLY

SETTING THE SCENE

The UNEP report, *HFCs: A Critical Link in Protecting Climate and the Ozone Layer*,¹ set the scene with respect to the rapid growth of hydrofluorocarbons (HFCs) as the main replacements for hydrochlorofluorocarbons (HCFCs) under the Montreal Protocol on Substances that Deplete the Ozone Layer. It states that the ozone-depleting substances (ODS) being phased out under the Montreal Protocol, such as chlorofluorocarbons (CFCs) and HCFCs, are not only ozone-depleting but are also potent global warming gases. While the HFC replacement chemicals used in products such as refrigerators and air conditioners and do not deplete stratospheric ozone, many of them are also extremely powerful global warming gases that will have an adverse impact on the climate if their use as alternatives to HCFCs remains significant. Alternatives for HCFCs in refrigeration and air conditioning (RAC) applications that have less impact or no impact at all on the climate are being developed and used throughout the world as Parties to the Montreal Protocol implement their HCFC Phase-out Management Plans (HPMPs).

In developing countries with low and very low HCFC consumption, the challenges faced by Ozone Officers in meeting the HCFC phase-out targets may be more easily met if the opportunities available through financial support for projects that benefit the climate are understood and acted on. This document aims to explain what climate-related resource mobilization means and how it can help an Ozone Officer in a low-volume consuming country (LVC) or very low volume consuming country (VLVC)² meet the HCFC phase-out targets with financial assistance from both the Multilateral Fund for the Implementation of the Montreal Protocol and other financial institutions and mechanisms. Ozone protection projects can be linked with activities to enhance energy efficiency and reduction of greenhouse gas (GHG) emissions, thereby achieving a dual benefit of ozone protection and climate change mitigation. The document provides guidance on how a LVC can seek financial support to both phase out HCFCs in the refrigeration servicing sector — which includes both the refrigeration and air conditioning sub-sectors — through projects result in reduced energy consumption and meet a country's climate, environmental and health-related goals and objectives.

¹ UNEP, *HFCs: A Critical Link in Protecting Climate and the Ozone Layer A UNEP Synthesis Report* (November 2011), http://www.unep.org/dewa/portals/67/pdf/HFC_report.pdf

² Although there are sometimes considerable differences between low-volume and very-low volume consuming countries, for the purposes of this document the term LVC will be used henceforth as a generic term for both types of countries.

INTRODUCTION

During its 60th meeting, the Executive Committee of the Multilateral Fund agreed under Decision 60/44 that for HCFC phase-out projects to achieve the 2013 and 2015 HCFC phase-out compliance targets, it would provide additional funding of up to 25% above the cost effectiveness threshold for projects, when needed for the introduction of low global warming potential (GWP) alternatives. This provision thus encourages Article 5 countries to use replacements for HCFCs in their RAC investment projects that have less impact or no impact on climate – thereby achieving climate co-benefits.

Given that this additional funding of up to 25% related to climate benefits is not available to Parties with no HCFC manufacturing sector, the Parties that are LVCs need information and guidance on how to access additional funding and support for their HCFC phase-out. In recognition of this need, the Executive Committee, through Decision 63/22 (a), approved separate resource mobilization projects for each of the four implementing agencies: UNDP, UNEP, UNIDO and the World Bank. The project approved for UNEP, entitled “Resource mobilization to address climate co-benefits for HCFCs phase-out in LVCs with servicing sector only,” includes two elements: a paper on financing options (i.e. this document) and four regional workshops on co-financing.³

In preparation for the UNEP resource mobilization project, the final reports of the resource mobilization projects of UNDP, UNIDO and the World Bank proved to be useful. In addition, UNEP sought and received advice from the other Implementing Agencies in relation to their experiences working with National Ozone Units (NOUs) in LVCs who were seeking opportunities for resource mobilization. The regional workshops on co-financing also provided an opportunity for participants in LVCs to voice their needs in relation to resource mobilization and to provide their inputs to this document.⁴

This document is designed as guidance for Ozone Officers in LVCs to help them understand how to approach financing options to achieve climate co-benefits of the HCFC phase out. Although this document is specifically targeted to assist LVCs that only consume HCFCs for servicing RAC equipment, the document should be useful to all LVCs. It is intended to provide practical steps to guide Ozone Officers on how to identify support for the climate co-benefits of their HPMPs. It takes a step back and describes LVCs and the challenges and opportunities Ozone Officers in LVCs may face in identifying and accessing support to address climate co-benefits. The paper then outlines what climate benefits are possible in refrigeration servicing. It introduces the concept of co-financing and the various institutions that can provide support to LVCs as they phase out the HCFCs. Finally, it demonstrates how to prepare for discussions on co-financing with potential donors to address climate co-benefits during the HCFC phase-out.

The paper is divided into the following six sections:

³ For background about UNEP’s resource mobilization project, see Annex 1.

⁴ See Annex 2.

1. Phase-out schedule for HCFCs. The HCFC phase-out schedule for developing countries is outlined.

2. Description of LVCs with refrigeration servicing sector only. Countries with low or very low consumption of HCFCs are LVCs are the focus of the paper, in particular with and those with RAC servicing sector only. They are listed and described along with their unique challenges in relation to accessing financial support to implement their HPMPs.

3. Progress so far on HCFC Phase-out in LVCs with servicing only and what that means in terms of climate. This section reviews the data available on HCFC phase-out in LVCs with a RAC servicing sector only and sets out how much more must be achieved. It also discusses how to express HCFCs as greenhouse gases to set the stage for seeking climate benefits in HPMPs.

4. An overview of alternatives for HCFCs in refrigeration and air conditioning. The substitutes for HCFCs in the RAC sector are briefly introduced in this section along with a review of how to achieve climate benefits in the HCFC phase-out as it relates to the servicing sector. This section also makes the case for seeking financing to support climate benefits when implementing the HPMPs.

5. Financing options available to LVCs seeking support for climate benefits. This section introduces climate financing institutions that are options for LVCs, seeking support outside of the Multilateral Fund for climate co-benefits. It describes the kinds of support provided by the various financing institutions specific to an LVC.

6. Guide to Ozone Officers for accessing co-financing. This part of the financing options paper is intended to be used as a step-by-step guide for an Ozone Officer on how to move from understanding the opportunities that climate co-benefits can offer through to putting resource mobilization into practice.

1. PHASE-OUT SCHEDULE FOR HCFCs

In September 2007, the Parties to the Montreal Protocol agreed to accelerate the phase-out schedule for HCFCs through Decision XIX/6. The schedule for developing countries operating under Article 5 of the Protocol (Article 5 countries⁵) is presented in Table 1.

Table 1: HCFC Phase-out Schedule for Article 5 Parties

Schedule	Year
Baseline	Average of 2009 and 2010
Freeze	2013
90% (reduction of 10%)	2015
65% (reduction of 35%)	2020
32.5% (reduction of 67.5%)	2025
Annual average of 2.5%	2030 to 2040
0% (reduction of 100 %)	2040

Decision XIX/6 also:

- Directed the Executive Committee, in providing technical and financial assistance, to pay particular attention to Article 5 Parties with low volume and very low volume consumption of HCFCs;
- Encouraged Parties to promote the selection of alternatives to HCFCs that minimize environmental impacts, in particular impacts on climate, as well as meeting other health, safety and economic considerations⁶; and
- Agreed that the Executive Committee, when developing and applying funding criteria for projects and programmes, would give priority to cost-effective projects and programmes which focus on, *inter alia* substitutes and alternatives that minimize other impacts on the environment, including on the climate, taking into account global warming potential (GWP), energy use and other relevant factors.

2. DESCRIPTION OF LVCs WITH REFRIGERATION SERVICING SECTOR ONLY

Countries with low or very low consumption of HCFCs are LVCs including those with refrigeration servicing only are the main focus of this financing options paper. The characteristic of LVCs are described in this section, along with their unique challenges with respect to accessing financial support to implement their HPMPs.

⁵ Any Party to the Montreal Protocol which is a developing country and whose annual level of consumption of chlorofluorocarbons (CFCs) and halons is less than 0.3 kilograms per capita.

⁶ See Section 4.

During the current HCFC phase-out stage, for the purpose of Multilateral Fund projects, developing countries are classified according to their annual levels of HCFC consumption. Executive Committee decision 60/44 (xiii) defines an Article 5 country as a LVC if it has a total HCFC consumption of up to 360 metric tonnes (MT) or 19.8 Ozone Depleting Potential (ODP) tonnes in the servicing sector. The HCFC baseline established under the HPMP is used to determine whether the country meets the 360 MT threshold. If a country has HCFC consumption in the servicing sector and in manufacturing, and the total consumption is still less than 360 MT, then it is still considered an LVC.

All countries consume HCFCs in the RAC sector for servicing existing equipment. The focus of this paper is the LVCs that consume HCFCs only for servicing in the RAC sector – and do not manufacture products containing HCFCs or have a foam manufacturing component. The term “refrigeration and air conditioning” includes domestic, commercial and industrial refrigeration and domestic, commercial and mobile air conditioning.

There are 59 LVCs with servicing only, as follows:

Albania
Angola
Bahamas
Barbados
Bhutan
Brunei Darussalam
Burundi
Cambodia
Cape Verde
Central African Republic
Chad
Comoros
Congo
Cook Islands
Djibouti
Dominica
Equatorial Guinea
Eritrea
Ethiopia
Fiji

Gambia
Georgia
Grenada
Guinea-Bissau
Guyana
Haiti
Kiribati
Lesotho
Liberia
Malawi
Mali
Marshall Islands
Micronesia, Federated States of
Moldova, Rep
Mongolia
Montenegro
Mozambique
Nauru
Nepal
Niue

Palau
Papua New Guinea
Saint Kitts and Nevis
Saint Lucia
Saint Vincent and the Grenadines
Samoa
Sao Tome and Principe
Serbia
Sierra Leone
Solomon Islands
South Sudan
Suriname
Tanzania, Republic of
Timor Leste
Tonga
Turkmenistan
Tuvalu
Vanuatu
Zambia

In line with the Multilateral Fund document *Minimizing Adverse Climate Impact of HCFC Phase-out in the Refrigeration Servicing Sector*⁷ the term “refrigeration servicing sector” principally describes only the service of existing refrigeration equipment. In reality, technicians’ expertise is also

⁷ Document UNEP/OzL.Pro/ExCom/72/42, <http://www.multilateralfund.org/72/English/1/7242.pdf>. This document provides useful information and considerations about the refrigeration servicing sector that is relevant for current and future HPMPs. UNEP recommends that all Ozone Officers read this document.

frequently used for the additional task of assembly, installation, initial charging and commissioning of new refrigeration equipment, and in particular when such equipment is custom-made for specific installations (e.g. supermarkets, refrigerated transportation, etc). The initial refrigerant charge in new systems has an estimated share between 20 to 60 per cent of HCFC servicing-sector consumption for most countries.

There is almost no data regarding the distribution of service-sector consumption between actual service and assembly/ installation/ initial charging/ commissioning. In fact, HCFC-22 uses related to the installation and initial charge of refrigeration equipment is absent from almost all HPMPs. The main difference between the two groups of tasks is that in many cases in which the service sector is performing assembly, installation, initial charging and commissioning, the choice of technology is not limited by an already existing system. In comparison, the actual servicing of refrigeration equipment provides only a limited possibility of changing the technology selected when the equipment was procured, as each refrigeration system has been specifically designed for one refrigerant. Despite this, for the purpose of this document on financing options, “servicing” includes retrofitting/conversions.⁸

All Article 5 countries face challenges in phasing out HCFCs – challenges that differ from those faced in the CFC phase-out. Actual consumption of HCFCs in MT has exceeded the peak of CFC consumption by 200%. In terms of impact, however, the ODP of HCFCs is only 10-20% that of the ODP of CFC-11/12. This implies that more phase-out interventions and investments will be required to accomplish the same level of ODP reductions achieved for CFCs. Further, because most HCFC consumption is in the RAC sector, the fleet of HCFC-dependent equipment world-wide will continue to be dependent on HCFCs for servicing, despite that the upcoming control measures under the Montreal Protocol will limit HCFC supply. An added challenge is that many HCFC-using enterprises and households own equipment that is far from the end of its product life as a result of recent conversion from CFC use.⁹

Other challenges to transforming HCFC consuming sectors are the low price of HCFCs as compared to alternatives and the degree of availability of affordable alternative technologies for developing countries. The price of HCFC-22 in particular has remained low and is expected to remain so in the foreseeable future.¹⁰

⁸ Executive Committee Decision 72/17 states that “anyone engaging in retrofitting HCFC-based refrigeration and air-conditioning equipment to flammable or toxic refrigerants and associated servicing, does so on the understanding that they assume all associated responsibilities and risks.” New equipment that is specifically designed to use flammable refrigerants can be appropriate options to replace HCFCs in developing countries, and should be considered. However, due to safety concerns, UNEP’s Compliance Assistance Programme cautions on the conversions (i.e. retrofits or drop-ins) of existing refrigeration and air conditioning equipment - or any existing equipment with large charge size - to use flammable refrigerants which include, but are not limited to, hydrocarbons.

⁹ Leveraging Support for HCFC Phase-out: Opportunities and Modalities for Pursuing Linkages with the Climate Change Agenda. Montreal Protocol Operations, Environment Department, The World Bank.

www.worldbank.org/montrealprotocol www.carbonfinance.org

¹⁰ Leveraging Support for HCFC Phase-out: Opportunities and Modalities for Pursuing Linkages with the Climate Change Agenda. Montreal Protocol Operations, Environment Department, The World Bank.

www.worldbank.org/montrealprotocol www.carbonfinance.org

Unlike other Article 5 countries, LVCs have certain characteristics that are unique to their circumstances that can make accessing additional financial support for HCFC phase-out projects particularly challenging. A few of these circumstances are described below:

- It is difficult to design “one size fits all” solutions. As a group, LVCs vary widely with respect to geography, capacity to diagnose problems and design appropriate solutions, and economic, social, and environmental conditions.

Possible solution: From the initial project concept through the proposal drafting stages, the Ozone Office should tailor the proposal to specific, articulated national need and circumstances, involving a wide consultative process with national stakeholders to ensure a proper design.

- Many LVCs do not have national or regional facilities for disposal/destruction of waste ODS. Waste ODS must be transported resulting in high costs, an important factor in project implementation.

Possible solution: If the resource mobilisation project includes ODS disposal, take such costs into consideration and determine if there are less expensive or alternative ways to address the waste issue. Alternatively, consider approaching the waste issue on a regional basis or finding private sector companies that are willing to take the waste at no cost (e.g. to reclaim and re-sell).

- LVCs by definition consume small amounts of ODS so there will be few, if any, “economies of scale” available to reduce the cost of implementation actions. The costs to reduce HCFCs in an LVC, on a per tonne basis, will be intrinsically more expensive than in a country that has higher consumption. From a climate change point of view, it also means that LVCs face a mitigation quandary due to low GHG emissions baselines that limit access to financing that is available from financial institutions devoted to supporting projects related to climate change.

Possible solution: Consider joint actions with other countries in the region to achieve a sufficiently large level of consumption (e.g. a regional project). Alternatively, by joining other larger initiatives already underway (e.g. energy efficiency programmes), the HCFC component could “tag along” with a larger project and thus avoid the need for an economy of scale related only to the HCFC component.

- LVCs rely heavily on costly petroleum-based fuels for power generation. Since refrigeration and air-conditioning alone accounts for 40%-60% of total electricity consumption in developing countries, the power requirements and cost of power for refrigeration and air conditioning in a LVC can be prohibitive for the consumer and equipment owner. With projected increasing global demand for refrigerators and air conditioners, governments in LVCs face power generation capacity issues along with the costs that developing more capacity brings.

Possible solution: Use this fact to your advantage when making the argument for a resource mobilisation proposal. By including energy efficiency components in the project proposal, the project outcome will reduce the need for power generation and fuel. Alternatively, consider adding components on renewable energy to the HCFC project (e.g. solar air conditioning).

- An LVC may have difficulty attracting financial support for its projects. It can be difficult for financial institutions to support projects in an LVC if the institution's administrative fees assessed as a percentage against a small project are insufficient to cover the actual costs of the administrative support.

Possible solution: This is a reality and must be taken into account during the design stage. Discuss with your Director ways in which the project could be combined with other projects to have sufficient project size that is sufficient to justify the administrative costs. Donors may also have special administrative provisions for smaller countries.

- Ozone Officers in LVCs may not have experience in resource mobilisation since it is not their traditional role. Typically there are limited human and institutional resources available in LVCs for activities such as investigation into options, donor consultations, preparation of proposals and establishment of national mechanisms (if needed) to receive funds.

Possible solution: Within your limits, test the waters by pursuing one of the climate co-benefits activities indicated in your country's HPMPs. This will build your capacity and provide you with a baseline about how much time and effort is really involved. Consider it a learning experience.

3. PROGRESS SO FAR ON HCFC PHASE-OUT IN LVCs WITH SERVICING ONLY AND WHAT THAT MEANS IN TERMS OF CLIMATE

This section reviews the available data on HCFC phase-out in LVCs with servicing only and sets out how much more must be achieved. It also discusses how to express HCFCs as greenhouse gases and makes the case for how seeking financing that has climate benefits when implementing the HPMP can open doors to financial support to supplement the Multilateral Fund.

According to Montreal Protocol Article 7 data, LVCs with servicing only consume four types of HCFCs for RAC servicing:

- HCFC-22 is used as a refrigerant in several applications such as unitary air conditioners, cold storage, retail food refrigeration equipment, chillers, and industrial process refrigeration.
- HCFC-123 is used in the RAC sector mainly in centrifugal chillers for industrial process refrigeration and commercial comfort air conditioning.
- HCFC-124 is minimally used as a refrigerant; its primary use as a refrigerant is in blends in industrial processes and transport refrigeration equipment. It is used as a component in mixtures in some CFC-12 drop-in replacements. It replaces CFC-114 in some heat pumps and special air conditioning equipment.
- HCFC-142b is used as a refrigerant only as a component of a few refrigerant blends. While HCFC-142b refrigerant blends are approved as acceptable substitutes for CFC refrigerants in some end-uses, their use is small and declining. R-409A (composed of HFC-125, HFC-134a and HFC-142a) is the most common refrigerant blend using HCFC-142b.

Table 2 indicates the current status of consumption in LVCs with servicing only for the major HCFCs, based on the most recent data reported by countries under Article 7 of the Montreal Protocol. The table also presents the quantity of HCFCs planned to be phased out by Multilateral Fund-supported projects that are currently being implemented, plus the remaining quantity of HCFCs still to be phased-out (i.e. the difference of the first two columns).

Table 2. HCFC consumption status in LVCs with servicing only

Substance	Consumption baseline (MT)	Quantity of HCFCs being phased out through approved projects (MT)	Quantity of HCFCs remaining to be phased out through approved projects (MT)
HCFC-22	209.36	82.23	127.13
HCFC-123	.02	0.00	.02
HCFC-124	.01	.01	.01
HCFC-142b	1.81	1.11	.70
Total	211.2	83.35	127.86

Source: Ozone Secretariat, Article 7 data

Based on these data, it is clear that 60% of the HCFC-22, which is the vast majority of the HCFCs in LVCs with servicing only, remains to be phased out through Multilateral Fund projects. Because

HCFCs both deplete the ozone layer and are greenhouse gases, LVCs with servicing only have a clear opportunity to develop phase-out projects for the remaining 60% of the HCFCs that meet both ozone and climate goals. As will be shown in Sections 4 and 5 of this paper, significant cost savings for equipment owners and governments result when HCFC phase-out projects are designed to provide climate benefits. The Montreal Protocol thus has a major opportunity to achieve even more significant climate co-benefits than it has already so far (see box 1).

Box 1: The climate benefits of the Montreal Protocol

The 1987 Montreal Protocol on Substances that Deplete the Ozone Layer called for the phase-out of the global production, consumption, and emissions of ODSs that are also potent greenhouse gases that contribute to climate change. The climate protection already achieved by the Montreal Protocol alone is far larger than the reduction target of the first commitment period of the Kyoto Protocol.

In order to develop projects with climate benefits, as a first step, it is important for HCFCs to be expressed in terms understandable by organisations that are used to climate change concepts and terminology, i.e. describing HCFCs as greenhouse gases using carbon dioxide equivalent (CO₂-eq) emissions. To translate HCFCs into a metric that will be understood in relation to climate change, the global warming potential or GWP (see box 2) of each specific HCFC is used to calculate the “Carbon Dioxide equivalent (CO₂-eq) emissions” of each HCFC.¹¹ Since some greenhouse gases are more potent and have a higher GWP than others, emissions of greenhouse gases are typically expressed as CO₂-eq emissions to allow a direct comparison of their impacts on climate.

Box 2: Global Warming Potential (GWP)

The GWP represents how long GHGs remain in the atmosphere and their relative effectiveness in absorbing outgoing thermal infrared radiation. It is a relative index that enables comparison of the climate effect of the emissions of various GHGs and other climate changing agents like ODS. Carbon dioxide is chosen as the reference gas and ODS that are greenhouse gases like HCFCs can be translated into carbon dioxide equivalent emissions (CO₂-eq). A GWP value calculated for a time horizon of 100 years is known as “100-year GWP.”

Carbon dioxide has a GWP of 1, whereas the HCFCs consumed in LVCs have significantly higher global warming potentials:

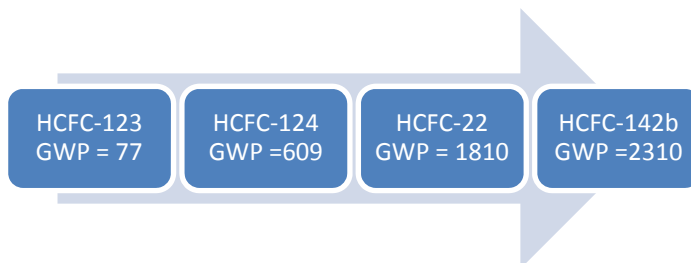

¹¹ Intergovernmental Panel on Climate Change (IPCC), Fourth Assessment Report (AR4), Working Group 1, Chapter 2, *Changes in Atmospheric Constituents and in Radiative Forcing*, Table TS.2. Lifetimes, radiative efficiencies and direct (except for CH₄) global warming potentials (GWP) relative to CO₂. {Table 2.14} http://www.ipcc.ch/publications_and_data/ar4/wg1/en/tssts-2-5.html

For reference, the GWP of HFC-134a, which is one of the main alternatives for HCFC-22 identified in the HPMPs of LVCs, is 1430.

To calculate the CO₂-eq for HCFCs, the metric tonnes of the different HCFCs are multiplied by their specific GWP.

$$\text{HCFC MT} \times \text{GWP} = \text{CO}_2\text{-eq}$$

Table 3 presents the total CO₂-eq emissions for HCFCs in the LVCs with servicing only in terms of the baseline, the quantity of HCFCs already being phased out through approved projects and the remaining quantity of HCFCs that can be incorporated into phase-out projects that can achieve climate benefits.

Table 3. CO₂-eq emissions of HCFCs in LVCs with servicing only, based on their GWPs¹²

Substance	Consumption baseline (MT)	Consumption baseline expressed in CO ₂ -eq emissions	HCFCs being phased out through approved projects expressed in CO ₂ -eq emissions	HCFCs remaining to be phased out through approved projects expressed in CO ₂ -eq emissions
HCFC-22	209.36	378,941.60	148,836.30	230,105.30
HCFC-123	.02	1.50	00	1.50
HCFC-124	.01	6.10	6.10	6.10
HCFC-142b	1.81	4,181.10	2,564.00	1,617.00
Total	211.20	383,130.30	151,406.40	231,729.90

The 59 LVCs with servicing only have a significant quantity CO₂-eq emissions of HCFCs remaining to be phased-out and from which climate benefits would be worth pursuing. To support Ozone Officers in their efforts to design projects that bring climate benefits and attract financial assistance for their projects, the next two sections present information and guidance on the current status of HCFC alternatives, potential climate benefits from the HCFC phase-out and sources of financial support outside of the Multilateral Fund.

¹² Most current Montreal Protocol Article 7 data and Intergovernmental Panel on Climate Change (IPCC), Fourth Assessment Report (AR4), Working Group 1, Chapter 2, *Changes in Atmospheric Constituents and in Radiative Forcing*, Table TS.2. Lifetimes, radiative efficiencies and direct (except for CH₄) global warming potentials (GWP) relative to CO₂. {Table 2.14} http://www.ipcc.ch/publications_and_data/ar4/wg1/en/tssts-2-5.html

4. OVERVIEW OF ALTERNATIVES FOR HCFC IN REFRIGERATION AND AIR CONDITIONING

The alternatives for HCFCs in the RAC sector are briefly introduced in this section along with a review of how to achieve climate benefits in the HCFC phase-out as it relates to the servicing sector, through the selection of appropriate alternatives. This section makes the case for seeking financing to support climate benefits when implementing the HPMP.

It is important that the HCFC phase-out under the Montreal Protocol does not add to the deterioration of the climate through the use of HFCs that are potent greenhouse gases. The May 2011 *Progress Report of the Technology and Economic Assessment Panel* stated that “the challenge is to phase out HCFCs while avoiding high-GWP HFCs and while achieving high energy efficiency using technology that is safe and environmentally acceptable.”¹³ The Executive Committee encourages Article 5 countries during the implementation of their HPMPs to consider measures to facilitate the introduction of energy efficient and climate friendly alternatives.¹⁴

According to *Minimizing Adverse Climate Impact of HCFC Phase-out in the Refrigeration Servicing Sector*, when it comes to HCFC phase-out in the refrigeration servicing sector, adverse impacts on the climate refers to an increase in emissions of GHGs (expressed in CO₂-eq. emissions) with respect to whatever is the current situation.

Emissions can change with respect to “direct” emissions from the refrigeration sector that occur when GHG refrigerants are released in substantial quantities during manufacturing, installation, servicing and decommissioning/replacement of refrigeration equipment. The emissions per system tend to increase with increasing refrigerant charge of the equipment and increasing repair of the refrigeration cycle. Many of the refrigerants that are GHGs have high global warming potential.

Emissions can also change with respect to “indirect” emissions from the refrigeration sector. Indirect emissions are those released by the power source when electricity is generated to run the RAC equipment. Indirect emissions can be very significant in terms of GHGs when the electric power used to power RAC equipment is generated by fossil fuel combustion (e.g. oil, diesel, coal), which is most often the case in LVCs (see box 3).

Box 3: Lesson learned

Savings related to electricity, whether at the individual consumer level or from avoided generation capacity, dominate. When comparing the direct climate benefit arising from reductions in emissions associated with the replacement of HCFCs (given the intrinsic global warming potential of the refrigerant) with the indirect benefit associated with energy savings from new equipment (from the lower electricity consumption), the value of the

¹³ *Progress Report of the Technology and Economic Assessment Panel, May 2011, Volume 1*

http://ozone.unep.org/Assessment_Panels/TEAP/Reports/TEAP_Reports/TEAP_Progress_Report_May_2011.pdf

¹⁴ Multilateral Fund Secretariat, *Minimizing Adverse Climate Impact of HCFC Phase-out in the Refrigeration Servicing Sector* (UNEP/OzL.Pro/ExCom/72/42), para 44(c)(ii).

indirect benefit is larger... from a country perspective, it is energy security benefits that drive policy making directed at the RAC sector, with climate mitigation and ODS phase-out as secondary objectives only.¹⁵

— World Bank resource mobilization project

In meeting the Montreal Protocol requirement to phase out HCFCs, HFCs, hydrofluoroolefins (HFOs) including HFO-1234yf, HFO-1234ze, -1233zd(E), blends containing HFOs and natural refrigerants are the major replacements in many RAC applications. As a general differentiation, “natural refrigerants” are substances that exist naturally in the environment, while “non-natural refrigerants” or “synthetic refrigerants” such as HFCs and HFOs are man-made chemicals, not naturally occurring in nature. The most commonly used natural refrigerants today are ammonia (NH₃, R717), carbon dioxide (CO₂, R744), and hydrocarbons (HCs), such as propane (R290), isobutane (R600a), and propylene, also known as propene (R1270). Water and air are also used, to a lesser extent, for example in adsorption chillers and deep-freezing applications.

The alternatives for HCFC refrigerants in the RAC sector differ in terms of their GWP, energy efficiency, toxicity, flammability and cost both as refrigerants and in terms of system or design change costs required to accommodate them in existing equipment. Discussions about the alternatives and comparisons between them are being updated constantly as industry and governments look for ways to best meet the HCFC phase-out challenge.

A number of websites maintain and provide up-to-date information on the technology options for alternative refrigerants in the refrigeration sector including the following:

- UNEP Ozone Secretariat Technology and Economic Assessment Panel (TEAP)
http://ozone.unep.org/Assessment_Panels/TEAP/Reports/TEAP_Reports
- Regional Networks of Ozone Officers
<http://www.unep.org/ozonaction/RegionalNetworks/tabid/6203/Default.aspx>
- OzonAction Contacts Partnerships and Information Resources
<http://www.unep.org/ozonaction/InformationResources/Contacts/tabid/6549/Default.aspx>
- Information Clearinghouse (including the OzoNews electronic news service)
<http://www.unep.org/ozonaction/Home/tabid/5467/Default.aspx>
- United States Environmental Protection Agency Greenchill partnership with food retailers to reduce refrigerant emissions and decrease their impact on the ozone layer and climate change. <http://www2.epa.gov/greenchill>
- Wikipedia lists all the refrigerants with all the technical data
http://en.wikipedia.org/wiki/List_of_refrigerants

To add to these useful information sources are studies such as the November 2013, UNIDO *Guide 2013: Natural Solutions for Developing Countries including UNIDO Atmosphere Summary Report*¹⁶

¹⁵ World Bank Final Report on Resource Mobilization for HCFC Phase-out and Climate Mitigation Co-Benefits, p. iii (UNEP/OzL.Pro/ExCom/71/6/Add.1).

¹⁶ United Nations Industrial Development Organization, SHECCO SPRL. *Guide 2013: Natural Solutions for Developing Countries including UNIDO Atmosphere Summary Report*. November 2013
http://www.unido.org/fileadmin/user_media_upgrade/What_we_do/Topics/Multilateral_environmental_agreements/GUIDE-UNIDO-natural-substances-2013-small.pdf

prepared to facilitate the exchange of knowledge to help drive the uptake of low-GWP technologies among businesses and policy makers in developing countries and economies in transition. The *Guide* focuses on the benefits of natural low-GWP substances in the RAC sectors that can achieve both direct emissions savings and energy efficiency in support of “leapfrogging” directly from HCFCs to low-GWP options.

In relation to the refrigeration servicing sector specifically and how the HCFC phase-out can be implemented with as little impact on climate as possible, the document *Minimizing Adverse Climate Impact of HCFC Phase-out in the Refrigeration Servicing Sector* provides a comprehensive set of strategies that include:

- (a) Influencing a shift in technology choice toward technologies with lower climate impact for new, factory-charged refrigeration systems;
- (b) Influencing a shift in technology choice toward lower climate impact technologies for new refrigeration systems where the servicing sector performs, in particular, initial charging and commissioning, but frequently also assembly and/or installation. This strategy must include awareness raising as well as training in use and servicing of new technologies, undertaken as part of service-related activities;
- (c) Reducing charge size, thus reducing the amounts of refrigerants emitted in particular for systems where the service sector performs assembly and/or installation;
- (d) Reducing refrigerant emissions during servicing;
- (e) Improving product quality, installation quality and service quality, thus reducing the frequency of occurrence of leaks, ruptures and repairs;
- (f) Improving energy efficiency of equipment through better maintenance (e.g. adjustment of controls and cleaning of systems components); and
- (g) Retrofitting refrigeration equipment to technologies with a lower GWP, when feasible, assuming the following preconditions are met: safe conversion is possible; the emissions of refrigerant during conversion, plus the future emissions of refrigerant with a lower GWP through the remaining lifetime, measured in CO₂ equivalent tonnes, are lower than those associated with continuing to operate the existing system without changes; indirect emission increases due to possible increases in energy consumption related to the retrofit are not overcompensating any direct emission savings; and there are sufficient incentives (regulatory and/or economic) to avoid reversing the retrofit back to HCFCs.

Table 4 translates these strategies into the potential climate benefits and who could benefit – the equipment owner, the government and/or the environment.

Table 4. Climate co-benefits from the servicing sector

Activity	Potential benefit	Beneficiary		
		Equipment owner	Government	Environment
Good refrigeration servicing practices	Reduced purchases of refrigerant and cost savings	✓	✓	✓
	Reduced or avoided direct GHG emissions		✓	✓

Activity	Potential benefit	Beneficiary		
		Equipment owner	Government	Environment
Replacement of high-GWP refrigerants with low- or zero-GWP refrigerants	Reduced GWP of refrigerants		✓	✓
Replacement of vapour-compression equipment with equipment based on different cycles (e.g. adsorption)	Reduced or avoided direct GHG emissions		✓	✓
	Reduction of energy consumption (cost savings)	✓	✓	✓
	Reduced need for additional electricity generation capacity (power plants) and/or fuel imports		✓	✓
Improved energy efficiency of replacement technology	Reduction of energy consumption (cost savings)	✓	✓	✓
	Reduced need for additional electricity generation capacity (power plants) and/or fuel imports		✓	✓
Building design that avoids/minimizes need for refrigeration	Reduction of energy consumption (cost savings)	✓	✓	✓
	Reduction or avoidance of direct GHG emissions			✓
Recovery and recycling of refrigerants	Reduced requirement for importing/purchasing new refrigerants	✓	✓	✓
Destruction or disposal of waste/contaminated ODS	Reduction or avoidance of direct GHG emissions			✓
Refrigerant conversion/retrofits	Reduction or avoidance of direct GHG emissions	✓	✓	✓
	Reduced need for additional electricity generation capacity (power plants) and/or fuel imports	✓	✓	✓

It is clear that the main benefits of the range of activities to phase out HCFCs within the refrigeration servicing sector are fewer GHG emissions and cost savings for the consumer or equipment owner and governments. These benefits are driven by increased energy efficiency in equipment using alternatives for HCFCs that are low in GWP or are neither GHGs nor ODS (see box 4).

Box 4: Lesson learned

A high and fluctuating cost of electricity is considered to be a strong economic driver for the replacement of some types of RAC equipment, e.g. chillers.¹⁷

— *Multilateral Fund chiller project desk study*

A 2007 study by the International Energy Agency (IEA) examined the potential for reducing energy use in the air conditioning sector in an importing country that had to overcome barriers from a

¹⁷ Multilateral Fund *Desk Study on the Evaluation of Chiller Projects* (UNEP/OzL.Pro/ExCom/68/10), para 11.

lack of standards enforcement or advanced technologies to market penetration of air conditioners with higher energy efficiency ratings (EER). Table 5 estimates the potential decrease in GHG emissions in two Article 5 countries that would result from improving the energy efficiency rating of air conditioners.¹⁸

Table 5. Potential GHG emission reductions from reducing energy use in air conditioners

Country	Baseline EER	Targeted EER	Units Sold/Year	CO ₂ Emission Reduction (MT)
Ghana	2.55	2.8	100,000	3 million
China	3.4	5.00	4-18 million	28-61 million

Added to the decrease in CO₂ emissions due to the increased EER in the air conditioners, would be a reduction in costs for the equipment owner in relation to power consumption and reduced costs for the government in terms of power generation including imports of fuel. Some LVCs have begun exploring opportunities along these lines. For example, the Cook Islands has a programme designed to reduce energy consumption and costs to governments and consumers by replacing refrigerators and freezers with energy efficient appliances (see box 5).

Box 5: Fridge and Freezer Replacement Program in Cook Islands to Reduce Energy Consumption

A program announced in May 2012 for the Cook Islands is intended to reduce energy consumption in the residential, commercial and public sectors through the implementation of energy efficiency measures, and to establish policy frameworks to help Cook Islands move away from fossil fuel dependency. The program will reduce electricity consumption in the Cook Islands by promoting high energy efficient fridge/freezers. The Fridge and Freezer Replacement Program will encourage households to replace old inefficient fridges and freezers of 5 years or older with high energy efficient equipment. Participating retailers in the Cook Islands are being subsidized to offer rebates between 125USD and 410USD to customers purchasing selected high efficient fridge/freezer models, in exchange for their old, working fridges and freezers of similar capacity. Estimates are that approximately 40% of household electricity costs in Cook Islands are for refrigeration and that energy efficient fridges and freezers will save the average household an estimated 165USD to 245USD per year on electricity bills which would be a reduction of electricity consumption of approximately 20-30% for each participating household. The fridge/freezer replacement program seeks to initially target 325 households in Cook Islands over a one year period. Significant cost savings in household electricity bills and increased awareness of energy appliance labeling and the benefits of using energy efficient appliances are also expected benefits of the program. The program is co-financed by the Asian Development Bank (ADB), the Government of Australia, the Global Environment Facility (GEF) and the Asian Clean Energy Fund under the Clean Energy Financing Partnership and includes the participation of the Government of the Cook Islands, and the white goods retailers -Motor Centre and the Cook Islands Trading Corporation Limited.

5. FINANCING OPTIONS AVAILABLE TO LVCs SEEKING SUPPORT FOR CLIMATE BENEFITS

The preceding sections of this document highlighted that LVCs with servicing only have unique characteristics that can make accessing financing for HPMPs challenging. They also explained how

¹⁸ *Leveraging Support for HCFC Phase-out: Opportunities and Modalities for Pursuing Linkages with the Climate Change Agenda*. Montreal Protocol Operations, Environment Department, The World Bank. www.worldbank.org/montrealprotocol www.carbonfinance.org

the potential climate benefits could be derived from phase-out projects for the refrigeration servicing sector. Finally, they made the case that there are real benefits in terms of both GHG emissions reductions and cost savings when projects for HCFC phase-out are designed to have both ozone and climate benefits.

During the four regional workshops on resource mobilization organized by UNEP in 2013-2014,¹⁹ Ozone Officers expressed that their traditional roles focus on implementing the Montreal Protocol and that they do not have experience with mobilizing resources or approaching donors to initiate discussions about possible co-financing. Accordingly, this section provides an introduction to financing institutions that support climate-related projects. It then describes the eligible activities the various financing institutions fund that could be relevant to an LVC with servicing only seeking support outside of the Multilateral Fund to support achievement of climate co-benefits. To supplement the information in this section, useful background contact lists and web sites are provided in Annex 2.

FINANCIAL SUPPORT FOR CLIMATE-RELATED PROJECTS

Following is a brief description of key sources of financial support for climate co-benefits that are relevant to the Montreal Protocol and may be available to an LVC.

1. Mainstreaming through Official Development Assistance

Every LVC is already receiving some level of Official Development Assistance (ODA)¹⁹ based on its priorities and plans for development and poverty reduction. “Official Development Assistance” is defined by the Organisation for Economic Co-operation and Development (OECD) as flows of official financing administered with the promotion of the economic development and welfare of developing countries as the main objective, and which are concessional in character with a grant element of at least 25 percent (using a fixed 10 percent rate of discount). By convention, ODA flows comprise contributions of donor government agencies, at all levels, to developing countries (“bilateral ODA”) and to multilateral institutions.

As a first step in achieving financial support outside of the Multilateral Fund, it is important that an LVC work to integrate the HPMPs including both ozone and climate benefits as one of the priorities for assistance from ODA. By integrating or “mainstreaming” ozone and climate goals into the planning process that underpins ODA, it is possible to gain financial support from bilateral and multilateral donors for climate-related projects such as those in an HPMP (see box 6).

Box 6: Lesson learned

Good strategic planning and inter-sectoral coordination at the country level are crucial to ensure that policies are aligned and possibilities to leverage financing are optimized. Parties should be encouraged to ensure that their second phase HCFC Phase-out Management Plans include a broad and strategic overview of on-going and planned investments for climate mitigation and energy efficiency so that the Montreal Protocol interventions can be mainstreamed within these larger on-going programs. The overall domestic climate change and energy

¹⁹ See Annex 2.

policy and regulatory environment, including Nationally Appropriate Mitigation Actions (NAMAs) where relevant, should be providing the framework for the mainstreaming of HCFC phase-out.²⁰

— World Bank resource mobilization project

The process used to develop the development planning documents that underpin ODA are important to understand in order to identify the potential entry points that would enable an LVC to integrate or “mainstream” the ozone and climate goals from its HPMPs. As a foundation for ODA, the developing country government creates a Poverty Reduction Strategy Paper (PRSP) or a Country Assistance Strategy (CAS) to define and communicate the country’s priorities. The PRSP or CAS is considered by most multilateral or bilateral donors as the avenue to identify opportunities for providing financial support to a developing country, since ODA is usually country-driven. Depending on the country, the PRSP or CAS assesses and diagnoses a country’s policies, institutions and capacity using as a basis, work by the country or development partners that include sector analyses and strategies such as impact assessments and evaluations from prior or ongoing operations. Priorities are then identified in consultation with all relevant stakeholders, including civil society and donors. The PRSP or CAS is subsequently laid out with attention placed on macroeconomic policies, governance, sector policies, and costing and budget for proposed programs, as well as a monitoring and evaluation component. The nature and level of stakeholder participation has a significant impact on proposed priority actions in a PRSP or CAS.

The development planning process in most (though not all) developing countries is typically on a 4-5-year cycle, with a mid-term review to allow for adjustments to changing circumstances. Development planning is an intensive cross-sectoral effort for any country, usually led by a central agency, such as the Ministry of Finance and/or Development Planning, a National Planning Commission, a Prime Minister or President’s Office, etc. The major development plan of the government is a key (but not exclusive) driver of national budgetary decisions and expenditures, and is the main basis for discussions with development partners (donor countries) regarding assistance for the development of the country.

Opportunities to integrate ozone and climate benefits of the HPMP into the PRSP or CAS development planning documents can be initiated at the following stages in the process:

1. During analytical and diagnostic work to increase awareness
2. Through discussions with relevant government ministries, in particular ministries of finance
3. Through the mobilization of environment and health constituencies, including civil society
4. When coordination, decision-making and monitoring are established for institutional and technical aspects of the development plan
5. Through overall coordination and partnerships at various levels.

2. Global Level Financial Institutions and Partnerships with Climate Programs

There are certain global level financial institutions that offer support for climate-related projects. These are introduced below.

²⁰ World Bank Final Report on Resource Mobilization for HCFC Phase-out and Climate Mitigation Co-Benefits, p. iv (UNEP/OzL.Pro/ExCom/71/6/Add.1).

The World Bank (www.worldbank.org). Financing climate change is an important part of the World Bank Group's business. This focus has resulted in financing flowing to support low-emissions and resilient development. For example, mitigation support for the world's poorest countries through the Bank's International Development Association (IDA)²¹ reached USD 2.3 billion during fiscal year 2013, while the International Finance Corporation's (IFC)²² mitigation financing increased 50 percent to USD 2.5 billion. The World Bank has demonstrated innovative ways to mobilize additional resources to finance climate action by working with partners. The most notable success has been the USD 7.3 billion Climate Investment Funds (CIFs),²³ which are playing a key role in meeting international objectives regarding climate change. The World Bank is trustee of 15 carbon finance initiatives. The Carbon Finance Unit (CFU)²⁴ supports more than 150 projects through purchase of about 220 million metric tonnes of CO₂ equivalent emissions.

The World Bank helps countries to assess and manage climate risks and provide analytical guidance. Portals such as the Climate Change Knowledge Portal²⁵ and the Climate Finance Options Platform²⁶ provide cutting edge information, analysis, and tools on climate change. Increasingly, the Bank is engaging in strategic partnerships to both deepen the climate change knowledge base for clients and to address critical issues such as low-GWP refrigerants.

Within the context of Climate Finance is the certified emission reduction (CER) which is a unit representing one tonne of carbon dioxide-equivalent (CO₂-e) sequestered or abated. CERs are issued to project participants in Clean Development Mechanism (CDM) projects pursuant to Article 12 of the Kyoto Protocol and the CDM modalities and procedures.²⁷ CERs have, in the past, been important sources of financial support for climate-related projects. In August 2008 prices for CERS were USD 20 per tonne but by October 2012, CER prices had fallen to €1.36 per tonne on the London ICE Futures Europe exchange. In October 2012 Thomson Reuters Point Carbon calculated that the oversupply of units from the CDM and Joint Implementation would be 1,400 million units for the period up to 2020.²⁸ It is unlikely, therefore, that CERs will prove to be a feasible source of financial support for an HPMP for the coming years.

Global Environment Facility (GEF) (<http://www.thegef.org/gef/>). The GEF has served as the largest provider of grants to address climate change for the past 20 years. Its goal is to transform the market development paths for eligible countries into trajectories with lower

²¹International Development Association (IDA) <http://www.worldbank.org/ida/>

²²International Finance Corporation (IFC)

http://www.ifc.org/wps/wcm/connect/corp_ext_content/ifc_external_corporate_site/home

²³ <http://treasury.worldbank.org/cmd/htm/index.html>

²⁴ <http://www.worldbank.org/en/topic/climatefinance>

²⁵ http://sdwebx.worldbank.org/climateportal/index.cfm?page=why_climate_change

²⁶ <http://www.climatefinanceoptions.org/cfo/index.php>

²⁷ Clean Development Mechanism: Rules, Practice and Procedures. <http://cdmrulebook.org/304>

²⁸ Wikipedia, the free encyclopedia. http://en.wikipedia.org/wiki/Certified_Emission_Reduction

GHG emissions in energy, industry, transport and land-use sectors. The way the GEF achieves its climate-related goals is by removing barriers to sustainable market development and through pilots and demonstration projects. Support is provided as grants and limited non-grant instruments. Over the 2010-2014 period, USD 350 million per year has been allocated to this area - USD 2.7 billion since the GEF's inception. The size of the GEF grants for projects range from 5 million USD to 50 million USD.²⁹ An example of a project supported by the GEF that has both ozone and climate benefits is provided in box 7.³⁰

Box 7: Swaziland SolarChill project

In support of technology transfer to increase energy independence, the GEF has approved USD 2.7 million for the further development of "SolarChill", combining the use of solar energy with "Greenfreeze" hydrocarbon refrigeration in Kenya, Swaziland and Colombia. The "Solar-Chill Development, Testing and Technology Transfer Outreach" project is intended to increase the market potential of SolarChill technology in vaccine and food refrigeration applications in areas without electricity. The technology integrates the use of solar energy with hydrocarbon refrigeration and eliminates the need for lead storage batteries by using solar direct drive compressors to create an ice bank, thus storing the energy of the sun in ice. The intent of the GEF funding is a large-scale demonstration of SolarChill technology, to give it higher global recognition, especially in developing countries. A second aim is to encourage companies, especially in Southern African and Latin American regions, to take up production of the technology.

The Climate and Clean Air Coalition (www.unep.org/ccac/). This broad coalition of State and non-State partners was launched by UNEP and six countries — Bangladesh, Canada, Ghana, Mexico, Sweden and the United States — in 2012. The CCAC aims to catalyze rapid reductions in short-lived climate pollutants to protect human health, agriculture and the environment. The CCAC's HFC Initiative works with governments and the private sector to address rapidly growing HFC emissions. The initiative aims to bring together a high-level global roundtable to establish private sector and government pledges to promote climate-friendly alternatives and technologies; minimize HFC leaks; and encourage recovery, recycling, reclamation, and destruction of HFCs. The CCAC has supported certain pilot projects in countries, including several LVCs, that can be considered as resource mobilization for the climate co-benefits of the HCFC phase out (see box). The initiative has so far worked with Bangladesh, Chile, Colombia, Ghana, Indonesia and Nigeria to conduct HFC inventories in their countries, and UNEP recently received approval to support. The initiative has also sponsored two major conferences on HFC alternatives and developed case studies for commercial refrigeration technologies (see box 8).

²⁹ The World Bank. *Beyond the Sum of Its Parts Combining Financial Instruments for Impact and Efficiency*. ISSUES BRIEF #3, June 2010. Table 1. http://www-wds.worldbank.org/external/default/WDSContentServer/WDSP/IB/2010/06/25/000334955_20100625030802/Rendared/PDF/553290BRI0Box349445B01PUBLIC1.pdf.

³⁰ United Nations Industrial Development Organization, SHECCO SPRL. *Guide 2013: Natural Solutions for Developing Countries including UNIDO Atmosphere Summary Report*. November 2013. Page 43 http://www.unido.org/fileadmin/user_media_upgrade/What_we_do/Topics/Multilateral_environmental_agreement_s/GUIDE-UNIDO-natural-substances-2013-small.pdf

Box 8: Lesson learned

The CCAC experience was successful with the approved feasibility study for Maldives, with an “out of the box” approach regarding technology choices, such as District Cooling. UNDP believes that once the study is finalized this demonstration project could be used by other countries, especially SIDS.³¹

— UNDP resource mobilization project

3. Regional Financial Institutions that support Climate Benefits

Financial institutions at the regional level that support climate-related goals are very important to LVCs with servicing only. As discussed in Section 3, the fact that individual LVCs have less HCFCs to phase-out and therefore less CO₂ equivalent emissions to avoid can make access to financial support difficult. An LVC by itself may, therefore, not be able to find support for its own ozone and climate-related projects. On the other hand, a regional approach for LVCs could attract more interest among financial institutions. There is, therefore, value in exploring a regional approach by collaborating with other LVCs to seek support from a financial institution that has a regional focus.

Regional-level financial institutions can also be a valuable source of advice and can bring together a number of public and private sources of finance for support in project development and implementation. An example of this is the project to promote energy efficiency in Cook Islands, Samoa, Tonga, Vanuatu and Papua New Guinea (see box 9).³²

Box 9: Promoting Energy Efficiency in the Pacific

The Cook Islands, Samoa, Tonga, Vanuatu and Papua New Guinea have developed an innovative project for the GEF to be co-financed by the Asian Development Bank (14%), Governments of Cook Islands, Samoa, Tonga, and Vanuatu (26%), Power Utilities & Private Sector (24%), Government of Australia (14%) and Government of Japan (22%). The proposed project will result in the reduction in electricity and fuel consumption due to higher energy efficiency. The electricity and fuel saved from the successful implementation of the project will lead to a reduction of carbon dioxide emissions, which is estimated at 42,851 tons of CO₂ annually and an emissions reduction impact of 642,765 tons CO₂ over a 15-year period. Such an innovative regional project should provide inspiration for other countries to consider similar approaches related to the climate benefits of the HCFC phase out.

Regional Development Banks through which LVCs could find support for mitigation projects with climate co-benefits as well as support regionally in coordinating donors and mobilizing co-financing.

- The Asian Development Bank (ADB)³³, based in Manila, is dedicated to reducing poverty in Asia and the Pacific through inclusive economic growth, environmentally sustainable growth and regional integration. Established in 1966, it is owned by 67 members – 48 from the region. In 2012, ADB assistance totaled USD 21.6 billion, including co-financing of USD 8.3 billion. The ADB is providing financial and other assistance to implement solutions, providing technical

³¹ UNDP Final Report on Resource Mobilisation for Climate Co-Benefits, p. 6 (UNEP/OzL.Pro/ExCom/71/6/Add.1).

³² Promoting Energy Efficiency in the Pacific Phase 2. <http://www.ee-pacific.net/>

³³ Asian Development Bank. Mainstreaming climate change in ADB operations—Climate change implementation plan for the Pacific. Mandaluyong City, Philippines. 2009. Page 10 <http://www.adb.org/publications/mainstreaming-climate-change-adb-operations-climate-change-implementation-plan-pacific>

assistance, grants, and loans, in combination with access to mitigation funds (e.g., the in-house Asia Pacific Carbon Fund and Future Carbon Fund) and adaptation funds (e.g., the Water Financing Partnership Facility, and Adaptation Fund). ADB is an implementing agency of the GEF. ADB plays an important role in the Pacific region in donor coordination and mobilization of co-financing.

- Inter-American Development Bank (IADB)³⁴ In IADB's International Climate Programs and Finance, the Bank has a capacity to facilitate access to international sources of climate finance. Key sources of finance include: funds under the UN Framework Convention on Climate Change (UNFCCC) such as the GEF (particularly its climate window); carbon finance including the Kyoto Protocol's CDM; the CIF and the Adaptation Fund.
- Caribbean Development Bank (CDB)³⁵ The CDB Strategic Plan 2010-2014 outlines the climate change focus for the bank. Since many of the LVCs in the Caribbean region are Small Island Developing States (SIDS) that are particularly vulnerable to the effects of climate change, the CDB views assistance to its member States as support "to develop and implement mitigation and adaptation measures as a pro-growth strategy for the longer term." The CDB also sees the value of mainstreaming climate risk management in CAS papers and sector policies and strategies and of developing internal capacity within CDB to take on board climate change risk management, prepare and use climate risks tools, and develop external partnerships and networks.
- African Development Bank (AfDB)³⁶ The AfDB plays a role in backing climate change mitigation initiatives with its own resources, including leveraging financing from other sources, to incite investor confidence and participation in this emerging area. AfDB is working alongside other development partners including other Multilateral Development Banks (MDBs), UN organizations and bilateral development agencies to implement interventions that help Africa adapt to a changing climate as well as mitigate its risks.

The AfDB has embarked on an ambitious program at powering a low-carbon pathway in Africa. Through the Energy, Environment and Climate Change Department, the Bank serves as a platform to deliver advisory services necessary to mobilize transformative environment and climate finance, including assisting countries with projects to access carbon markets. Funds channeled through financing windows such as the CIF, the GEF, a recently created Sustainable Energy Fund for Africa (SEFA), the first phase of African Carbon Support Programme (ACSP), and the new Africa Hub of the Sustainable Energy for All Initiative (SE4ALL) are directly invested to support the transport, communications, agriculture, water and energy sectors. The

³⁴ Inter-American Development Bank. IDB Integrated Strategy for Climate Change Adaptation and Mitigation, and Sustainable and Renewable Energy. March 18, 2011. <http://www.iadb.org/en/civil-society/public-consultations/climate-change-strategy/climate-change-strategy,6974.html>

³⁵ Caribbean Development Bank (CDB). Strategic Plan 2010 – 2014 (Approved at the Two Hundred and Forty-First Meeting of the Board of Directors Held in The Bahamas on May 17, 2010). http://www.caribank.org/uploads/2012/03/Strategic_Plan2010_to_2014.pdf.

³⁶ African Development Bank Group. <http://www.afdb.org/en/>

goal is to ensure that climate finance effectively reaches the continent and is tailored to Africa's needs.³⁷

- European Bank for Reconstruction and Development (EBRD)³⁸ The overall goal of the EBRD is to foster transition to market economies in countries from Central and Eastern Europe to Central Asia and the Southern and Eastern Mediterranean. Underlying the work of the Bank is its Environmental and Social Policy³⁹ in which the EBRD states its intention to “support climate change mitigation and adaptation, in particular by investing in energy efficiency and renewable energy projects and by supporting best practices in climate change adaptation.” In addition to support for projects, the EBRD also is developing financing instruments that could be of interest to an NOU seeking support for climate co-benefits.

4. Government Support for Climate Benefits as Bilateral Donors

Funding organizations from other governments also play an important role in financial support to LVCs. Bilateral projects that are organized under the auspices of the Multilateral Fund as part of a Party's contributions to Multilateral Fund funding are not described here, since that assistance is officially part of the ODA provided to developing countries. Rather, this sub-section describes government organizations that provide funding assistance for environmental protection measures on a bilateral or regional basis outside of the Multilateral Fund.⁴⁰

- Government funds for bilateral development and technical assistance. Many developed countries, and an increasing number of developing countries, such as China, offer bilateral financial and technical assistance to support goals such as economic development, health and environmental protection in LVCs and other developing countries. Some of these bilateral funding organizations allocate specific funds to environmental protection programmes under which projects relevant to the Montreal Protocol and climate benefits of the HCFC phase-out can qualify. In a number of cases, national funding agencies already support work related to ODS phase-out under the Multilateral Fund. For example, the governments of Japan and Australia are co-funding, with the national governments in the Cook Islands, Samoa, Tonga, and Vanuatu, the project to increase energy efficiency described in Box 3.

There is potential for a group of Montreal Protocol donor Parties to consider organizing coordinated or bilateral support for Montreal Protocol-related activities that are beyond the scope or remit of the Multilateral Fund, e.g. for the adoption of low-GWP alternatives to HCFCs. If

³⁷ AfDB Continues to Support Low-carbon Development Pathways for Africa. 12/07/2013.

<http://www.afdb.org/en/news-and-events/article/afdb-continues-to-support-low-carbon-development-pathways-for-africa-12109/>

³⁸ European Bank for Reconstruction and Development. <http://www.ebrd.com>

³⁹ European Bank for Reconstruction and Development.

<http://www.ebrd.com/pages/about/what/policies/environmental/review/review.shtml>

⁴⁰ Touchdown Consulting. Information Paper on Funding Sources for Measures to Protect the Global Environment. December 2012. Prepared for the European Commission. Ref. Ares(2013)1410965 - 27/05/2013. page 10-12.

http://ec.europa.eu/clima/policies/ozone/research/docs/funding_information_en.pdf

several such Parties were willing, there could be potential for formally or informally developing a strategic plan for such activities.

5. Private Sector Support

Industry can be an important player in providing financial support to projects in an LVC particularly where there is an opportunity to increase market share for products including continuing the provision of parts and labour. The private sector participates in every aspect of the RAC sector including the design of RAC equipment, development of HCFC alternatives and substitutes, helping to design minimum standards for safety, health and environment, and setting costs of refrigerants and equipment. If there is an opportunity for a private sector firm to profitably participate in an LVC's HCFC phase-out project, there is a potential for private sector financial support (see box 10).

Box 10: Lesson learned

Over 90 percent of climate change finance is sourced from private markets (venture capital, asset financing, etc.), however, public finance is critical to removing barriers to climate technologies and attracting direct investment.⁴¹

— UNDP resource mobilization project

The private sector actively participated in the regional workshops on resource mobilization organized by UNEP in Australia, Macedonia and Jamaica and in each case, their contributions were related to introducing or extending their equipment and refrigerant product lines into the countries in the region. For instance, a Canadian company, Sustainable Options Limited, presented its experience with retrofitting hydrocarbon refrigerants within the English-speaking Caribbean. In the Australia workshop, the Australian Institute of Refrigeration Air Conditioning and Heating presented "PRIME," which is an initiative developed by a coalition of stakeholders from within the Australian heating, ventilation, air conditioning, and refrigeration (HVAC&R) industry to help reduce the environmental impact of HVAC&R. According to the presentation, a key driver for PRIME was the fact that a 2012 report showed that Australian refrigeration and air conditioning was responsible for 11.7 per cent of total national CO₂-eq emissions, with more than 45 million individual pieces of equipment consuming about 22% of all electricity used nationally. Among the outcomes of PRIME will be changes within the sector that are low cost, low carbon and low environmental impact – all of which are important components for an HCFC phase-out project in an LVC.

WHAT CAN BE FUNDED

All government institutions that provide funding to developing countries have limitations with respect to what types of activities their financial support can be directed towards. While this is not the case for private sector assistance, any financing proposals to industry may need to demonstrate how the proposed activities could benefit business, at least in the long-term.

With respect to the HCFC phase-out, the Multilateral Fund supports Article 5 countries for both the preparation and implementation of their HPMPs including projects to phase-out HCFCs,

⁴¹ UNDP Final Report on Resource Mobilisation for Climate Co-Benefits, p. 5 (UNEP/OzL.Pro/ExCom/71/6/Add.1).

strengthening their regulatory frameworks, building capacity and increasing awareness, training custom officers and refrigeration servicing technicians, promoting alternatives, recovery and recycling of ODS, etc. The Executive Committee has produced guidelines for HPMPs for Article 5 countries that includes specific criteria for LVCs.⁴²

Co-funding with the Multilateral Fund is necessary to achieve climate benefits since these are not supported by the Multilateral Fund. For instance, energy efficiency gains or a country's energy independence may be outcomes of an HCFC phase-out project but support for these benefits must be found among the financial institutions that support climate benefits.

The World Bank's India Chiller Energy Efficiency Project is an interesting example of a project focused on energy efficiency and ODS phase-out. In that project, the Multilateral Fund, the GEF and Climate Finance under the World Bank have been combined with the Industrial Development Bank of India (IDBI) to support a common objective – sector-wide chiller replacement – for global environmental co-benefits.⁴³ The four financial institutions together are able to financially support the following activities:

- First component supported by the GEF: provision of incentives for investment in energy efficient chillers including providing the following incentives to remove market and techno-economic barriers: (a) chiller owners with either: (i) an upfront financial incentive to subsidize the cost of the replacement of centrifugal chillers before end of technical life; or (ii) an annual payment from a share of certified emission reductions to be generated from the actual energy savings achieved by the new chillers; (b) an incentive for chiller manufacturers, suppliers and energy service companies to actively participate in the project.
- Second component supported by the GEF and Carbon Finance: measurement, monitoring and verification of the power-output function of old chillers to be replaced, electrical consumption of new chillers, and cooling output in order to measure energy savings and emission reductions. The methodology for this measurement is from the CDM Executive Board.⁴⁴
- Third component supported by Multilateral Fund: technical assistance to support project readiness and sustainability through enhancing the awareness of relevant stakeholders in energy conservation measures, enhancing the understanding of the impact on the servicing sector of the decision to accelerate the phase-out of production of CFC, and strengthening the capacity of chiller owners and other stakeholders to monitor the performance of new chillers and to undertake refrigerant management.
- Fourth component: project management through a Project Management Unit established at IDBI which is a financial intermediary and responsible for implementing all activities under the project.

⁴² See Annex 3.

⁴³ India Chiller Project – MP Component. <http://www.worldbank.org/projects/P102790/india-chiller-energy-efficiency-project-mp-component?lang=en>. IDBI India Chiller Project. <http://www.climatefinanceoptions.org/cfo/node/65>

⁴⁴ Clean Development Mechanism (CDM) Executive Board. <https://cdm.unfccc.int/EB/index.html>

Figure 1 depicts how the three financial institutions – the Multilateral Fund, the GEF and Climate Finance have been designed to work together within the project to achieve the results. In this particular example, the Climate Finance support is in the form of payments for CO₂-equivalent CERs which are only provided after project implementation. This means that the Multilateral Fund and the GEF provide the crucial upfront financing to initiate the replacement program, put in place the operational framework and policies and deliver technical assistance.

Figure 1: Funding Sources and Objectives⁴⁵

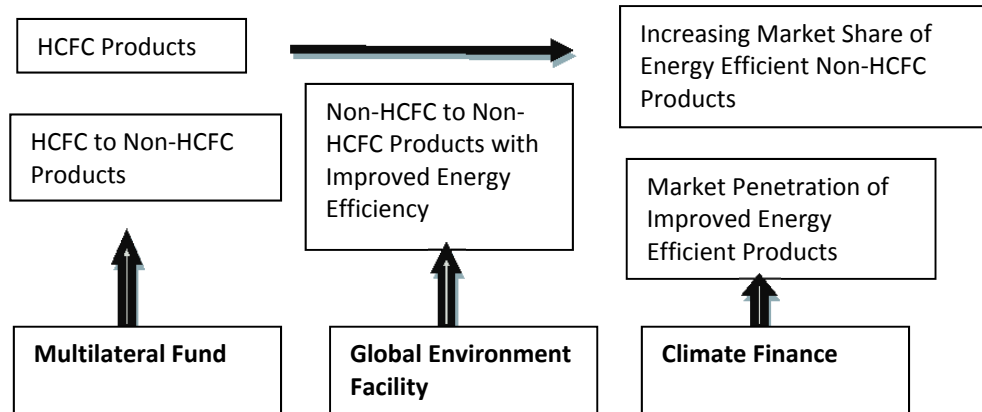

A good discussion of how various financing instruments support different aspects of a project can be found in *Beyond the Sum of Its Parts Combining Financial Instruments for Impact and Efficiency Beyond*⁴⁶. Table 6 is adapted from this publication suggests which financing instruments are able to finance the various components of a potential project.

⁴⁵ *Leveraging Support for HCFC Phase-out: Opportunities and Modalities for Pursuing Linkages with the Climate Change Agenda*. Montreal Protocol Operations, Environment Department, The World Bank. www.worldbank.org/montrealprotocol www.carbonfinance.org

⁴⁶ The World Bank. *Beyond the Sum of Its Parts Combining Financial Instruments for Impact and Efficiency*. ISSUES BRIEF #3, June 2010. http://www-wds.worldbank.org/external/default/WDSContentServer/WDSP/IB/2010/06/25/000334955_20100625030802/Rendecore/PDF/553290BRI0Box349445B01PUBLIC1.pdf.

Table 6: Climate change financing instruments to meet potential LVC needs in project design⁴⁷

Project financing needs	Available financing instruments
<i>Creation of enabling environment</i>	
To initiate and/or continue a relevant policy dialogue To make adjustments to policy or regulatory framework To provide project development funds To undertake technology piloting and demonstration To build capacity and train personnel To increase awareness	<ul style="list-style-type: none"> • GEF • Multilateral Fund • Trust funds such as Energy Sector Management Assistance program (ESMAP), Asia Sustainable and Alternative Energy Program (ASTAE), Public Private Infrastructure Advisory Facility (PPIAF) • Bilateral donor funds • IBRD resources also available
<i>Investment resources</i>	
<u>Private financing</u> : To invest in those projects that have a favorable risk-return profile for private sector financiers	<ul style="list-style-type: none"> • International private sector resources • National private sector resources • International Finance Corporation (IFC) resources
<u>Regional Development Banks or government financing</u> : To invest resources for short-to medium term investments with rate of return at or near market levels	<ul style="list-style-type: none"> • IBRD (Specific investment loan (SIL) or Development Policy Loan (DPL)) • Government resources • GEF (limited incremental investment resources)
<i>Risk mitigation</i>	
To cover risks or enhance credits associated with new technology, business models, resource certainty and country or currency risks	<ul style="list-style-type: none"> • Clean Technology Funds (partial risk guarantees) • GEF (limited resources or non-grant risk coverage) • Carbon finance (may help defray currency risks) • Multilateral Investment Guarantee Agency (MIGA)
<i>Revenue enhancement</i>	
To provide additional revenue stream to improve financial viability of investment	<ul style="list-style-type: none"> • Carbon finance funds • Output-based aid (Global Partnership for Output-Based Aid) • Non-World Bank carbon funds • Voluntary carbon markets

The *Desk Study on the Evaluation of Chiller Projects*⁴⁸ makes some further observations with respect to seeking financial support since it evaluated the funding and financial mechanisms used in the chiller projects. These observations, which are compiled in table 7, add some practical detail that could be useful for an Ozone Officer seeking co-funding to supplement support from the Multilateral Fund.

Table 7: Co-funding mechanisms involved in chiller projects

Co-funding Mechanisms	Time to Secure Co-financing	Availability of Funds	Observations
Appliance Owners or Users			Incentives are often required for purchase of

⁴⁷ The World Bank. *Beyond the Sum of Its Parts Combining Financial Instruments for Impact and Efficiency*. ISSUES BRIEF #3, June 2010. Adapted from Table 3. http://www-wds.worldbank.org/external/default/WDSContentServer/WDSP/IB/2010/06/25/000334955_20100625030802/Rendred/PDF/553290BRI0Box349445B01PUBLIC1.pdf.

⁴⁸ Executive Committee of the Multilateral Fund for the Implementation of the Montreal Protocol Sixty-eighth Meeting. *Desk Study on the Evaluation of Chiller Projects*. UNEP/OzL.Pro/ExCom/68/10. 12. Montreal, 3-7 December 2012. Paragraphs 33-42. <http://www.multilateralfund.org/68/English/1/6810.pdf>.

Co-funding Mechanisms	Time to Secure Co-financing	Availability of Funds	Observations
			replacement equipment.
Climate-oriented ODA	ODA funds are typically available within three months		
Bilateral ODA	Bilateral ODA funds typically are made available annually for Developing Country support which means that approved projects can be funded quickly.	Only a small number of countries are selected by donor countries to receive bilateral ODA. The reasons for choice of countries may be based on the current priorities of the donor country.	
GEF	GEF funding took up to two years after project approval.		
Private sector funds using innovative funding such as mandated contributions from national third party utility companies	National private sector funds could be secured on average in about 16 months		Innovative funding arrangements (ODA + private sector and/or carbon funding) possess a superior leveraging capacity, in particular where projects create tangible benefits for the co-financing entities.
Private sector funds using globally certified emission reduction credits in carbon markets (CDM)	Approval of a related globally applicable CDM methodology took about 30 months, but in exchange for the time lag, it created the potential for carbon market funding from verified energy savings in the future.		

Finally, further observations of practical interest came from the 2010 Joint Network Meeting for Ozone Officers of the Europe and Central Asia and South Asia Regional Networks in which lessons learned in the chiller projects were discussed.⁴⁹ Among the key messages given at the meeting that could be useful for Ozone Officers in LVCs who are interested in seeking financing outside of the Multilateral Fund for climate co-benefits includes:

- The Multilateral Fund and GEF have different project cycles (see box 11).
- Working with two GEF implementing agencies – the UNDP and the IADB, is difficult; and
- The performance guarantee fund and management structures are complex particularly considering the number of players involved and the detail in the management structure.

Box 11: Lesson learned on GEF

In average, GEF full size project development processes may take 3 to 8 years, depending on many factors, including but not limited to GEF availability of resource to respond to large pipeline of climate mitigation

⁴⁹UNDP. Joint Network Meeting for Ozone Officers of the Europe and Central Asia and South Africa networks Achievements and Lessons Learned Chillers Projects. Suely Carvalho, Chief Montreal Protocol & Chemicals Unit, UNDP. 26-30 April 2010, Istanbul

projects, including from previous replenishment cycles. In view of the long waiting list of projects, prioritization of pipeline entry by implementing agencies is an issue to overcome.⁵⁰

— *UNDP resource mobilization project*

⁵⁰ *UNDP Final Report on Resource Mobilisation for Climate Co-Benefits*, p. 5 (UNEP/OzL.Pro/ExCom/71/6/Add.1).

6. GUIDE FOR OZONE OFFICERS

This part of the financing options paper is intended to build on the information provided in Sections 1 through to 5, presenting a step-by-step guide for an Ozone Officer seeking to take advantage of climate co-benefits during the HCFC phase-out.

It should be noted that the suggestions in this guide are intended to supplement, not replace, the actions taken by an Ozone Officer in an LVC with servicing only when developing phase-out projects to replace, recycle or destroy HCFCs in accordance with the obligations under the Montreal Protocol.

STEP I – What you need to know: Understand your refrigeration servicing sector, potential climate co-benefits and possible barriers

It is important for the Ozone Officer to have the following kinds of information in order to prepare for discussions with national partners and potential donors for co-funding. While some of the information may already be in the HPMP, it may be necessary to collect other data in order to make the climate benefits case.

- Understanding the refrigeration and air conditioning servicing sector in your country
 - *Existing Refrigeration/Air Conditioning appliances* - What RAC equipment is used in the country? How many units are used in the commercial and domestic sectors? What are their capacities and efficiencies? What is the average remaining life of the equipment? What is the refrigerant leak rate? What is the current and forecast availability of different refrigerants? What is the estimated running time and average electricity consumption of the existing appliances? At what ambient temperature does the equipment operate?
 - *Socio-economic context* – What is the cost of electricity? Who owns the equipment? If the equipment is owned by commercial enterprises, what is the solvency of the companies? Are the owners willing to co-fund? What is the motivation for owners to replace their RAC equipment – is it the end of life of the appliance, the lack of ODS refrigerant supply, or some other reason?
 - *Regulatory context* – Are their existing national standards for RAC equipment? Does the country's import/export licensing system restrict imports of HCFC-based equipment imports? Are there any regulations or policies that promote the adoption of energy-efficient, low-GWP RAC technology?
 - *Replacement refrigeration and air conditioning* – What are the energy efficiency ratings for the equipment? What are the refrigerants and their GWPs? How much electricity does the equipment consume? What is the cost of the equipment? What is the cost and availability of refrigerants? Do servicing technicians have the skills and know-how required for servicing equipment using alternatives to HCFCs?
- Estimates of potential climate co-benefits
 - What are the estimated climate benefits if the existing equipment is replaced with new equipment with higher energy efficiency ratings that also use low- or zero-GWP

refrigerants? Such estimates could include, for example, avoided GHG emissions and cost savings for equipment owners and governments. Such estimates would depend on the specific RAC equipment and could be developed on the basis of the discussion in Sections 3 and 4 of how to calculate the CO₂-eq emissions and the potential climate benefits from the refrigeration servicing sector.

- Understanding possible barriers to taking action⁵¹

While developing a program with national partners and potential donors about co-financing opportunities, Ozone Officers should identify potential barriers and consider strategies to overcome them. The common types of barriers include:

- *Technical (refrigeration)* – Where there are specific technical issues that will not allow the use of a certain refrigerant, e.g. when the properties or characteristics of a refrigerant mean that it cannot be applied to a specific type of system or application.
- *Technical (safety)* – When there are specific safety issues that will not allow the use of a certain refrigerant, e.g. where the safety characteristics of a refrigerant are such that it cannot be applied to a particular application.
- *Supply and availability* – When a particular “part”, be it material, equipment, component or fluid or even a particular service (or activity), that is necessary for the operation (in-use or service/maintenance) of a system is not physically available or will not be or cannot be supplied to the user, thereby preventing the use of a specific refrigerant.
- *Commercial (investment, profit, financial incentives)* – Where an enterprise establishes that the cost of adopting a specific refrigerant will incur additional costs that will reduce profits beyond what is acceptable or where insufficient funding is available for investment or adequate financial incentives are unavailable.
- *Market* – Where an enterprise believes that there is no customer demand for a product that uses a particular refrigerant, or where the end-user or consumer would not accept a given refrigerant.
- *Information resources* – When insufficient information, know-how, guidance, or technical data either in the form of literature or training, is available to enterprises or technicians that need the know-how before they can embark on using a particular refrigerant.
- *Regulations and standards* – Where existing regulations prohibit the use of a particular refrigerant and where necessary standards do not exist within the country, or where the requirements of a regulation or standard are very restrictive thereby physically or financially (through stringent demands) prohibiting the use of the refrigerant.
- *Psychological and sociological aspects* – Where individuals, management of an enterprise or broader industry organisations hold a general resistance to change for the use of a particular refrigerant on the basis of rumour, influence of peer groups, or unwillingness to change to alternative technologies.

⁵¹ UNEP, *Barriers to the Use of Low-GWP Refrigerants in Developing Countries & Opportunities to Overcome These* (2010), pages 11-12, <http://www.unep.fr/ozonaction/information/mmcfiles/7476-e-Report-low-GWPbarriers.pdf>

STEP II – Who you need to convince: Persuade your management that your country should seek climate co-financing for the HCFC phase-out

Armed with an overview of the scope and nature of HCFCs in the country's refrigeration servicing sector, an estimate of the potential climate benefits both in terms of GHG emissions avoided and cost savings to the consumer, equipment owners and governments and a realistic view of any barriers to be overcome, an Ozone Officer can make a compelling case within the NOU and with key decision-makers that his/her government should seek climate co-financing for the HCFC phase-out.

STEP III - Who you need to meet: Bilateral donors, international organizations and regional organisations that work in your country

An important first step in accessing co-funding for climate co-benefits is for an Ozone Officer to become familiar with the key officials within the country and in other agencies in the government where actions of interest to the implementation of the HCFC phase-out may be underway. Examples include actions to implement standards, labeling and energy efficiency programs. Among the contacts Ozone Officers may want to engage are the following.

1. National focal points for the GEF and any other contacts or focal points in Climate type Funds described in Section 5.⁵² In an effort to promote "working with your partners on climate co-benefits", this should be the first order of business for an Ozone Officer in a NOU seeking financial support for climate co-benefits. Not only can there be complementary funding programs available but discussion and engagement may also reveal potential synergies or scope for cooperation between Multilateral Fund and GEF programs and projects.
2. Key individuals in central government agencies who are involved in the development of the country's CAS or the PRSP for the purposes of receiving ODA. As is described in Section 5, the major development plan of the government serves as the main basis for discussions with donor countries regarding assistance for the development of the country. Therefore donors could be looking for climate-related priorities in PRSPs or CASs to which their financial assistance can be targeted. The preparation of the PRSP or CAS is usually led by a central agency, such as the Ministry of Finance and/or Development Planning, a National Planning Commission, a Prime Minister or President's Office.

Experience from around the world indicates that extensive interagency and public consultation is critical to conclude a successful national development planning effort. The end result of the development planning process is the 5 year plan – the CAS or the PRSP depending on the development planning process. Through consultation with the central agencies that are developing the HPMP, it may be possible for an Ozone Officer to integrate or "mainstream" the HPMP and climate co-benefits into the country's sustainable development objectives and targets which could lead to support from IDA or IBRD and other global financial institutions.

⁵² See Annex 2.

Typically, development planning work starts at least 12-18 months in advance of the conclusion of the 5-year development plan that is in place. The following generic elements of development planning are typical:

- Diagnostics to determine the highest development priorities for the country and the key issues related to those priorities (e.g. poverty assessments, sector and sub-sector papers, assessments of technical and financial assistance needed to achieve the Millennium Development Goals (MDGs) over the long term, etc.);
 - Identifying policy options and choices to move towards national development objectives and targets (e.g. sectoral and cross-sectoral policy reforms and frameworks needed to accelerate growth with equity and promote long-term human development, etc.);
 - Identifying national capacity development needs to support implementation of priority actions to achieve national development objectives and targets (e.g. enable effective service delivery at the national and local levels, institutional changes, training needs, etc.);
 - Development of implementation plans and schedules for high priority objectives and targets; and
 - Investment planning and resource mobilization (costing infrastructure investments, equipment investments, micro-finance initiatives, assessing national budgetary implications, awareness raising and discussion with development partners, etc.).
3. Regional Development Banks operating in the region and in particular those that are implementing agencies for the GEF usually have contacts that can be engaged either by email or in person to discuss needs and ideas. They may be willing to develop projects including seeking public and private co-funding. For LVCs, a regional approach that is developed with several LVCs and implemented through a regional development bank such as the Asia Development Bank can be much more feasible than one operating individually as a country. An Ozone Officer should be able to contact their finance or development ministry for assistance in identifying representatives from these organizations.
4. Bilateral donors with an interest in assisting the countries of the region will often be national governments with a presence in the LVC and officials within the embassy or consulate that can be engaged to discuss and develop projects. Bilateral donors have specific countries that they have identified as priorities. The Ozone Officer can find this information on the national governments aid agency websites that are provided in the Annex 2. Any of these governments that are operating in an LVC could be approached by an Ozone Officer in a NOU for discussion of the HPMP implementation and achieving climate co-benefits. Another avenue through which bilateral donors can be identified is through discussions in the margins of the Meetings of the Parties, Open-ended Working Group, Executive Committee, and Regional Networks of Ozone Officers, as well as “corridor discussions” during climate negotiations and other regional environmental meetings and conferences.

5. Internationally-recognized and reputable appliance manufacturers and their representatives that are operating in the developing country may become important players in a projects to achieve climate co-benefits, for example for replacing refrigeration equipment. The example of the efforts of the company *Dybvad Stål Industri* (DSI) in the Solomon Islands is described in box 12.⁵³ The national RAC association is an extremely important partner for the Ozone Officer in the RAC sector, and it can provide ideas and contacts for reputable RAC companies that could be approached. Additionally, an Ozone Officer can identify companies that are both active in the region and have interests in low-GWP or zero GWP technology by researching the websites of RAC appliance manufacturers. By emailing or calling a customer relations contact in a RAC company, it should be possible to begin explorations of possible collaborations.

Box 12: Private sector assists with RAC investments in Solomon Islands

The company Dybvad Stål Industri (DSI) has sold many freezers for the seafood industry in Asia. In a recent project, a freezer was installed in a fish processing plant in the Solomon Islands, freezing tuna loins. The self-contained plate freezer DSI PFP 2810 operates on ammonia. It is equipped with a refrigeration system and needs only a power connection and cooling water to operate. The end-users are mainly fish factories that are exporting some of their products to the USA and Europe. The DSI 2000 series has a high freezing rate and low power consumption and meets new strict hygienic standards. It is suitable for marine and land installation. Primary use is to freeze seafood such as fish, fish fillets, shrimps, roe, squid, etc.; vegetables such as chopped spinach, broccoli, carrots, etc.; pulp and concentrates.

STEP IV – Make a compelling proposal: Calculate the climate co-benefits of the HPMP

To convince a potential donor that its support would be an effective and appropriate use of funds, Ozone Officers should link their project proposals with the national priorities and plans such as the national development strategy, the PRSP, the CAS, or UNDAF. In addition, it is important to demonstrate any benefits (especially climate benefits) from energy efficiency gains is an important tool to obtain financial support from potential donors. If possible, get the endorsement from the appropriate line ministries. An example of how to calculate the benefits is as follows:

1. Forecast the growth rate of HCFC-22 consumption

Note: For small countries where HCFC-22 is consumed solely for servicing refrigeration and air conditioning, an increase of HCFC-22 consumption could mean increasing numbers of RAC units that will require servicing in the future.

2. Develop the “Case” for climate co-benefits

- Determine the popular model size of RAC appliances in kW (or Btu) and the average charge size in kg per unit.
 - Assume average charge for servicing in kg/year.

⁵³ UNIDO and SHECCO SPRL, *Guide 2013: Natural Solutions for Developing Countries including UNIDO Atmosphere Summary Report* (November 2013), page 50, http://www.unido.org/fileadmin/user_media_upgrade/What_we_do/Topics/Multilateral_environmental_agreement_s/GUIDE-UNIDO-natural-substances-2013-small.pdf

- Outline the HCFC Phase-out Strategy:
Describe Assumptions
 - refrigeration and air conditioning Charge Size
 - Refrigeration Recharge (Service) in Kg/unit/year
 - Useful Life in Years
- Current Regional Market of refrigeration and air conditioning:
Number of replacement units + Number of units for growth = Number of units in the regional market
- Develop Assumptions to define climate co-benefits of more energy efficient appliances:
 - Carbon Intensity Factor – in Kg CO₂/kWh
 - Baseline Energy Efficiency Rating (EER)
 - New EER
 - Cooling Capacity (for Air Conditioning) in kW
 - Operating Hours in hours/day
 - CDM No. of Days in Days/Year
 - Cost of electricity in \$ per kWh
 - If appropriate - Carbon Revenue in \$ per tCO₂
- Determine the cost and specifications for the existing stock of HCFC-based RAC equipment:
 - An example of costs for HCFC-22 residential air conditioning units

Capacity (Btu)	Capacity (kW)	Voltage	Price (USD)	EER (Btu)	EER (SI)
9,000	2.93	220	379	10	2.93
13,000	3.81	220	450	10	2.93
18,000	5.28	220	599	10	2.93
24,000	7.03	220	732	10	2.93

- Estimate the cost and specifications of the new energy efficient low-GWP RAC equipment that could be introduced:
 - An example of costs for R-410A residential air conditioning units

Capacity (Btu)	Capacity (kW)	Voltage	Price (USD)	EER (Btu)	EER (SI)
9,000	2.64	110	450	14.5	4.25
12,000	3.52	220	525	13.5	3.96
18,000	5.28	220	659	13.5	3.96
24,000	7.03	220	895	13.5	3.96

3. Ban imports/production of R-22 refrigeration and air conditioning with CDM (0% and 20% Growth) if appropriate

- Example of Benefits Calculation

- R-22 Consumption:
 - R-22 consumption for the servicing sector will be phased out within 10 years.
- Energy Savings
 - 1.5 – 5.5 million MWh in 2018
 - 450 – 1,680 MW of Electricity Generation Saved (USD 0.9 - USD 3.4 billion deferred investment)
- Additional Revenues if appropriate
 - Energy Savings -USD 0.6 - USD 1.7 billion
 - CDM Revenue If available - USD 50 - USD 138 million

4. Sensitivity Analysis

- Example of a sensitivity analysis for residential air conditioning units

Growth Rate per Annum	0%	10%	15%	20%
Energy Consumption Reduction	1.45 million MWh	2.9 million MWh	4 million MWh	5.5 million MWh
Reduced Demand for Electricity Generation Capacity	450 MW	890 MW	1,200 MW	1,670 MW
Deferred Investment for New Capacity	\$1 billion	\$1.7 billion	\$2.4 billion	\$3.4 billion
Energy Savings (7 years)	\$0.6 billion	\$1 billion	\$1.3 billion	\$1.7 billion
CDM Revenues (7 years) If this is available	\$50 million	\$84 million	\$108 million	\$138 million

STEP V – “Making the case”: Prepare yourself for discussions with potential donors

The situation faced by each Ozone Officer in preparing for discussions with potential donor partners will be unique; therefore they should consider the following suggestions in their own national and regional contexts:

1. The most important preparations will be around understanding in detail your country’s HPMP and refrigeration sector, as outlined in Step I.
2. “Do your homework” on which potential partners exist inside your own country is equally as important as knowing the technical details of what is contained in the HPMP and in the refrigeration sector. This “homework” includes having formal and informal discussions with colleagues who are national focal points for the GEF or other international agreements as well as public servants in other government agencies responsible for the CAS, PRSPs or UNDAF processes described in Section 5, and who may be willing to include the HPMP in those strategies as a priority. The Ozone Officer’s “homework” also includes identifying any other governments with embassies in the country, regional development banks or other international development agencies that might be willing to discuss partnering or co-funding –

or other financial assistance to support climate co-benefits of the HPMP. When researching the potential partners, do not forget to note any international private sector organizations or companies in the refrigeration sector that might be able to participate in a partnership.

3. It is important to try to estimate what the climate co-benefits might be in improving energy efficiency of refrigeration in your country. In many LVCs, the number of appliances may be so small that the value of the climate co-benefits may not be sufficient to interest potential partners. In that case, a regional approach, such as that which was created with the assistance of the ADB for Cook Island, Samoa, Tonga, Vanuatu and Papua New Guinea (See Box 3) may be a worthwhile line of attack to pursue.

At this point, you should be ready to engage potential national, bilateral, regional and multilateral public and private partners to seek financial support for the climate co-benefits of the HPMP. During the engagement, there will be certain issues and constraints that will add to the effort and time that an Ozone Officer will need to set aside to undertake the engagement. These may require strategic and targeted discussions with potential partners beyond the discussion of how to financially support climate co-benefits of the HPMP. It may be important to discuss support for the resources required for mobilization, time required for applications, length of time from application through to receipt of financing.⁵⁴

As with the development of any projects to implement the HPMP,⁵⁵ when developing project concepts and speaking with a potential financing institution or implementing partner about your project ideas, there are certain elements that should be kept in mind:

- Ensure additionality. “Additionality” is a term frequently used in relation to project proposals that means the measurement of an intervention (i.e., doing something), when the intervention is compared to the baseline or status quo situation (i.e., doing nothing). This term is frequently used in relation to climate change, however it applies equally to any type of projects, including ODS phase out, chemicals and energy efficiency projects.
- Transparency and good governance.⁵⁶ These key principles are familiar to most civil servants, including Ozone Officers and other professionals working under international financial mechanisms like the Multilateral Fund. Design any resource mobilization project for

⁵⁴ UNIDO, *Chiller demonstration projects: Achievements & lessons learnt*. Joint meeting of the Regional Ozone Networks for Europe & Central Asia (ECA) and South Asia (SA). Istanbul, Turkey. 26-30 April 2010; *Chiller Demonstration Projects: Achievements and Lessons Learnt. The Global Chiller Replacement Project*. Mary-Ellen Foley. Montreal Protocol Operations, The World Bank. 26-30 April 2010. Istanbul, Turkey; Viraj Vithoontien, Montreal Protocol Operations, The World Bank Group, *Strategies for HCFC Phase-out Management Plan*. Regional Workshop of Caribbean Ozone Officers. 25 March 2009.

⁵⁵ UNEP/OzL.Pro/ExCom/63/L.1 7 April 2011. Para 84 (a) (ii).

<http://www.multilateralfund.org/63/Draft%20Report%20English/1/63L1draft-8-April.doc>

⁵⁶ Good governance has 8 major characteristics. It is participatory, consensus oriented, accountable, transparent, responsive, effective and efficient, equitable and inclusive and follows the rule of law. It assures that corruption is minimized, the views of minorities are taken into account and that the voices of the most vulnerable in society are heard in decision-making. It is also responsive to the present and future needs of society.

<http://www.unescap.org/pdd/prs/ProjectActivities/Ongoing/gg/governance.asp>

- Avoid “perverse incentives.” This term, which is usually applied in the context of climate change, describes a situation where an action that is supposed to achieve one result (positive) accidentally creates a problem somewhere else (negative). It is a type of unintended consequence when the impacts and outcome of a project are not considered carefully. In the context of resource mobilization related to climate co-benefits of HPMPs, practically speaking this means that the Ozone Officer should be particularly careful during the project design stage to consider all possible outcomes (intended and unintended).
- Explore possibilities of profit-sharing, including return of funds to the Multilateral Fund. When designing a co-funding proposal, if the project includes potential profit generation (e.g. from private sector involvement), try to consider what would happen to any new funds that might be generated. The Multilateral Fund has traditionally collected any funds generated from projects that it has financially supported (notably the chiller replacement programme), and used those new resources to finance new Multilateral Fund projects (the resource mobilization projects of all Implementing Agencies are good examples of this “recycling” process). Accordingly, when designing your resource mobilization project, consider whether any funds might be generated and if so, make a plan for how they will be collected and informed to the Multilateral Fund.
- Ensure sustainability of the projects proposed. As with any good project design, the resource mobilization proposal should consider ways and means to sustain the outcome of the project after the initial funding is used. Try to identify and build such approaches into the original proposal.
- Avoidance of duplication of similar projects. This is part of the due diligence process you should follow for any project proposal. It is part of your “homework” to ensure that whatever resource mobilization proposal related to climate co-benefits of HPMPs does not duplicate any other existing project, either inside or outside of the Multilateral Fund. Make sure that what you are proposing does not duplicate activities currently funded or eligible for future funding under the Multilateral Fund (consult the Implementing Agency working with you).
- Information on transaction costs. Developing, submitting and negotiating project proposals takes resources takes expertise, time, and energy. Sometimes it takes considerable effort to do it right. It is important to keep track of your estimated “transaction costs” from the start of the project concept until the project is approved (or not approved). This information is useful to provide as feedback to both your Director/management, the organization from which you are seeking financing, and also to and even the Executive Committee. Such information could be reported under the HPMP in terms of activities/resources undertaken to seek climate co-benefits for the HCFC activities.

STEP VI - Next Steps

Finally, undertake the necessary final internal discussions within the country and with partners either in the public or private sector to establish the agreed terms and conditions of the project and financial support including management, monitoring, evaluation, reporting.

During the project development and submission process — and even during implementation — UNEP encourages Ozone Officers to share the project experience with other NOUs through

presentations and discussions at the Regional Network meetings (see box 13). Such exchanges can inform and inspire colleagues to achieve similar results.

Box 13: Lesson learned

Experience shows that Regional networking plays an important role in helping replicate the successful features of well-designed co-financing projects into future or on-going projects. During meetings and workshops, project managers and country office personnel discuss both technical and administrative issues, share experiences and best practices, and gain a sense of how the portfolio functions at a regional level.⁵⁷

— *Multilateral Fund chiller project desk study*

⁵⁷ Multilateral Fund *Desk Study on the Evaluation of Chiller Projects* (UNEP/OzL.Pro/ExCom/68/10), para 14.

Annex 1: Overview of UNEP's resource mobilization project

UNEP submitted a project proposal for "Resource mobilization to address climate co-benefits for the HCFC phase-out in LVC countries with servicing sector only" as part of its 2011 Work Programme Amendment for the consideration of the 63rd Executive Committee.⁵⁸ The original project sought to prepare a detailed study outlining specific financing options, complete five regional workshops on resource mobilisation, and prepare a pilot application for one LVC for funding for activities in HPMP not covered by the Multilateral Fund, at a budget of US\$ 250,000 plus programme support costs.

Following discussions, the Executive Committee through Decision 63/22 (a) approved a project for UNEP⁵⁹ as follows:

"a) To approve funding at the level of US \$100,000, plus agency support costs of US \$13,000 for UNEP, for a study on financing options, regional workshops on co-financing, and/or one or more pilot applications of co-financing for one or more low-volume-consuming countries with an approved HCFC phase-out management plan, to be funded as resource mobilization activities on the condition that an interim report would be provided at the 66th meeting, which would include an update on the activities so far undertaken and address the following elements:

- (i) Additionality of the projects proposed;
- (ii) Transparency and good governance, as well as covering the cash flow;
- (iii) Assurance that these projects would avoid perverse incentives for countries;
- (iv) Exploring possibilities of profit-sharing, including return of funds to the Multilateral Fund;
- (v) Ensuring sustainability of the projects proposed;
- (vi) Avoidance of duplication of similar projects;
- (vii) Information on transaction costs;

(b) To request UNEP to ensure that the regional workshops were held in the context of the network meetings under UNEP's Compliance Assistance Programme so as to ensure cost-effectiveness, and that the timing of the workshops would be such to allow the experiences of other agencies' resource mobilization activities to be incorporated;

(c) To note that the funds approved would be taken from the budget reserved for unspecified projects that had been set aside from the funds returned from the Thai chiller project; and

(d) To request UNEP to provide a final report for consideration by the Executive Committee at its 69th meeting."

Under this revised project scope and resources, and following consultations within the CAP team and with select Ozone Officers, UNEP selected the first option in the decision, i.e. the study and regional workshops, instead of developing a pilot application the former option would have a wide impact on many LVCs.

UNEP engaged an international expert in the field of resource mobilization to research and draft the study on financing options (i.e. this document), and arranged for quality review by two experts, one of whom is an Ozone Officer from an LVC. UNEP conducted the workshop component of the project over the period May 2013 to March 2014 (see Annex 2) in a way that was mutually supportive with the development of this document.

⁵⁸ UNEP/OzL.Pro/ExCom/63/19.

⁵⁹ GLO/SEV/63/TAS/308.

UNEP submitted an interim report on the project to the 66th Executive Committee meeting, which noted the report and requested UNEP to submit a more substantial report to the 68th meeting (Decision 66/15(m)). At the 68th meeting, UNEP submitted another interim report. During the discussions of the resource mobilization projects of all Implementing Agencies, the Executive Committee noted the important information on resource mobilization provided in the *Desk Study on the Evaluation of Chiller Projects*⁶⁰ and the 68th meeting report,⁶¹ and requested that UNDP, UNEP, UNIDO and the World Bank take into account the information provided the desk study, where relevant, and incorporate such information in the final reports on resource mobilization for in the context of the terms of reference set out in decisions 63/20, 63/22, 63/23 and 63/24 (Decision 68/4 (c)).

For both project components, UNEP considered the Multilateral Fund *Desk Study on the Evaluation of Chiller Projects* during the project development insofar as its recommendations apply to the LVC context, as per Executive Committee decision 68/4(c). UNEP also considered the information contained in the final reports on resource mobilization for climate co-benefits submitted by UNDP,⁶² UNIDO,⁶³ and World Bank⁶⁴ as they became available.

UNEP submitted an interim report on the project⁶⁵ to the 69th meeting, which the Executive Committee noted and then urged UNEP to provide a draft of the study in the form of an information paper to the Executive Committee's 70th meeting; to submit the final study to the 71st meeting, taking into account guidance provided by the Executive Committee at the 70th meeting; and to complete the regional workshops on co-financing by December 2013 with a view to providing a report on their conclusions to the first meeting in 2014 (Decision 69/4 (c)).

UNEP submitted to the 70th meeting of the Executive Committee (1-5 July 2013) the *Draft Annotated Outline of the Study on Financing Options to Address Climate Co-Benefits for HCFC Phase-out in LVCs with Servicing Sector Only*.⁶⁶ In that detailed submission, UNEP noted that the project was a work in progress and it welcomed any guidance or inputs (e.g. examples of successful resource mobilisation in LVCs) from Executive Committee members or others to consider during the finalization of the document. During the Committee's deliberations, a member noted the relation between the *Discussion Paper on Minimizing Adverse Climate Impact of HCFC Phase-Out in the Refrigeration Servicing Sector*⁶⁷ and the study being prepared by UNEP. He encouraged the Secretariat to conduct further analysis of the issue and to engage in further discussion with UNEP and the other implementing agencies in order to exchange ideas and strategies to address the servicing sector in the most effective way possible to achieve compliance

⁶⁰ UNEP/OzL.Pro/ExCom/68/10.

⁶¹ UNEP/OzL.Pro/ExCom/68/53, paragraphs 48 to 54.

⁶² UNEP/OzL.Pro/ExCom/71/6/Add.1.

⁶³ UNEP/OzL.Pro/ExCom/69/5.

⁶⁴ UNEP/OzL.Pro/ExCom/71/6/Add.1.

⁶⁵ UNEP/OzL.Pro/ExCom/69/5.

⁶⁶ UNEP/OzL.Pro/ExCom/70/Inf.3.

⁶⁷ UNEP/OzL.Pro/ExCom/70/53.

and minimize adverse climate impact.⁶⁸ The Executive Committee agreed to defer consideration of the draft annotated outline of the study.⁶⁹

As the consideration of the outline was not continued during the 71st or 72nd Executive Committee meetings, UNEP proceeded with the finalization of the document on the basis of the previously-submitted outline, the comment received during the 70th meeting, and inputs from Ozone Officers and others received during the four resource mobilisation workshops. UNEP submitted the final version of the study to the Executive Committee for consideration at its 73rd Meeting.

⁶⁸ UNEP/OzL.Pro/ExCom/70/59, para 117.

⁶⁹ UNEP/OzL.Pro/ExCom/70/59, para 149.

Annex 2: Summary of the regional resource mobilization workshops

As part of the project on “Resource mobilization to address climate co-benefits for the HCFC phase-out in LVC countries with servicing sector only,”⁷⁰ UNEP organized four regional workshops on co-financing with the objective of bringing stakeholders and representatives of the various appropriate funding mechanisms together to build the capacity of the participating Ozone Officers from Article 5 countries on accessing these financial mechanisms. UNEP also used the workshops as an opportunity for Ozone Officers from LVCs to share their experiences/inputs and voice their needs in relation to the guidance document on financing options that UNEP was preparing in parallel to the workshops. Thus, the workshops and the document were integrated throughout the project duration.

In accordance with Decision 63/22 (b), UNEP ensured that the regional workshops were held in the context of the 2013/2014 meetings of the Regional Networks of Ozone Officers under UNEP’s Compliance Assistance Programme so as to ensure cost-effectiveness, and that the timing of the workshops would be such to allow the experiences of other agencies’ resource mobilization activities to be incorporated. Accordingly, the four workshops on “Opportunities for resource mobilization and climate benefits related to refrigeration servicing sector” were held as follows:⁷¹

- Asia-Pacific: The workshop on was organized on 8 May 2013 in Gold Coast, Australia, back to back with the Joint Meeting of the South Asia (SA), South East Asia and the Pacific (SEAP) and the Pacific Islands Countries (PIC) Regional Networks of Ozone Officers.
- Europe and Central Asia: The workshop on was organized on 21 May 2013 in Ohrid, Macedonia FYR, back to back with the Annual Meeting of the ECA Network of Ozone Officers.
- Latin America and the Caribbean: The workshop on was organized in Kingston, Jamaica on 30 September 2013 back to back with the Meeting of the Latin American and Caribbean Networks of Ozone Officers.
- Africa: The workshop on was organized in Addis Ababa, Ethiopia on 28 March 2014, back to back with the Joint Meeting of French-Speaking and English-Speaking Africa.

The workshops were one half day or one day in length, depending on the preference and schedule of the respective Network meetings. Model agendas were prepared to ensure some level of standardization across the Networks, with the provision that each region could adapt the agendas as per its local requirements. The workshops were designed to be inter-active to encourage discussion and brainstorming on the subject, and included both presentations, discussion panels, and roundtable exchanges.

The workshop participants were all of the National Ozone Officers who participated in the associated Regional Network meetings. UNEP also invited the following organizations as speakers share their resource mobilization experiences: Multilateral Fund Secretariat, Ozone Secretariat, Implementing Agencies, bilateral agencies/non-Article 5 countries, and selected Ozone Officers with relevant co-financing experience. In all of the workshops, UNDP, UNIDO and the World Bank conveyed the results to-date of their own resource mobilization projects separately-approved under the Multilateral Fund, shared their

⁷⁰ See Annex 1.

⁷¹ UNEP did not organize a resource mobilization in West Asia since the region does not have any low-volume consuming country, and it is therefore outside of the scope of the approved project. However, discussions on resource mobilization for the climate co-benefit of the HCFC phase out have taken place during the region’s Network and thematic meetings, to a certain extent.

extensive experiences with resource mobilization with respect to both LVCs and non-LVCs, and participated actively in the ensuing roundtable discussions.

UNEP retained external experts familiar with resource mobilization to moderate the workshops in a neutral and unbiased manner, and to make the framework presentations. During some of the workshops, other organisations also delivered presentations or moderated sessions during some of the workshops, such as the Asia-Pacific Technical College (APTC), Colombia, Croatia, Macedonia (Former Yugoslav Republic of), Saint Lucia, United States and private sector companies. In some of the workshops, other UNEP staff members working on related issues outside of Montreal Protocol (i.e. climate change and financing) also participated as speakers or moderators.

The agendas of the four workshops covered a range of topics, such as:

- Overview of financing options for LVC countries with servicing sector only.
- Resource mobilization to address climate co-benefits for HCFC phase-out in the context of Multilateral Fund decisions and policies.
- Experiences of the implementing agencies and bilateral agencies.
- Clean Development Mechanism.
- Global Environment Facility.
- Case studies or experiences (Caribbean, Colombia, Gambia, Ghana, Macedonia FYR, Croatia, Vietnam, etc.)
- European financing instrument for pre-accession countries.
- NAMAs in the refrigeration, air conditioning and foam blowing sector.
- Prospects for regional development banks to contribute to resource mobilization related to the HCFC phase out in Article 5 countries.

The Africa workshop provided the Implementing Agencies with a good opportunity to share the results of their resource mobilization projects, particularly the experiences with Gambia, Ghana and Vietnam projects co-financed with the GEF. The workshop also discussed the fundamentals of resource mobilization including development and submission of grant proposals, mobilization of national resources, and fundraising principles. The Asia-Pacific workshop provided a good opportunity for Australia, Italy and the United States to share their experience in offsetting costs in their own domestic HCFC phase-out program. A few countries like Fiji, Cook Island, Bangladesh noted efforts in attracting financing for the climate co-benefits. The Europe and Central Asia workshop highlighted the keen interest by Ozone Officers in better understanding the resource mobilization opportunities with Macedonia and Croatia mentioning the creation of funding opportunities to support their Montreal Protocol programs. The Latin America and the Caribbean meeting clarified that there is a need to have a system in place that provides the most up to date information on technologies in terms of performance and alternative gases. There was also an interesting discussion on the need for a few pilot countries to demonstrate how this financing could take place.

Some of the common messages received from Ozone Officers during the workshops include:

- The subject of resource mobilization and climate co-benefits is new to virtually all Ozone Officers and is not traditionally an area in which they have worked. Ozone Officers need assistance to develop their own expertise in project financing and designing project proposals. They also need assistance to further develop their capacity for making the linkages between the HCFC phase out, energy efficiency and climate co-benefits.

- Due to the shortage of human resources in NOUs, as well as lack of skills and knowledge in this area, resource mobilization for the climate benefits of the HCFC phase out needs more efforts. National Ozone officers highlighted the need for continued assistance from all agencies on this subject.
- Resource mobilization does not necessarily mean just funds, but can also mean human resources such as training and knowledge sharing.
- Ozone Officers expressed the need for project preparation funds that focus on the climate co-benefits.
- Ozone Officers should explore as a priority the opportunities for internal (i.e. domestic) resource mobilization. This can include the use of economic instruments, other government programmes and private sector resources.

Annex 3: Useful contacts and background information

Final reports of Implementing Agency resource mobilization projects

- UNDP, *Final report on resource mobilization for climate co-benefits* (UNEP/OzL.Pro/ExCom/71/6/Add.1), <http://www.multilateralfund.org/71/English/1/7106a1.pdf>
- UNIDO, *Final report on development of pilot proposals for possible co-financing for HCFC activities, to be funded as resource mobilization activities* (UNEP/OzL.Pro/ExCom/69/5) <http://www.multilateralfund.org/69/English/1/6905.pdf>
- World Bank, *Final report on resource mobilization for HCFC phase-out and climate mitigation co-benefits* (UNEP/OzL.Pro/ExCom/71/6/Add.1), <http://www.multilateralfund.org/71/English/1/7106a1.pdf>

Multilateral Fund documents

- Multilateral Fund Senior Monitoring and Evaluation Officer, *Desk Study on the Evaluation of Chiller Projects* (UNEP/OzL.Pro/ExCom/68/10), <http://www.multilateralfund.org/68/English/1/6810.pdf>
- Multilateral Fund Secretariat, *Minimizing Adverse Climate Impact of HCFC Phase-out in the Refrigeration Servicing Sector* (UNEP/OzL.Pro/ExCom/72/42), <http://www.multilateralfund.org/72/English/1/7242.pdf>

GEF Focal Points

GEF Focal Points play a critical coordination role regarding GEF matters at country level as well as serving as the liaison with the GEF Secretariat and Implementing Agencies while representing their constituencies on the GEF Council. The GEF Political Focal Points and Operational Focal Points have different functions, although the exact specifications of the two designations may vary from country to country. All GEF member countries have Political Focal Points, while only recipient member countries eligible for GEF project assistance have Operational Focal Points. *GEF Political Focal Points* are concerned primarily with issues related to GEF governance including policies and decisions, as well as relations between member countries and the GEF Council and Assembly. *GEF Operational Focal Points* are concerned with the operational aspects of GEF activities, such as endorsing project proposals to affirm that they are consistent with national plans and priorities and facilitating GEF coordination, integration, and consultation at country level. The list of focal points is found at http://www.thegef.org/gef/focal_points_list

Climate-related programs

- Clean Development Mechanism (CDM), <http://cdm.unfccc.int/>
- Climate and Clean Air Coalition (www.unep.org/ccac/).
- Sustainable Energy for All, <http://www.sustainableenergyforall.org/>
- The World Bank, <http://www.worldbank.org/en/topic/climatechange/overview>
 - Climate Investment Funds (CIFs), <https://www.climateinvestmentfunds.org/cif/>

- Climate Finance and Carbon Finance Unit, <http://www.worldbank.org/en/topic/climatefinance>
- Climate Change Knowledge Portal, <http://sdwebx.worldbank.org/climateportal/index.cfm>
- Climate Finance Options Platform, <http://www.climatefinanceoptions.org/cfo/index.php>

Regional Development Banks

- The Asian Development Bank (ADB), <http://www.adb.org/>
- Inter-American Development Bank (IADB), www.iadb.org/
- Caribbean Development Bank (CDB), www.caribank.org/
- African Development Bank (AfDB), <http://www.afdb.org/en/>
- Climate Investments Funds (CIF), <http://www.afdb.org/en/topics-and-sectors/initiatives-partnerships/climate-investment-funds-cif/>
- the Global Environment Facility (GEF), <http://www.afdb.org/en/topics-and-sectors/initiatives-partnerships/global-environment-facility-gef/>
- Sustainable Energy Fund for Africa (SEFA), <http://www.afdb.org/en/topics-and-sectors/initiatives-partnerships/sustainable-energy-fund-for-africa/>
- African Carbon Support Programme (ACSP), <http://www.afdb.org/en/topics-and-sectors/initiatives-partnerships/african-carbon-support-program/>
- European Bank for Reconstruction and Development (EBRD), <http://www.ebrd.com>

Funding Organisations of National Governments

- Australia: Australian AID (AUSAID), <http://www.usaid.gov.au/Pages/home.aspx>
- Austria: Austrian Development Agency, <http://www.entwicklung.at/en/>
- Belgium: Belgian Development Cooperation (DGDC), http://diplomatie.belgium.be/en/policy/development_cooperation/
- Belgium: Belgian Technical Cooperation (BTC), <http://www.btcctb.org/>
- Canada: Canadian International Development Agency (CIDA), <http://www.acdi-cida.gc.ca/acdi-cida/acdi-cida.nsf/eng/home>
- Denmark: Danish International Development Assistance (DANIDA), <http://um.dk/en/danida-en/>
- Denmark: Danish Ministry of Foreign Affairs (MOFA), <http://um.dk/en>
- European Commission: DG Development (DG DEV) also EU Enlargement-related funds, <http://ec.europa.eu/trade/policy/countries-and-regions/regions/africa-caribbean-pacific/>
- France: Ministère des Affaires étrangères et européennes (MAEE), <http://www.diplomatie.gouv.fr/en/>
- France: Direction générale de la Coopération internationale et du Développement (DGCID), <http://www.irc.nl/page/6890>
- Finland: Ministry of Foreign Affairs (MoFA), <http://formin.finland.fi/public/default.aspx?culture=en-US&contentlan=2>
- Germany: Deutsche Gesellschaft für Internationale Zusammenarbeit GmbH (GIZ), <http://www.giz.de/en/>
- Germany: Bundesministerium für Wirtschaftliche Zusammenarbeit und Entwicklung (BMZ), <http://www.bmz.de/en/index.html>
- Ireland: Irish Aid, <http://www.dci.gov.ie/>
- Italy: Cooperazione Italiana allo Sviluppo, <http://www.cooperazioneallosviluppo.esteri.it/pdgcgs/>

- Japan: International Cooperation Agency (JICA), <http://www.jica.go.jp/english/>
- Japan: Official Development Assistance (ODA), Ministry of Foreign Affairs (MoFA), <http://www.mofa.go.jp/policy/oda>
- Japan: Bank for International Cooperation (JBIC), <http://www.jbic.go.jp/en/>
- Luxembourg: Ministère des Affaires Étrangères, <http://www.mae.lu/en>
- Luxembourg: Agence Luxembourgeoise pour La Coopération Luxembourgeoise au Développement, <http://luxdev.lu/en>
- Netherlands: Ministry of Foreign Affairs (MoFA), <http://www.government.nl/ministries/bz>
- New Zealand: New Zealand Aid (NZAid), <http://www.aid.govt.nz/>
- Norway: Ministry of Foreign Affairs, <http://www.regjeringen.no/en/dep/ud.html?id=833>
- Norway: Norwegian Agency for Development and Cooperation (NORAD), <http://www.norad.no/en/front-page;jsessionid=0D0F0A6AF492616F55F671C9D9D94F11>
- Portugal: Instituto Português de Apoio Ao Desenvolvimento (IPAD), <http://ns1.ipad.mne.gov.pt/>
- Spain: Agencia Española de Cooperación Internacional (AECI), <http://www.aecid.es/en/aecid/>
- Sweden: Swedish International Development Cooperation Agency (SIDA), <http://www.sida.se/english/>
- Switzerland: Swiss Agency for Development and Cooperation (SDC), <http://www.sdc.admin.ch/en/Home>
- Switzerland: State Secretariat of Foreign Affairs (SECO), <http://www.seco.admin.ch/index.html?lang=en>
- United Kingdom: Department for International Development (DFID), <https://www.gov.uk/government/organisations/department-for-international-development>
- United State: United States Agency for International Development (USAID), <http://www.usaid.gov/>
- United States: Millennium Challenge Corporation (MCC), <http://www.mcc.gov/>

Clean Development Mechanism approved methodologies

- AMS-II.O.: Dissemination of energy efficient household appliances --- Version 1.0, <http://cdm.unfccc.int/methodologies/DB/OE502PQ0NA9ETZ5IB6HL0ZT2BBKZ35>
- AMS-III.X.: Energy Efficiency and HFC-134a Recovery in Residential Refrigerators --- Version 2.0, <http://cdm.unfccc.int/methodologies/DB/983EQY2RSIYT5Q1KN4FIWHU2FL3MHP>
- AMS-III.AB.: Avoidance of HFC emissions in Standalone Commercial Refrigeration Cabinets --- Version 1.0, <http://cdm.unfccc.int/methodologies/DB/GZRYKNFXDOF06WWJ3DG87GU8I4H1EZ>
- AM0060: Power saving through replacement by energy efficient chillers --- Version 1.1, <http://cdm.unfccc.int/methodologies/DB/YK8TH8WJAQDX52TC32G9C627X17P38>
- AM0070: Manufacturing of energy efficient domestic refrigerators --- Version 3.1.0, <http://cdm.unfccc.int/methodologies/DB/R66P8LFQUC3009F2GX9Z9CTMN9B8W5>
- AM0071: Manufacturing and servicing of domestic refrigeration appliances using a low GWP refrigerant --- Version 2.0, <http://cdm.unfccc.int/methodologies/DB/ZWFK8F3U3CSHU75ST3VCPZMVN5VG0>

Annex 4: Multilateral Fund eligible incremental costs of HCFC phase-out projects⁷²

Decision 60/43

Eligible incremental costs of HCFC phase-out projects

(f) To apply the following principles in regard to eligible incremental costs of HCFC phase-out projects for the first stage of HPMP implementation to achieve the 2013 and 2015 HCFC phase-out compliance targets, subject to a review in 2013:

(i) When preparing HCFC phase-out projects in the foam, refrigeration and air-conditioning sectors, bilateral and implementing agencies shall use the technical information contained in document UNEP/OzL.Pro/ExCom/55/47 as a guide;

(ii) The current cost-effectiveness threshold values used for CFC phase-out projects in paragraph 32 of the final report of the 16th Meeting of the Executive Committee (document UNEP/OzL.Pro/ExCom/16/20), to be measured in metric kilogrammes, shall be used as guidelines during the development and implementation of the first stage of HPMPs;

(iii) That countries will have the flexibility to allocate the approved funding from incremental operating costs to incremental capital costs and to allocate up to 20 per cent of the approved funding for incremental capital costs to incremental operating costs, as long as the use of the flexibility does not change the intent of the project. Any reallocation should be reported to the Executive Committee;

(iv) Funding of up to a maximum of 25 per cent above the cost effectiveness threshold will be provided for projects when needed for the introduction of low global warming potential (GWP) alternatives;

HCFC phase-out in the refrigeration and air-conditioning manufacturing sector

(viii) Incremental operating costs for projects in the air conditioning sub-sector will be considered at USD 6.30/metric kg of HCFC consumption to be phased out at the manufacturing enterprise;

(ix) Incremental operating costs for projects in the commercial refrigeration sub-sector will be considered at USD 3.80/metric kg of HCFC consumption to be phased out at the manufacturing enterprise;

(x) Consistent with decision 31/45 of the Executive Committee, incremental operating costs will not be considered for enterprises categorized under the refrigeration equipment assembly, installation and charging sub-sector;

HCFC phase-out in the refrigeration servicing sector

(xi) Article 5 countries that have total HCFC consumption of up to 360 metric tonnes must include in their HPMP, as a minimum:

a. A commitment to meeting, without further requests for funding, at least the freeze in 2013 and the 10 per cent reduction step in 2015, and if the country so decides, the 35 per cent reduction step in 2020. This shall include a commitment by the country to restrict imports of HCFC-based equipment if necessary to achieve compliance with the reduction steps to support relevant phase-out activities;

b. Mandatory reporting, by the time funding tranches for the HPMP are requested, on the implementation of activities undertaken in the refrigeration servicing sector and in the

⁷²Excerpt from UNEP/OzL.Pro/ExCom/60/54

www.multilateralfund.org/sites/60/Document%20Library2/1/6054.pdf

manufacturing sector when applicable, in the previous year, as well as a thorough and comprehensive annual work plan for the implementation of the following activities associated with the next tranche;

c. A description of the roles and responsibilities of major stakeholders, as well as the lead implementing agency and the cooperating agencies, where applicable;

(xii) Article 5 countries that have total HCFC consumption of up to 360 metric tonnes will be provided funding consistent with the level of consumption in the refrigeration servicing sector as shown in the table below, on the understanding that project proposals will still need to demonstrate that the funding level is necessary to achieve the 2013 and 2015 phase-out targets, and if the country so decides, the 2020 phase-out targets:

Consumption (metric tonnes)*	Funding up to 2015 (US\$)	Funding up to 2020 (US\$)
>0 <15	51,700	164,500
15 <40	66,000	210,000
40 <80	88,000	280,000
80 <120	99,000	315,000
120 <160	104,500	332,500
160 <200	110,000	350,000
200 <320	176,000	560,000
320 <360	198,000	630,000

(*) Level of baseline HCFC consumption in the refrigeration servicing sector

(xiii) Article 5 countries that have total HCFC consumption of up to 360 metric tonnes and that receive funding consistent with the above table, will have flexibility in utilizing the resources available to address specific needs that might arise during project implementation to facilitate the smoothest possible phase-out of HCFCs;

(xiv) Article 5 countries that have total HCFC consumption of up to 360 metric tonnes, used in both the manufacturing and refrigeration servicing sectors, could submit HCFC phase-out investment projects in accordance with prevailing policies and decisions of the Multilateral Fund, in addition to funding for addressing HCFC consumption in the servicing sector;

(xv) Article 5 countries that have total HCFC consumption above 360 metric tonnes should first address consumption in the manufacturing sector to meet the reduction steps in 2013 and 2015. However, if such countries clearly demonstrate that they require assistance in the refrigeration servicing sector to comply with these targets, funding for these activities, such as training, will be calculated at US\$4.50/metric kg, which will be deducted from their starting point for aggregate reductions in HCFC consumption.